

SuperTrak GEN3™

Component Data Sheets

Rev. 12, April 2023



The Foundation of World Leading Automation



This page is intentionally blank.

NOTICES

COPYRIGHT AND TRADEMARKS

© SuperTrak CONVEYANCE All rights reserved.

ATS™ and, the ATS™ logo, SuperTrak™, TrakMaster™ and other names and logos related to companies, products and services of ATS Automation Tooling Systems Inc. (ATS) and its affiliates are trademarks or service marks of ATS and its affiliates.

Windows® is a registered trademark of Microsoft Corporation, GOO GONE® is a registered trademark of Weiman Products, LLC. Other third-party company and product names mentioned herein may be trademarks of their respective companies.

No license or other right in any trademark, service mark or other intellectual property is granted in this document.

REFERENCES

References in this document to products or services of third parties and links to third-party websites or information are provided solely as a convenience to you and do not in any way constitute or imply ATS's endorsement, sponsorship, or recommendation of the third party, information, product, or service. ATS is not responsible for the content of any third-party documents or websites and does not make any representation regarding the content or accuracy of such materials. If you decide to use any such third-party materials, or third-party products or services, you do so entirely at your own risk.

GRAPHICS

All drawings, illustrations, and photographs included in this document are provided to expand and enhance the text. These graphics are representations only and are not necessarily drawn to scale. For accurate drawings, see the *Mechanical Drawing Package* and *Electrical*

This page is intentionally blank.

Table of Contents

Notes	5
Data Sheet Summary Table	5
Frame of Reference	7
Shuttle Data Sheet	9
Typical Shuttle Wheel Lifespan	11
Wheel Nominal Dimensions	11
Shuttle Linear Acceleration vs. Payload	15
Shuttle Maximum Velocity vs. Payload on a Curved Section	15
Shuttle Magnet Recommendations	16
Positional Error at Constant Velocity	17
Shuttle Magnetic Field Strength Measurement Locations	18
2-Magnet Shuttle Magnetic Measurement Values	19
3-Magnet Shuttle Magnetic Measurement Values	20
Straight Section with FME Data Sheet	21
Straight Section with RME Data Sheet	25
180 Deg. Section (500 mm) with Standard-Height Stands Data Sheet	29
180 Deg. Section (500 mm) with Low-Profile Stands Data Sheet	33
180 Deg. Section (800 mm) Data Sheet	37
90 Deg. Section Data Sheet	41
Control Panel Data Sheet	45
Power Supply Data Sheet	49
IR Reader Components (Optional) Data Sheet	53
Shuttle Setup Tools (Optional) Data Sheet	55
Shuttle Removal Tool (Optional) Data Sheet	57
SuperTrak GEN3 Frames Data Sheet	59
Additional Components for Over-Under Configurations— Data Sheet	65
Interconnect Kit (Straight Section to Straight Section) Data Sheet	67
Interconnect (SuperTrak Control Panel to Curved Section) Data Sheet	69
Gateway Board (ACB3040-C01) Data Sheet	71
Coil Driver Board (ACB3000-E01) Data Sheet	73

This page is intentionally blank.

Notes

This document provides information about SuperTrak GEN3™ components. Information found here is for general reference and may be updated without notice. Be sure you are using the most current version of this document by going to <https://supertrakconveyance.com/customer-portal/>. More information about the SuperTrak Conveyance Platform can be found in the Operation and Maintenance Manual which is also available through the link referenced above.

A gray vertical line segment in the left margin of a page indicates a section where text or a graphic has been added or updated since the prior revision of this document.

Data Sheet Summary Table

The following table summarizes the SuperTrak GEN3 components. Use the cross-references to located the data sheets for each component.

Component	Size	Option 1	Option 2	Data Sheet
Straight section ^a	1000 mm (39.37 in.) length ^a	No stands	Front-mounted electronics (FME) ^a	See Straight Section with FME Data Sheet on page 19.
		Standard-height stands ^a 345 mm (13.58 in.)		
		Low-profile stands 158 mm (6.23 in.)	Rear-mounted electronics (RME)	See Straight Section with RME Data Sheet on page 23.
90 deg. section	600 mm radius	Standard-height stands ^a 345 mm (13.58 in.)		See 90 Deg. Section Data Sheet on page 39.
180 deg. section ^a	500 mm diameter ^a (narrow)	Standard-height stands ^a 345 mm (13.58 in.)		See 180 Deg. Section (500 mm) with Standard-Height Stands Data Sheet on page 27.
		Low-profile stands 158 mm (6.23 in.)		See 180 Deg. Section (500 mm) with Low-Profile Stands Data Sheet on page 31.
	800 mm diameter (wide)	Standard-height stands ^a 345 mm (13.58 in.)		See 180 Deg. Section (800 mm) Data Sheet on page 35.

Component	Size	Option 1	Option 2	Data Sheet
Shuttle	152 mm (5.98 in.) width	2 magnets ^a		See Frame of Reference on page 5.
		3 magnets ^b		
Shuttle setup tools				See Shuttle Setup Tools (Optional) Data Sheet on page 53.
Shuttle removal tool				See Shuttle Removal Tool (Optional) Data Sheet on page 55.
Control panel				See 180 Deg. Section (500 mm) with Low-Profile Stands Data Sheet on page 31.
Power supply				See Power Supply Data Sheet on page 47.
IR reader				See IR Reader Components (Optional) Data Sheet on page 51.
SuperTrak GEN3 frame				See SuperTrak GEN3 Frames Data Sheet on page 57.
Over-Under Components				See Additional Components for Over-Under Configurations—Data Sheet on page 63.
Interconnect Kit		Straight section to straight section		See Interconnect Kit (Straight Section to Straight Section) Data Sheet on page 65.
		Control panel to curved section		See Interconnect (SuperTrak Control Panel to Curved Section) Data Sheet on page 67.
Gateway Board				See Gateway Board (ACB3040-C01) Data Sheet on page 69.
Coil Driver Board				See Coil Driver Board (ACB3000-E01) Data Sheet on page 71.

a. Denotes the standard deliverable.

b. The shuttle pitch must be >200 mm. See the product specifications for additional information.

Frame of Reference

This document describes tooling movement using the following frame of reference:

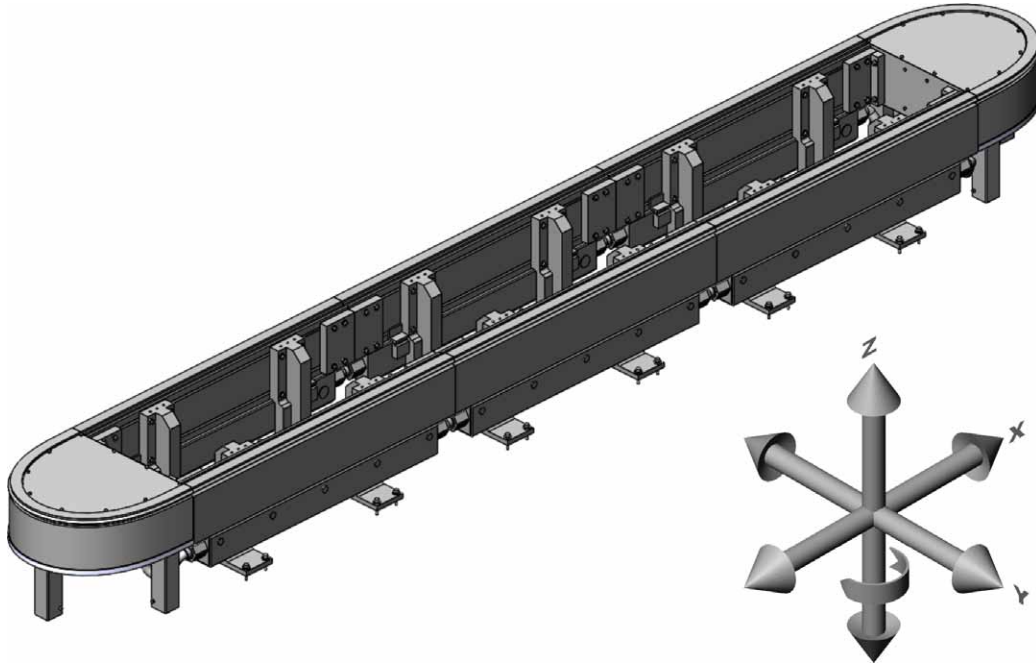

This page is intentionally blank.

Shuttle Data Sheet

The shuttle provides low friction transport with precise product positioning.

Features

- Variable load is centered by the v-wheels.
- Available in four (4) options:
 - 2-magnet shuttle with an IR tag.
 - 2-magnet shuttle without an IR tag.
 - 3-magnet shuttle with an IR tag.
 - 3-magnet shuttle without an IR tag.

See [Shuttle Magnet Recommendations](#) on page 14 for magnet selection guidance.

- Includes:
 - A keeper plate assembly that, when installed, shields the magnetic field of the magnets when the shuttle is not installed on the SuperTrak conveyance platform.
 - Holes and recesses for mounting a custom shuttle shelf.
- Requires minimal maintenance (felt lubrication, monthly inspection, and cleaning).

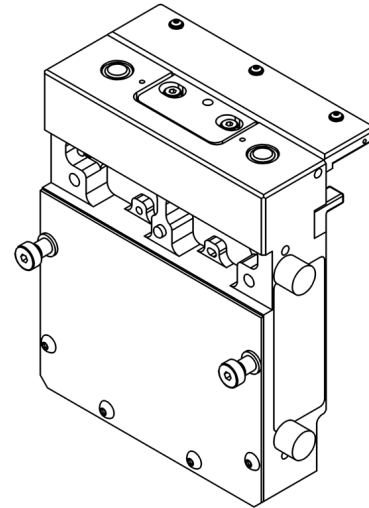

Part Numbers

Part	Part Number
2-Magnet shuttle with IR tag	25193340
2-Magnet shuttle without IR tag	25193342
3-Magnet shuttle with IR tag	25193341
3-Magnet shuttle without IR tag	25193343
IR tag (accessory)	SP-1061122

Dimensions

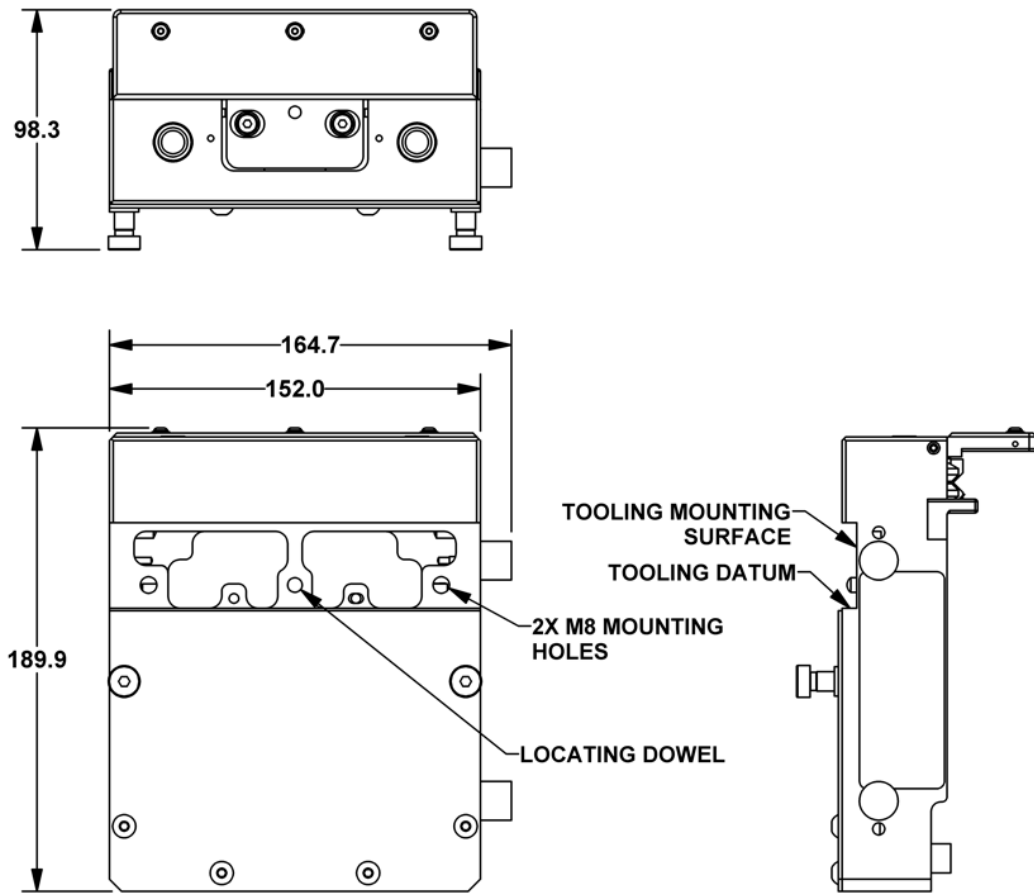

Dimensions for reference only. See SuperTrak Design Package for detailed drawings.

Typical Shuttle Wheel Lifespan

Shuttle Wheel	Distance ^a	Velocity	Rating
Upper v-wheels with rail lubrication	50,000 km (31,068 mi)	Up to 4 m/sec (13.1 ft/sec)	<0.050 mm (<0.0019 in.) wear from radius See Flat Wheel Nominal Dimensions on page 9, and V-Wheel Nominal Dimensions on page 9 for additional information.
Lower flat wheels	25,000 km (15,534 mi)		

a. Assumes correct alignment. Lifespan improves when the system is correctly aligned and installed in a clean environment.

Flat Wheel Nominal Dimensions

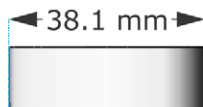

V-Wheel Nominal Dimensions

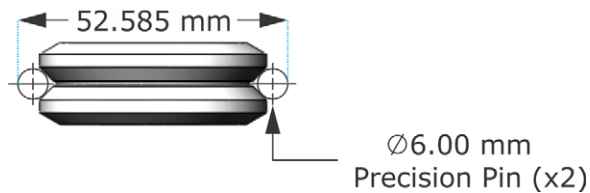

Technical Specifications

Specification	Applicable For	Value	
		2-Magnet Assembly	3-Magnet Assembly
Input power (for planning purposes) ^a	Shuttles	275W	
Accelerating force of motor (max.) ^b	Straight section	120 N (26.97 lbf)	160 N (35.96 lbf)
	180 deg. section 500 mm (19.68 in.)	48 N (10.79 lbf)	60 N (13.48 lbf)
	90 deg. section & 180 deg. section 800 mm (31.49 in.)	67 N (15.06 lbf)	84 N (18.88 lbf)

Specification	Applicable For	Value	
		2-Magnet Assembly	3-Magnet Assembly
Acceleration (max.) ^b	1 kg (2.20lb) payload	40 m/s ² (131.2 ft./s ²) See Shuttle Linear Acceleration vs. Payload on page 13.	
	10 kg (22.05 lb) payload	10 m/s ² (32.8 ft./s ²) See Shuttle Linear Acceleration vs. Payload on page 13.	
Magnetic field strength	Shuttles ^c	2.5 to 268.0 Gs See 2-Magnet Shuttle Magnetic Measurement Values on page 17, and Shuttle Magnet Recommendations on page 14	3.0 to 1400.0 Gs See 3-Magnet Shuttle Magnetic Measurement Values on page 18, and Shuttle Magnet Recommendations on page 14.
Magnetic force	Straight section	860 N (193.34 lbf)	1290 N (290.00 lbf)
	180 deg. section 500 mm (19.68 in.)	430 N (96.67 lbf)	645 N (145.00 lbf)
	90 deg. & 180 deg. section 800 mm (31.49 in.)	590 N (132.64 lbf)	775 N (174.23.00 lbf)
Material	Shuttles	<ul style="list-style-type: none"> • Cover - thermoplastic film Lubricating • Lubrication felt - SAE F1 • Magnets - neodymium • Guide roller - polyoxymethylene (POM) • Bumper - neoprene rubber (CR) • Keeper plate - polycarbonate (PC) and steel 	
Maximum unsupported process torque perpendicular to shuttle motion ^d	Straight sections	30 N-m (22.13 ft.-lbf)	50 N-m (36.88 ft.-lbf)
	180 deg. section 500 mm (19.68 in.)	20 N-m (14.75 ft.-lbf)	25 N-m (18.44 ft.-lbf)
	90 deg. section & 180 deg. section 800 mm (31.49 in.)	25 N-m (18.44 ft.-lbf)	32 N-m (23.60 ft.-lbf)
Maximum application force applied to a single shuttle wheel in any direction	Shuttles	150 N (33.7 lbf)	

Specification	Applicable For	Value	
		2-Magnet Assembly	3-Magnet Assembly
Minimum pitch from center-to-center of two (2) shuttles (as measured along the flat rail)	Straight section (with bumpers)	167 mm (6.57 in)	200 mm (7.87 in)
	Straight section (without bumpers)	154 mm (6.06 in.)	200 mm (7.87 in.)
	180 deg (500 mm) section	175 mm (6.89 in.)	200 mm (7.87 in.)
	180 deg (800 mm) section	163 mm (6.42 in.)	200 mm (7.87 in.)
	90 deg. section	163 mm (6.42 in.)	200 mm (7.87 in.)
Payload ^e	Shuttles	See Shuttle Linear Acceleration vs. Payload on page 13, Shuttle Linear Acceleration vs. Payload on page 13, and Shuttle Magnet Recommendations on page 14.	
Repeatability ^f	Straight section (X-axis)	±0.01 mm (±0.00039 in.)	
	Straight section (Y-axis)	±0.015 mm (±0.00059 in.)	
	Straight section (Z-axis)	±0.025 mm (±0.00098 in.)	
	Curved sections (X, Y, and Z-axis)	±0.025 mm (±0.00098 in.)	
Speed (max.) ^g	Straight section	4 m/s (13.1 ft./s)	
	Curved section	4 m/s (13.1 ft./s)	
Weight (without keeper plate)	Shuttles	2.02 kg (4.45 lbs)	2.4 kg (5.29 lbs)
Weight (with keeper plate)	Shuttles	2.2 kg (4.85 lbs)	2.7 kg (5.95 lbs)

- a. Validation of power consumption to be done with a TrakMaster simulation.
- b.Values depend on the application.
- c.There are no motor-related magnetic fields around the sections when shuttles are not present.
- d. Includes process force, product fixture mass, and product mass. The rotation point for the moment load is calculated from the flat wheels for downward forces (left image), and from the v-wheels for upward forces (right image).

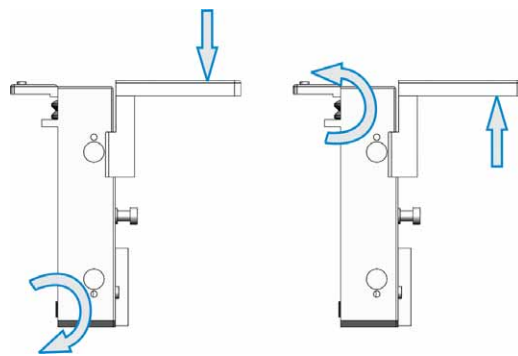

e. Payload is the mass of the tooling and parts added to the base shuttle and does not include the weight of the base shuttle itself. The base shuttle weight without the shelf is 2kg for the 2 magnet shuttle OR 2.4kg for the 3 magnet shuttle.

For example if you weighed the whole shuttle and it came to 5kg, considering the formula below:

$$(\text{Payload Weight}) = (\text{Total Weight}) - (\text{Shuttle Weight})$$

The payload for a 2 magnet shuttle would be 3kg = 5kg - 2kg

The payload for a 3 magnet shuttle would be 2.6kg = 5kg - 2.4kg

f. Values listed in table are for a single shuttle, not shuttle-to-shuttle. Repeatability axes for straight sections are defined in the graphic at right.

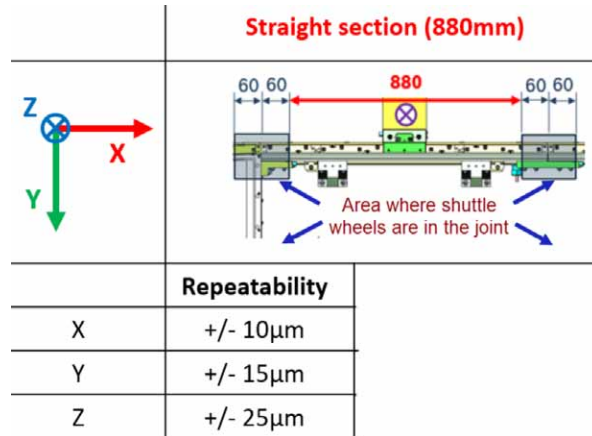

g. Speed around curved sections is mass dependent. See [Shuttle Maximum Velocity vs. Payload on a Curved Section](#) on page 13.

Shuttle Linear Acceleration vs. Payload

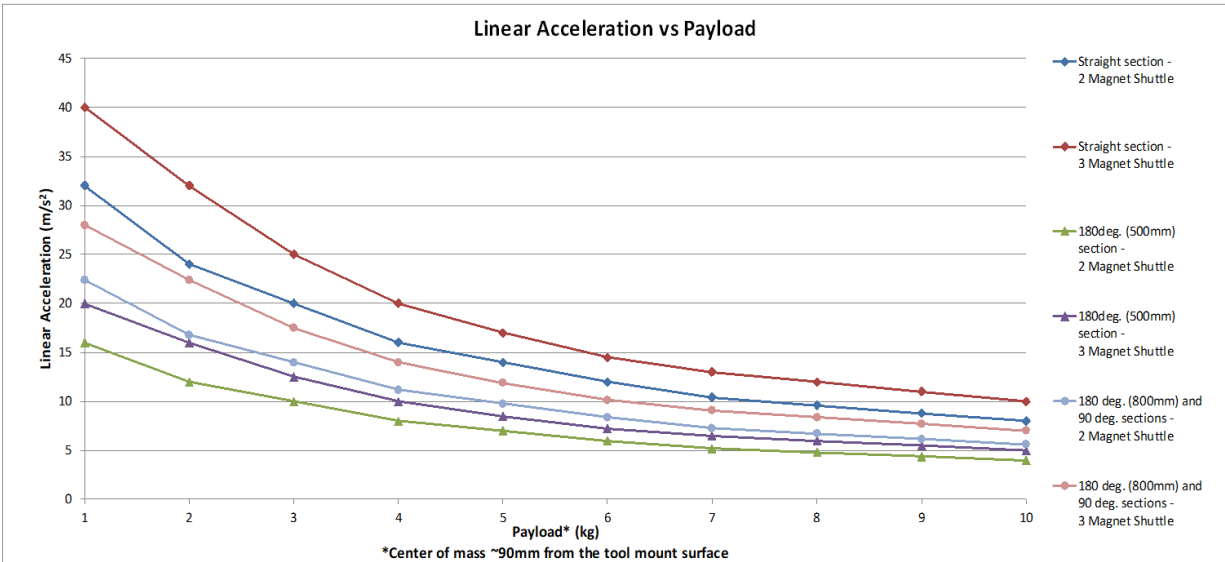

Shuttle Maximum Velocity vs. Payload on a Curved Section



On a 180 deg. section (500 mm) in a vertically mounted system (over/under configuration), the maximum velocity for a 3-magnet shuttle with a 4 kg payload with CoM ~90 mm is ~2.2m/s.

Contact SuperTrak CONVEYANCE for data related to your system specifications.

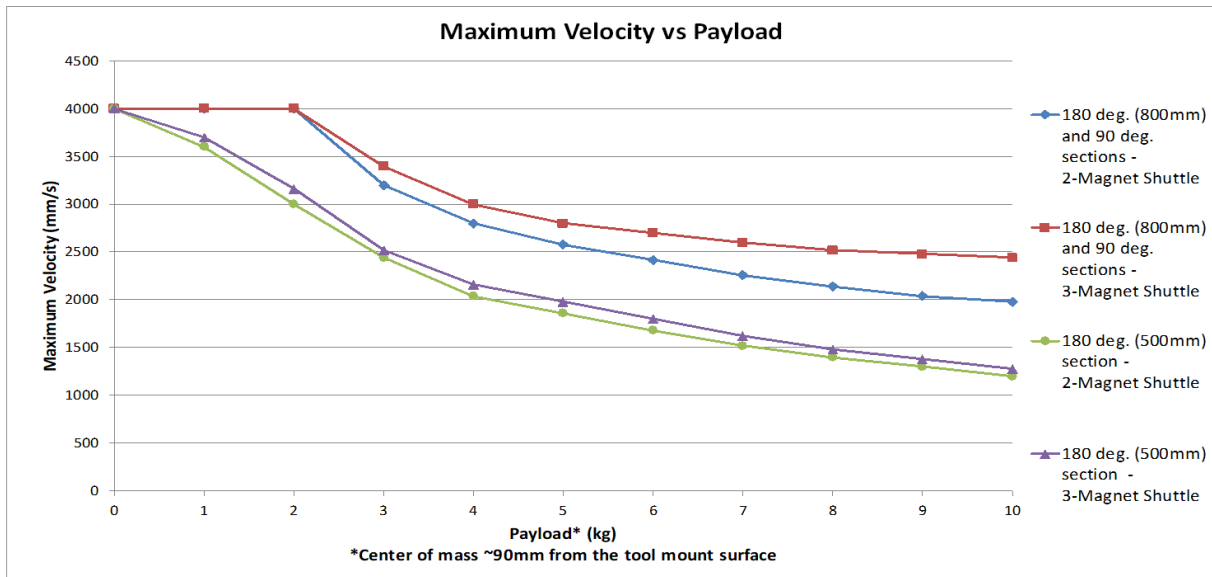

Shuttle Magnet Recommendations

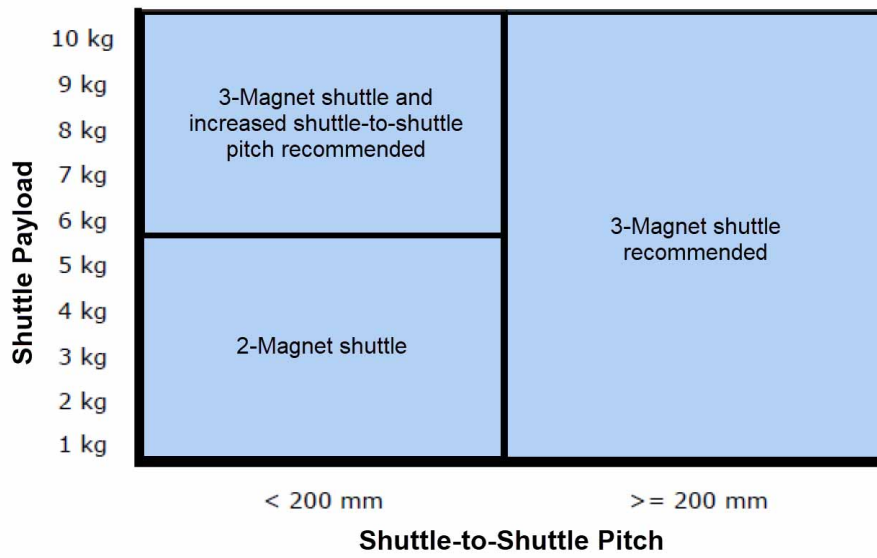

Positional Error at Constant Velocity



A 3σ standard deviation for following error is provided to show the +/- positioning tolerance of the shuttle 99.7% of the time.

Component ^a	Constant Velocity (mm/s)	Laser Interferometer ^b (+/- microns)	SuperTrak Encoders ^b (+/- microns)
Shuttle 2-magnet	20	31	23
	50	38	28
	100	48	32
	200	40	28
	500	69	25
	1000	63	35
	2000	154	124
	4000	181	136
Shuttle 3-magnet	20	31	24
	50	35	27
	100	51	35
	200	49	35
	500	75	28
	1000	58	32
	2000	156	101
	4000	198	97

- a. Calculations for shuttle motion predictability are based on the following test:
 - i. A shuttle is programmed to travel between the two (2) targets at various constant velocities (shown as Constant Velocity in the table).
 - ii. The shuttle motion is measured two (2) different ways: the SuperTrak encoders using the TrakMaster built-in Scope feature, and an external laser interferometer.
 - iii. A target is placed at the 0 mm (0 in.) and 1000 mm (39.37 in.) position on a straight section.
- b. The laser interferometer and SuperTrak encoder results vary from section-to-section due to manufacturing tolerances.
 The following settings and hardware versions were used during this test:
 - Control gains: P=8, I=0.4, D=4, FF=5, Moving Filter=0.5, Stationary Filter=0.5
 - Coil driver version: ACB3000-C02
 - Controller firmware version: 3.0.10.0 using the updated March 2019 force table.

Shuttle Magnetic Field Strength Measurement Locations

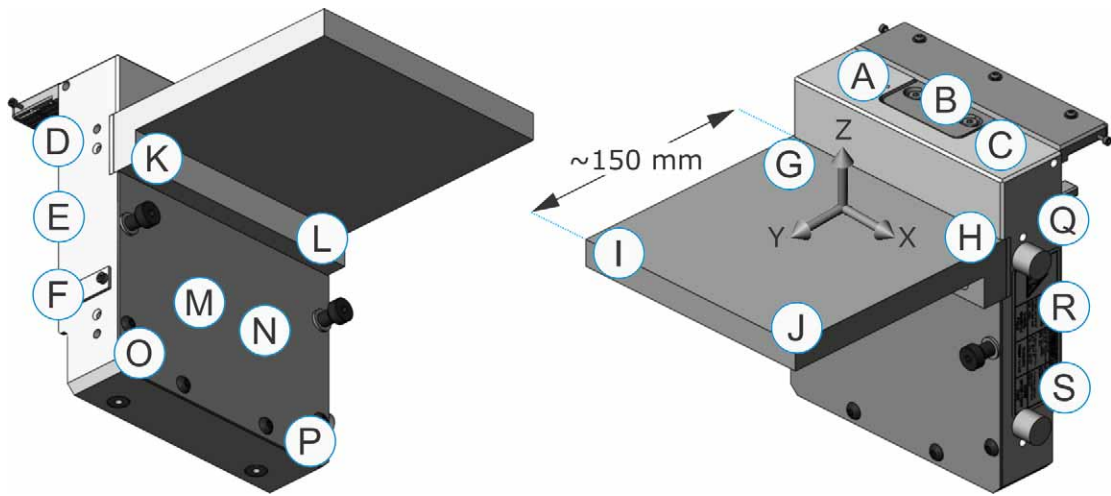

2-Magnet Shuttle Magnetic Measurement Values

All measurements in the following table are in Gauss units.

See [Shuttle Magnetic Field Strength Measurement Locations](#) on page 16 for the magnetic field strength measurement locations, and [Frame of Reference](#) on page 5 for a description of X, Y, and Z.

Location	2-Magnet Shuttle Enabled at a Standstill			2-Magnet Shuttle at Peak Force ^a		
	X	Y	Z	X	Y	Z
A	14	10	10	117	157	149
B	3	3.5	2.5	15	17	36
C	14	10	10	117	157	149
D	8	8	23	180	249	221
E	17	3	21	140	268	171
F	13	15	32	180	200	155
G	13	11	6	55	60	30
H	13	11	6	55	60	30
I	2.8	2.7	2.5	2.8	2.7	7
J	2.8	2.7	2.5	2.8	2.7	7
K	10	10	10	45	40	51
L	10	10	10	45	40	51
M	19	12	45	45	69	115
N	19	12	45	45	69	115
O	9	13	10	25	43	23
P	9	13	10	25	43	23
Q	8	8	23	180	249	221
R	17	3	21	140	268	171
S	13	15	32	180	200	155

a. Peak force measurements are captured when the coils are at maximum current. This electromagnetic field is a momentary field that could exist during acceleration at the maximum rate for a given payload.

3-Magnet Shuttle Magnetic Measurement Values

All measurements in the following table are in Gauss units.

See [Shuttle Magnetic Field Strength Measurement Locations](#) on page 16 for the magnetic field strength measurement locations, and [Frame of Reference](#) on page 5 for a description of X, Y, and Z.

Position	3-Magnet Shuttle Enabled at Standstill			3-Magnet Shuttle at Peak Force ^a		
	X	Y	Z	X	Y	Z
A	75	94	62	110	101	85
B	18	19	29	23	19	31
C	75	94	62	110	101	85
D	116	70	180	1210	270	606
E	250	38	280	1400	450	1135
F	64	65	90	260	96	100
G	40	50	19	43	53	24
H	40	50	19	43	53	24
I	5	4.5	5	5	4.5	6
J	5	4.5	5	5	4.5	6
K	90	90	128	90	112	157
L	90	90	128	90	112	157
M	124	31	120	134	31	140
N	124	31	120	134	31	140
O	22	38	3	22	39	4
P	22	38	3	22	39	4
Q	116	70	180	1210	270	606
R	250	38	280	1400	450	1135
S	64	65	90	260	96	100

a. Peak force measurements are captured when the coils are at maximum current. This electromagnetic field is a momentary field that could exist during acceleration at the maximum rate for a given payload.

Straight Section with FME Data Sheet

The straight section with front mounted electronics (FME) generates and regulates the electromagnetic field for the shuttles.

Features

- Bevels on the upper v-rail overlap at SuperTrak conveyance platform section transitions to provide a smooth, low-vibration transport surface for shuttles.
- Includes:
 - Encoders for contact-free position tracking of shuttles.
 - Three (3) 8 mm T-slots for mounting brackets, cable ducts, and other tooling.
 - Two (2) stands for stable mounting on a frame and smooth height adjustment.
 - Accessible electronics with door.
- Requires minimal maintenance (weekly cleaning of the flat wear strip).

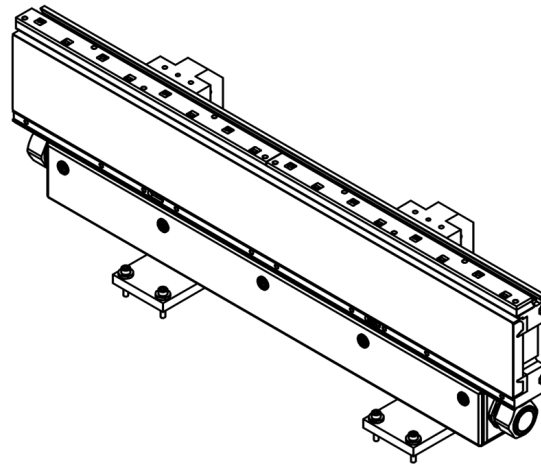

Part Numbers

Part	Part Number
Straight section with front-mounted electronics (with stands)	1060391
Straight section with front-mounted electronics (without stands)	1060387-S

Dimensions

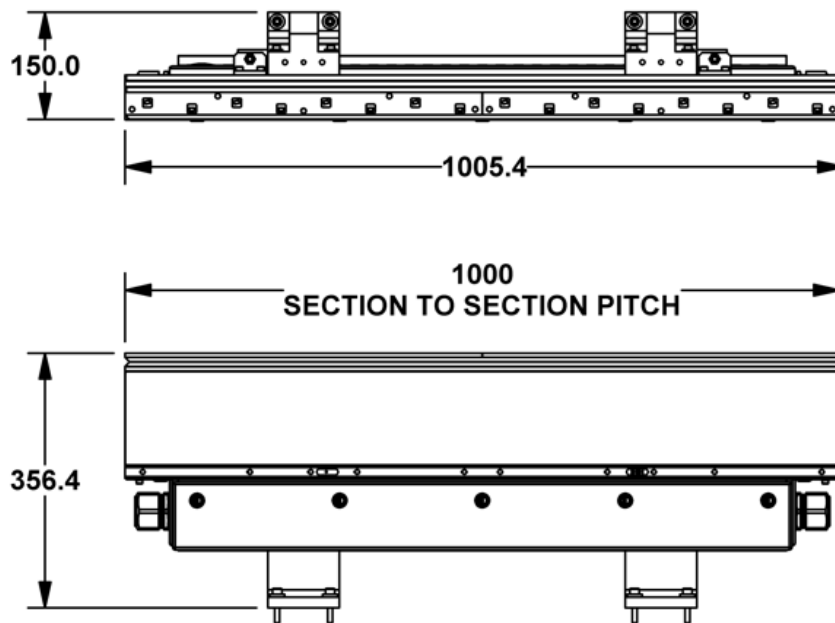

Dimensions for reference only. See SuperTrak Design Package for detailed drawings.

Technical Specifications

Specification	Value
24V digital bus FLA	250mA
Accelerating force (max.)	<ul style="list-style-type: none"> • 120 N (with 2-magnet shuttles) • 160 N (with 3-magnet shuttles)
Material	Aluminum anodized, stainless steel, polyamide (PA), polycarbonate (PC), epoxy resin.
Peak FLA (Amps) on 28VDC motor bus	100A
Voltage	<ul style="list-style-type: none"> • 28 VDC (motor) • 24 VDC (digital)
Weight	<ul style="list-style-type: none"> • 40.8 kg (90 lbs) without stands • 50.8 kg (112 lbs) with stands

Straight Section with FME Certifications

Region	Certifications
North America	Certified to UL 61800-5-1:2017 PowerDrive Systems, UL508:2013 & CAN/CSA C22.2 No 14:2013 Industrial Control.
European Economic Area (CE markings)	EU- Declaration of Conformity per LVD 2014/35/EU: EN 61800-5-1:2017 Power Drive Systems & EN 619:2010 Continuous Handling Equipment 2014/30/EU – Electromagnetic Compatibility: EN 61000-6-2:2005 Immunity, EN 61000-6-4:2011 Emissions

For detailed information on SuperTrak component certifications, visit <https://supertrakconveyance.com/certifications/>

This page is intentionally blank.

Straight Section with RME Data Sheet

The straight section with rear mounted electronics (RME) generates and regulates the electromagnetic field for the shuttles.

Features

- Bevels on the upper v-rail overlap at SuperTrak conveyance platform section transitions to provide a smooth, low-vibration transport surface for shuttles.
- Access to the electronics from the front is not required, since the electronics are mounted in the rear.
- Low-profile stands allow for a low profile installation.
- Includes:
 - Encoders for contact-free position tracking of shuttles.
 - Eight (8) slots for mounting brackets, cable ducts, and other tooling.
 - Two (2) stands for stable mounting on a frame and smooth height adjustment.
 - Rear mounted electronics, to allow for a horizontal or vertical (also known as over/under) installation.
- Options include:
 - Standard-height stands
 - Low-profile stands
- Requires minimal maintenance (weekly cleaning of the flat wear strip).

Straight section RME with standard-height stands

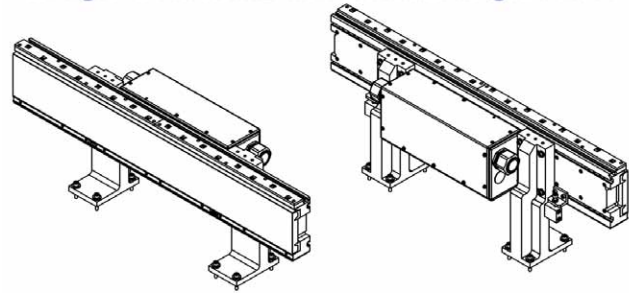

Straight section RME with low-profile stands

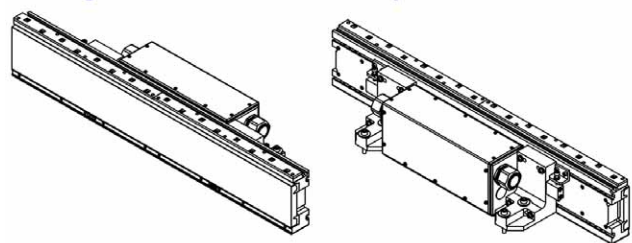

Part Numbers

Part	Part Number
Straight section with rear-mounted electronics and low-profile stand	125414648
Straight section with rear-mounted electronics and standard-height stand	125780473

Dimensions

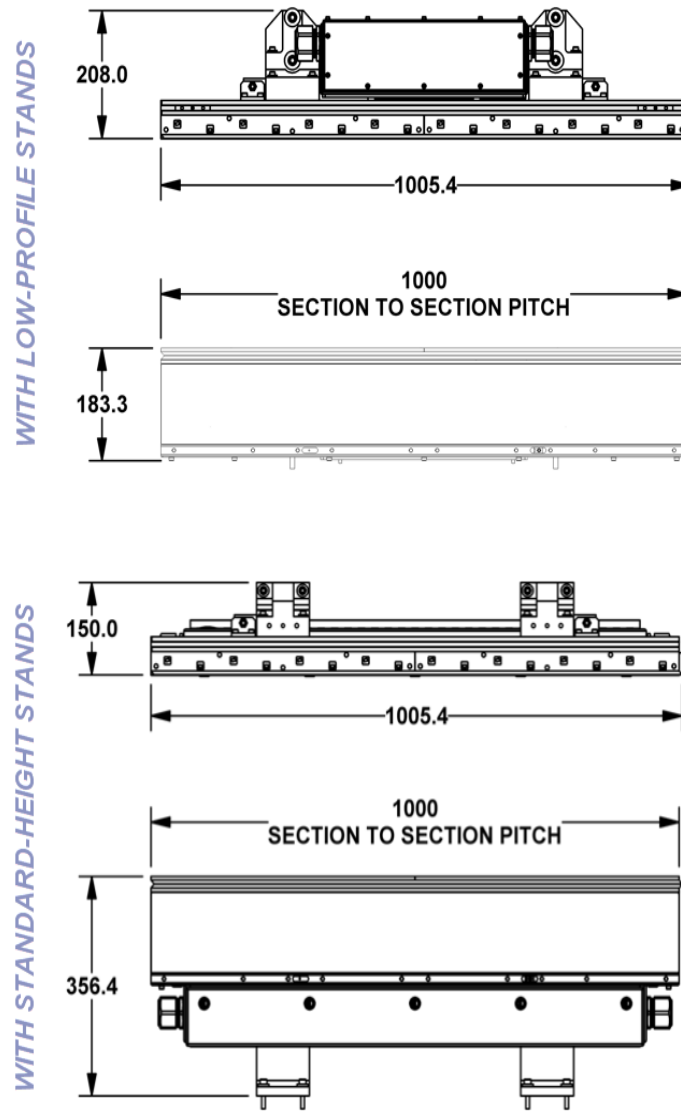

Dimensions for reference only. See SuperTrak Design Package for detailed drawings.

Technical Specifications

Specification	Value
24V digital bus FLA	250mA
Accelerating force (max.)	<ul style="list-style-type: none"> • 120 N (with 2-magnet shuttles) • 160 N (with 3-magnet shuttles)
Material	Aluminum anodized, stainless steel, polyamide (PA), polycarbonate (PC), epoxy resin.
Peak FLA (Amps) on 28VDC motor bus	100A
Voltage	<ul style="list-style-type: none"> • 28 VDC (motor) • 24 VDC (digital)
Weight	<ul style="list-style-type: none"> • 41 kg (90.4 lbs) without stands • 52 kg (114.6 lbs) with low-profile stands • 57 kg (125.7 lbs) with standard-height stands

Straight Section with RME Certifications

Region	Certifications
North America	Certified to UL 61800-5-1:2017 PowerDrive Systems, UL508:2013 & CAN/CSA C22.2 No 14:2013 Industrial Control.
European Economic Area (CE markings)	EU- Declaration of Conformity per LVD 2014/35/EU: EN 61800-5-1:2017 Power Drive Systems & EN 619:2010 Continuous Handling Equipment 2014/30/EU – Electromagnetic Compatibility: EN 61000-6-2:2005 Immunity, EN 61000-6-4:2011 Emissions

For detailed information on SuperTrak component certifications, visit <https://supertrakconveyance.com/certifications/>

This page is intentionally blank.

180 Deg. Section (500 mm) with Standard-Height Stands Data Sheet

The 180 deg. section with standard-height stands generates and regulates the electromagnetic field for the shuttles.

Features

- Bevels on the upper v-rail overlap at SuperTrak conveyance platform section transitions to provide a smooth, low-vibration transport surface for shuttles.
- Mountable in an upright orientation.
- Includes:
 - Encoders for contact-free position tracking of shuttles.
 - Access hole for power supply cable.
 - Three (3) stands for stable mounting on a frame, and smooth height adjustment.
 - Accessible electronic box by removing a cover.
- Requires minimal maintenance (weekly cleaning of the flat wear strip).

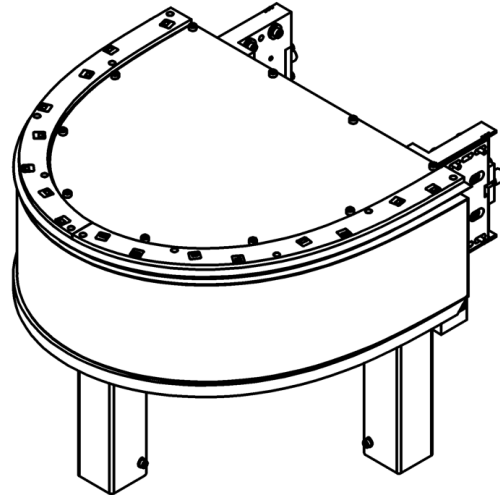

Part Number

Part	Part Number
180 deg. section with standard-height stands	1060638

Dimensions

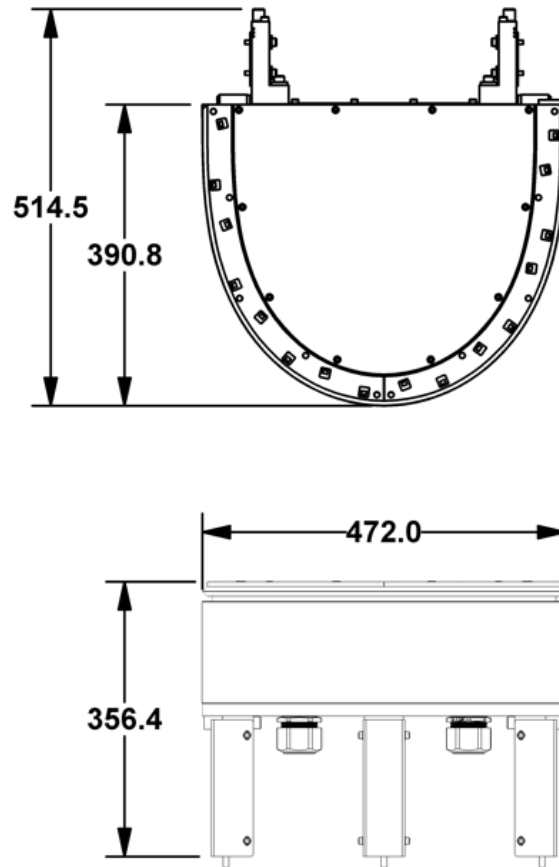

Dimensions for reference only. See SuperTrak Design Package for detailed drawings.

Technical Specifications

Specification	Value
24V digital bus FLA	500mA
Acceleration	See Shuttle Linear Acceleration vs. Payload on page 13.
Material	Aluminum anodized, stainless steel, polyamide (PA), polycarbonate (PC), epoxy resin.
Voltage	<ul style="list-style-type: none"> • 28VDC (motor) • 24VDC (digital)
Peak FLA (Amps) on 28VDC motor bus	150A
Weight	65 kg (143.3 lbs)

180 Deg. (500 mm) Section Certifications

Region	Certifications
North America	Certified to UL 61800-5-1:2017 PowerDrive Systems, UL508:2013 & CAN/CSA C22.2 No 14:2013 Industrial Control.
European Economic Area (CE markings)	EU- Declaration of Conformity per LVD 2014/35/EU: EN 61800-5-1:2017 Power Drive Systems & EN 619:2010 Continuous Handling Equipment 2014/30/EU – Electromagnetic Compatibility: EN 61000-6-2:2005 Immunity, EN 61000-6-4:2011 Emissions

For detailed information on SuperTrak component certifications, visit <https://supertrakconveyance.com/certifications/>

This page is intentionally blank.

180 Deg. Section (500 mm) with Low-Profile Stands Data Sheet

The 180 deg. section with low-profile stands generates and regulates the electromagnetic field for the shuttles.

Features

- Bevels on the upper v-rail overlap at SuperTrak conveyance platform section transitions to provide a smooth, low-vibration transport surface for shuttles.
- Mountable in an upright, or vertical over/under orientation.
- Includes:
 - Encoders for contact-free position tracking of shuttles.
 - Access hole for power supply cable access.
 - Accessible electronic box by removing a cover.
- Requires minimal maintenance (weekly cleaning of the flat wear strip).

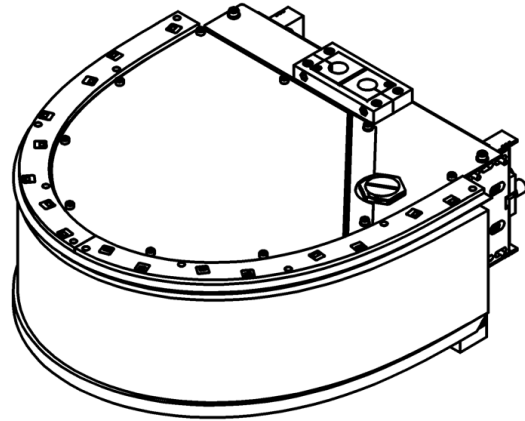

Part Number

Part	Part Number
180 deg. section with low-profile stands	125420930

Dimensions

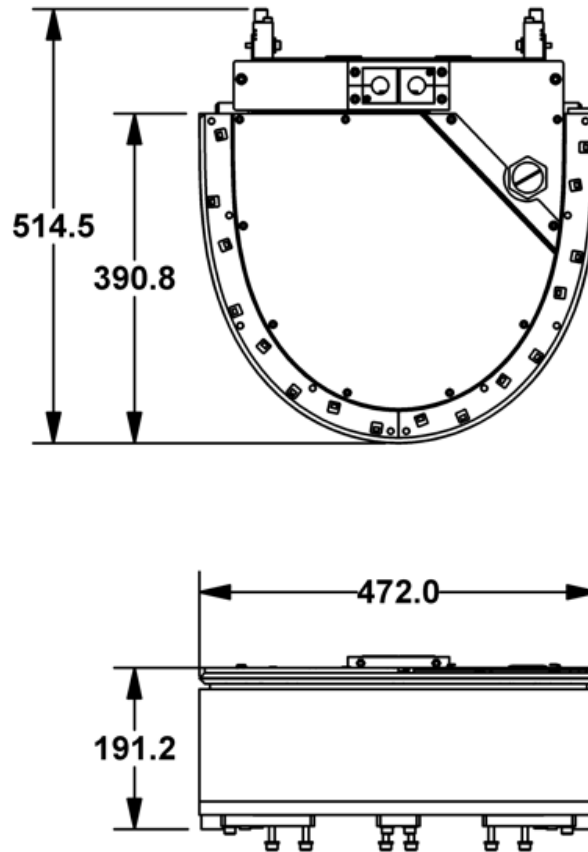

Dimensions for reference only. See SuperTrak Design Package for detailed drawings.

Technical Specifications

Specification	Value
24V digital bus FLA	500mA
Acceleration	See Shuttle Linear Acceleration vs. Payload on page 13.
Material	Aluminum anodized, stainless steel, polyamide (PA), polycarbonate (PC), epoxy resin.
Peak FLA (Amps) on 28VDC motor bus	150A
Voltage	<ul style="list-style-type: none"> • 28VDC (motor) • 24VDC (digital)
Weight	64 kg (141.1 lbs)

180 Deg. (500 mm) Section Certifications

Region	Certifications
North America	Certified to UL 61800-5-1:2017 PowerDrive Systems, UL508:2013 & CAN/CSA C22.2 No 14:2013 Industrial Control.
European Economic Area (CE markings)	EU- Declaration of Conformity per LVD 2014/35/EU: EN 61800-5-1:2017 Power Drive Systems & EN 619:2010 Continuous Handling Equipment 2014/30/EU – Electromagnetic Compatibility: EN 61000-6-2:2005 Immunity, EN 61000-6-4:2011 Emissions

For detailed information on SuperTrak component certifications, visit <https://supertrakconveyance.com/certifications/>

This page is intentionally blank.

180 Deg. Section (800 mm) Data Sheet

The 180 deg. section (800 mm) generates and regulates the electromagnetic field for the shuttles.

Features

- Bevels on the upper v-rail overlap at SuperTrak conveyance platform section transitions to provide a smooth, low-vibration transport surface for shuttles.
- Includes:
 - Encoders for contact-free position tracking of shuttles.
 - Access hole for power supply cable access.
 - Three (3) stands for stable mounting on a frame, and smooth height adjustment.
 - Accessible electronic box by removing a cover.
- Requires minimal maintenance (weekly cleaning of the flat wear strip).

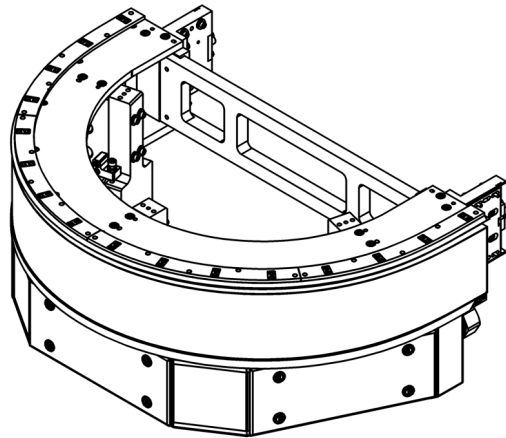

Part Number

Part	Part Number
180 deg. section	25232698

Dimensions

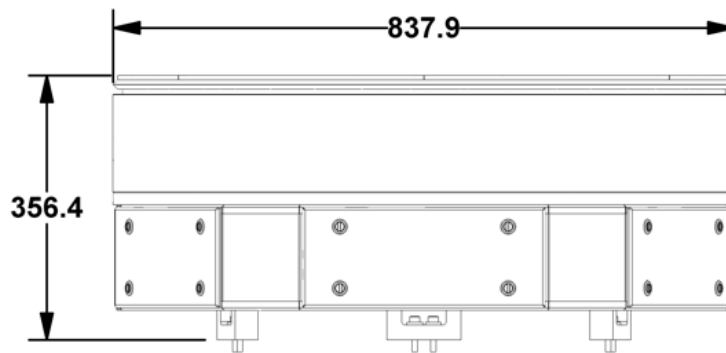
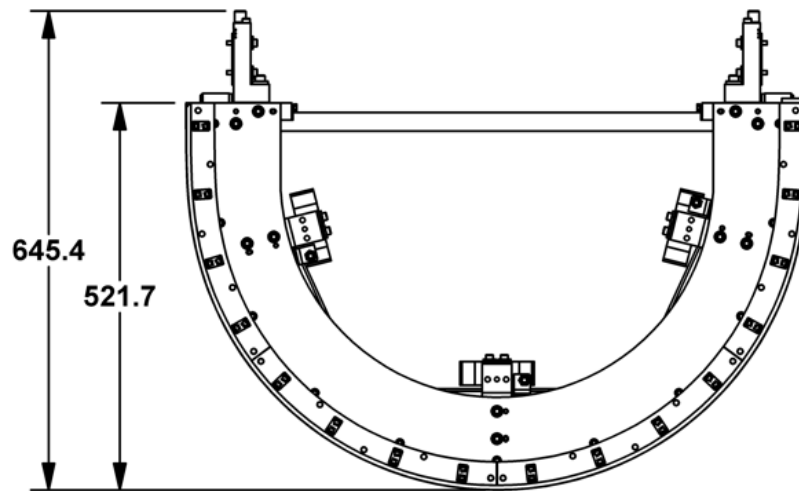

Dimensions for reference only. See SuperTrak Design Package for detailed drawings.

NOTE: If desired, the shipping brace (indicated in graphic at right) can be removed from the section after final installation.

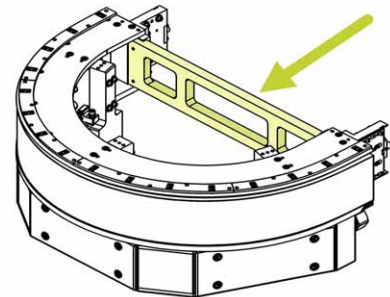

Technical Specifications

Specification	Value
24V digital bus FLA	500mA
Acceleration	See Shuttle Linear Acceleration vs. Payload on page 13.
Material	Aluminum anodized, stainless steel, polyamide (PA), polycarbonate (PC), epoxy resin.
Peak FLA (Amps) on 28VDC motor bus	150A
Voltage	<ul style="list-style-type: none"> • 28VDC (motor) • 24VDC (digital)
Weight	109.8 kg (242 lbs)

180 Deg. (800 mm) Section Certifications

Region	Certifications
North America	Certified to UL 61800-5-1:2017 PowerDrive Systems, UL508:2013 & CAN/CSA C22.2 No 14:2013 Industrial Control.
European Economic Area (CE markings)	EU- Declaration of Conformity per LVD 2014/35/EU: EN 61800-5-1:2017 Power Drive Systems & EN 619:2010 Continuous Handling Equipment 2014/30/EU – Electromagnetic Compatibility: EN 61000-6-2:2005 Immunity, EN 61000-6-4:2011 Emissions

For detailed information on SuperTrak component certifications, visit <https://supertrakconveyance.com/certifications/>

This page is intentionally blank.

90 Deg. Section Data Sheet

The 90 deg. section generates and regulates the electromagnetic field for the shuttles.

Features

- Bevels on the upper v-rail overlap at SuperTrak conveyance platform section transitions to provide a smooth, low-vibration transport surface for shuttles.
- Includes:
 - Encoders for contact-free position tracking of shuttles.
 - Access hole for power supply cable access.
 - Three (3) stands for stable mounting on a frame, and smooth height adjustment.
 - Accessible electronic box by removing covers.
- Requires minimal maintenance (weekly cleaning of the flat wear strip).

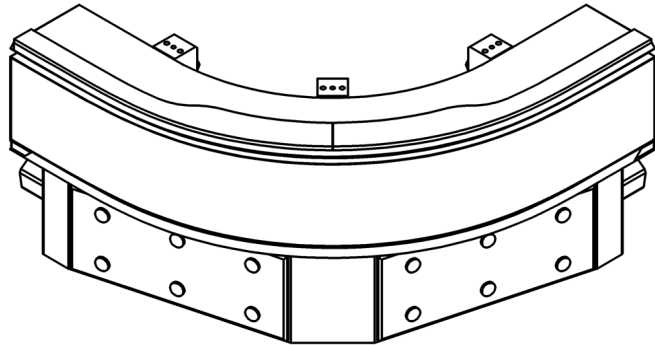

Part Number

Part	Part Number
90 deg. section	125426817

Dimensions

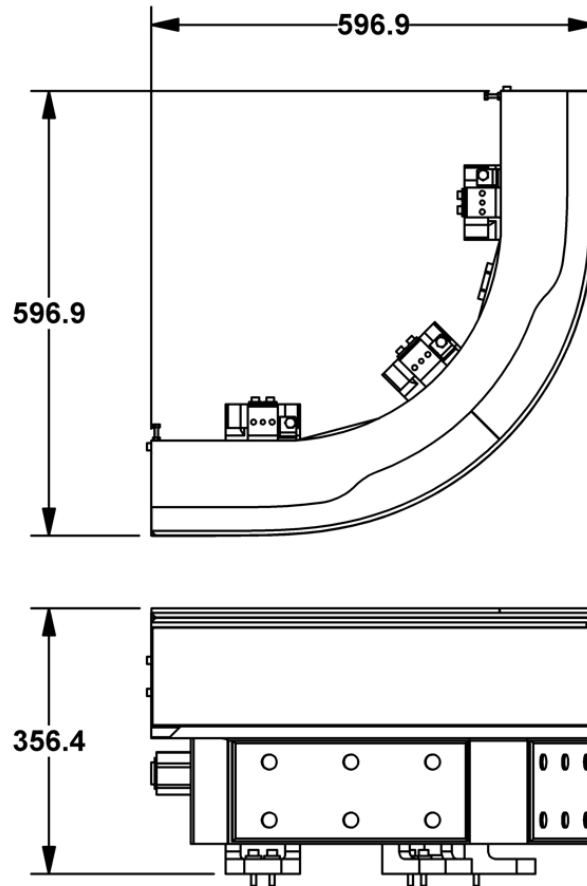

Dimensions for reference only. See SuperTrak Design Package for detailed drawings.

Technical Specifications

Specification	Value
24V digital bus FLA	250mA
Acceleration	See Shuttle Linear Acceleration vs. Payload on page 13.
Material	Aluminum anodized, stainless steel, polyamide (PA), polycarbonate (PC), epoxy resin.
Peak FLA (Amps) on 28VDC motor bus	100A
Voltage	<ul style="list-style-type: none"> • 28VDC (motor) • 24VDC (digital)
Weight	86.2 kg (190 lbs)

90 Deg. Section Certifications

Region	Certifications
North America	Certified to UL 61800-5-1:2017 PowerDrive Systems, UL508:2013 & CAN/CSA C22.2 No 14:2013 Industrial Control.
European Economic Area (CE markings)	EU- Declaration of Conformity per LVD 2014/35/EU: EN 61800-5-1:2017 Power Drive Systems & EN 619:2010 Continuous Handling Equipment 2014/30/EU – Electromagnetic Compatibility: EN 61000-6-2:2005 Immunity, EN 61000-6-4:2011 Emissions

For detailed information on SuperTrak component certifications, visit <https://supertrakconveyance.com/certifications/>

This page is intentionally blank.

Control Panel Data Sheet

The control panel provides controls for monitoring individual modules and shuttles.

Features

- Integration with the automation system safety circuit utilizes dual channel input with a feedback loop via provided terminals.
- Available in two (2) options:
 - 400Y230 VAC
 - 208Y120 VAC
- Includes:
 - An uninterruptible power supply (UPS).
 - Two (2) air filters.
 - An open interface to programmable logic controller (PLC): PROFINET, EtherNet/IP, EtherCAT, or PowerLink.

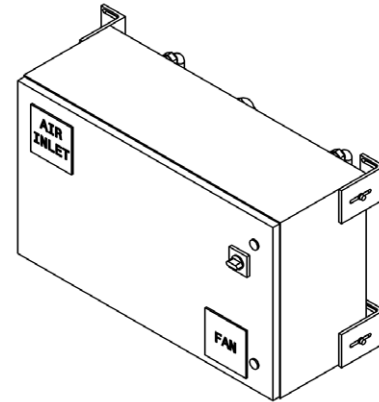

Part Number

The control panel part number is configurable; it consists of five parts:

[Base Panel]-[Breaker Kit]-[Communication]-[PC]-[P5-Expansion]

The graphic below shows the options for configuring a control panel part number.

Example: 25202161 - NA - EC - I3 - E6

Format: 25202161 - XX - XX - XX - XX

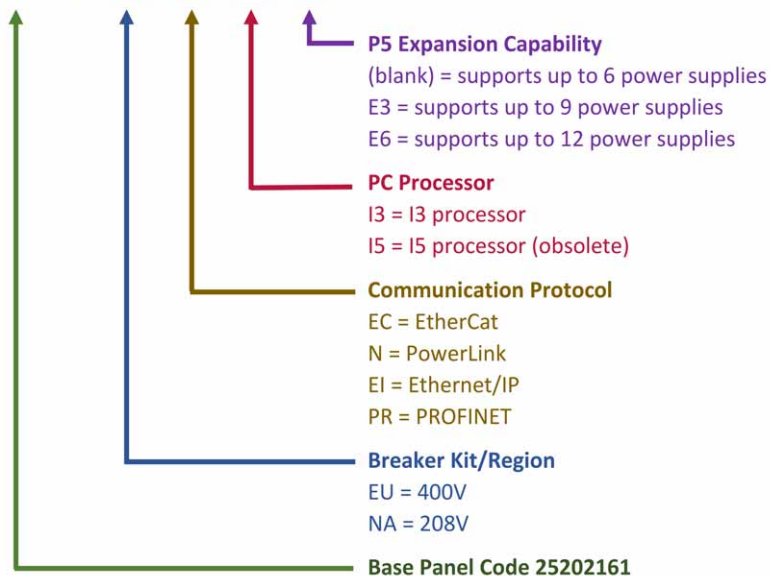

Dimensions

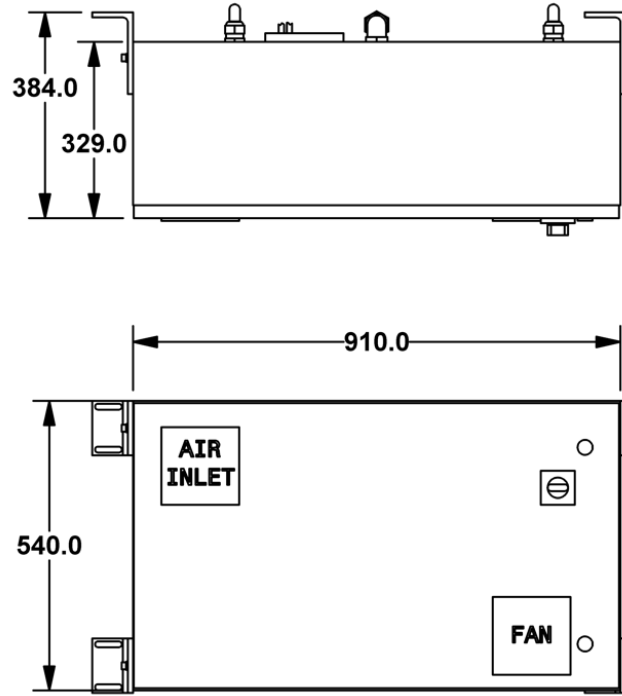

Dimensions for reference only. See SuperTrak Design Package for detailed drawings.

Technical Specifications

Specification	Value	
	EU	NA
Control voltage	<ul style="list-style-type: none"> • 24VDC (digital power supplied from the control panel) • 28VDC (motor power supplied from the power supplies) 	
Frequency	50/60 Hz	
Full load amps	36A	
Largest load	20A	
Line voltage	400Y230VAC+PE	208Y120VAC+PE
Materials	Steel sheet, lacquered, RAL7024, polyamide (PA)	
Phases	3 ph, 5-wire	
Short circuit current rating	5kA	
UPS current rating	15A	
UPS frequency	50/60 Hz	
UPS line voltage	24VDC	
Weight	70 kg (154.3 lbs)	

Control Panel Certifications

Region	Certifications*
North America	Certified to UL 508A:2014 Industrial Control Panels.
European Economic Area (CE markings)	EU- Declaration of Conformity per LVD 2014/35/EU: EN 60204-1 Electrical Equipment of Machines 2014/30/EU – Electromagnetic Compatibility: EN 61000-6-2:2005 Immunity, EN 61000-6-4:2011 Emissions

* Certifications for the control panel apply to part number 25202161 only. For detailed information on SuperTrak component certifications, visit <https://supertrakconveyance.com/certifications/>

This page is intentionally blank.

Power Supply Data Sheet

The power supply supplies power to straight and curved sections.

Features

- Provides a modular power system; adjust the number of SuperTrak conveyance platform power supplies based on the size and requirements of the system.
- Includes:
 - A 28VDC power output cable.
 - An AC power input plug.
 - One (1) air filter.
 - Connection cable for PLC monitoring (24V).
 - One (1) mounting plate and screws.
 - Four (4) mounting brackets.

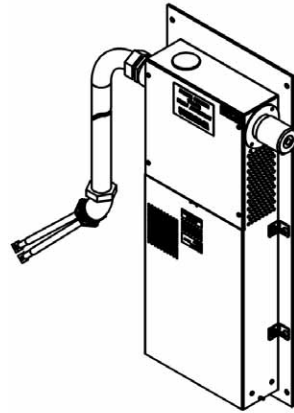

With back plate

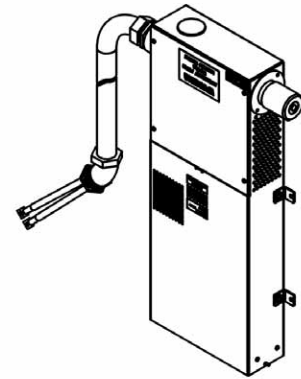

Without back plate

Part Numbers

Part	DC Output Cable Length ^a	Part Number
Power supply (with a mounting plate)	1.5 m	25195828
Power supply (without a mounting plate)	1.5 m	25270337
	5 m	25270337-5M
	8 m	25270337-8M

a. All power supplies on a track must have the same cable lengths. Do not use power supplies with varying cable lengths on the same system.

Dimensions (with back plate)

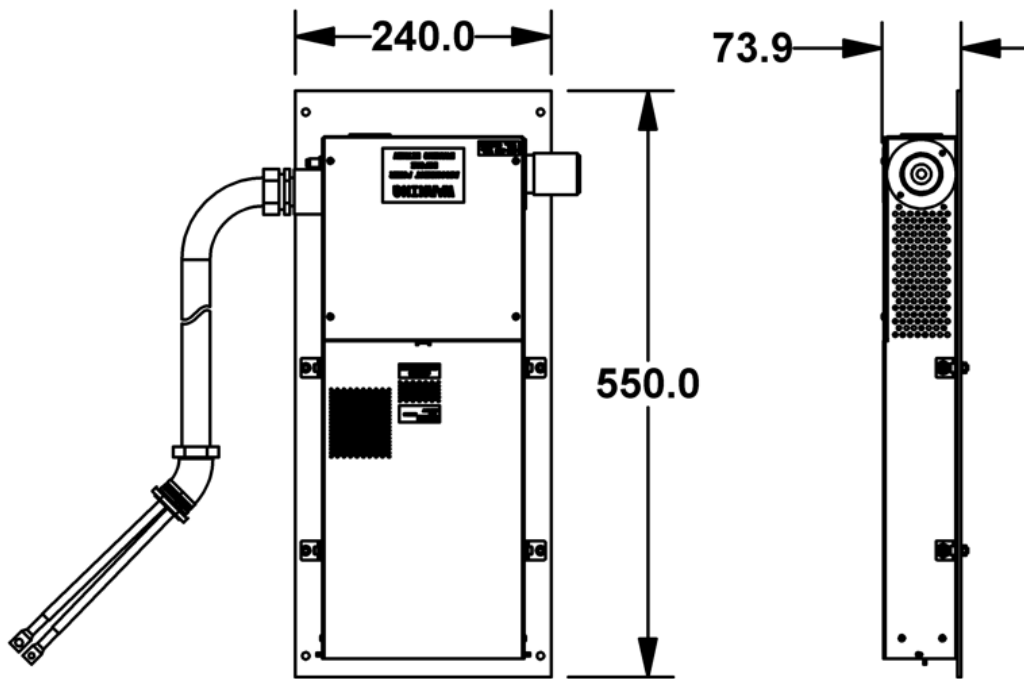

Dimensions (without back plate)

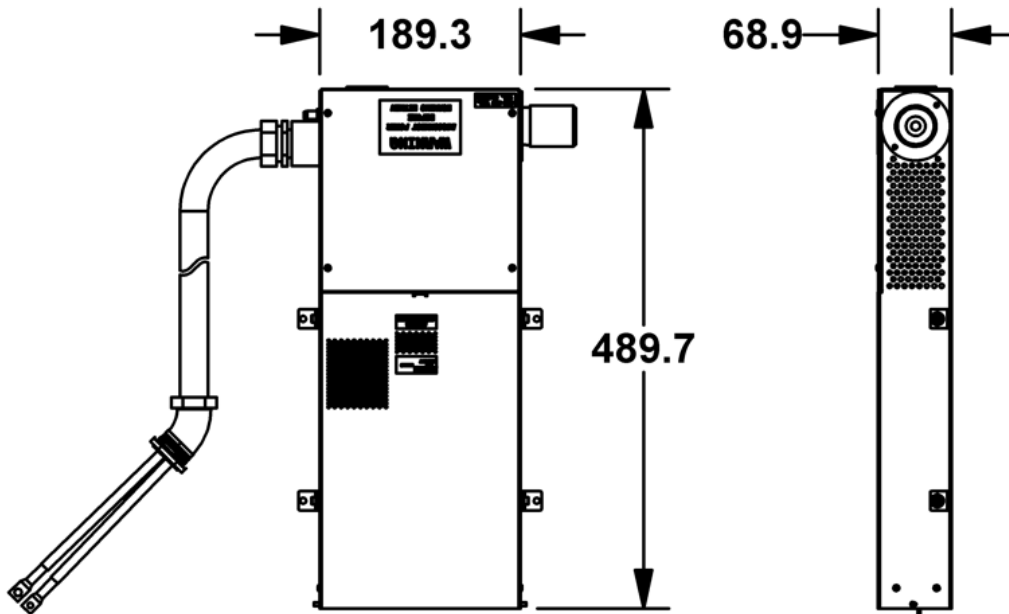

Dimensions for reference only. See SuperTrak Design Package for detailed drawings.

Technical Specifications

Specification	Value
Cable length	1500 mm (59.05 in.) - standard
	5000 mm (196.85 in.) - optional
	8000 mm (314.96 in.) - optional
Cable bend radius (inside)	63.5 mm (2.5 in.)
Class	IP20
Frequency	50/60Hz
Main voltage (input)	200-240VAC
Efficiency (%)	85% (typical)
Material	Aluminum, brass, nickel-plated, polyamide (PA), PUR
Max. number of power supplies	Application-dependent
Output wattage (continuous)	1500W
Output voltage	28VDC
Approximate weight: power supply with mounting plate and standard 1.5 M cable	9 kg (20 lbs)
Approximate weight: power supply with mounting plate and optional 5 M cable	13 kg (29 lbs)
Approximate weight: power supply with mounting plate and optional 8 M cable	15 kg (33 lbs)
SCCR	5kA

Power Supply Status Input

Overcurrent/Short-Circuit Protection

- Overcurrent protection is built in (105% of rated current, or 101% of peak current).
- The power supply will automatically recover when the fault condition is removed.
- If the overcurrent protection circuit operates continuously for 5 seconds, the output voltage will shut down.
 - To recover the output voltage, remove the condition that is causing the overcurrent, shut down the AC input voltage, wait more than 3 minutes and turn on the AC input again.

Overvoltage Protection

- Overvoltage protection is built in ($V_o + 5.6 - 11.2$).
- If the overvoltage protection circuit is activated, shut down the input voltage, wait more than 3 minutes and turn on the AC input again to recover the output voltage.

Thermal Protection

The built-in thermal protection circuit will be activated under the following conditions and will shut down the output when:

- The temperature continues to exceed the values determined by the derating curve. (50°C @ 100% Loading, 71°C @ 50% Loading)
- The fan stops, or air flow is blocked from the fan.

If the thermal protection circuit is activated, shut off the input voltage and eliminate the overheating conditions. To recover the output voltage, allow the unit to fully cool down (~10min) before reapplying the input voltage.

Power Supply Certifications

Region	Certifications*
North America	Certified to UL 61010-1:2018, CAN/CSAC22.2 No. 61010-1:2018 & UL 508:2013 Industrial Control.
European Economic Area (CE markings)	EU- Declaration of Conformity per LVD 2014/35/EU: EN 61010:2010 Safety Electrical Equipment for Measurement, Control. 2014/30/EU – Electromagnetic Compatibility: EN 61000-6-2:2005 Immunity, EN 61000-6-4:2011 Emissions

* Certifications for the power supply apply to part number 25270337 (and 25270337-XX where XX represents alternate DC cable length) only. For detailed information on SuperTrak component certifications, visit <https://supertrakconveyance.com/certifications/>

IR Reader Components (Optional) Data Sheet

The infrared (IR) components are optional. The IR reader mount assembly allows for easy installation of the IR reader on a SuperTrak conveyance platform. The IR tags assign a unique shuttle ID to each shuttle, and the IR reader reads the IR tag on the shuttle.

Features

- Simplifies SuperTrak conveyance platform recovery after a complete cold start.
- Provides data integrity when shuttles are manually removed.
- Provides tracking of individual shuttles.
- Allows shuttle IDs to be read “on-the-fly”: shuttles do not stop at the IR reader assembly.
- Batteries are not required. The assembly induces the necessary power into the tags for reading purposes.
- External PLC programming is not required. Integration of the IR reader assembly with the SuperTrak conveyance platform is plug-and-play.
- Options include:
 - IR tag (read-only)
 - IR reader
 - IR reader mount assembly

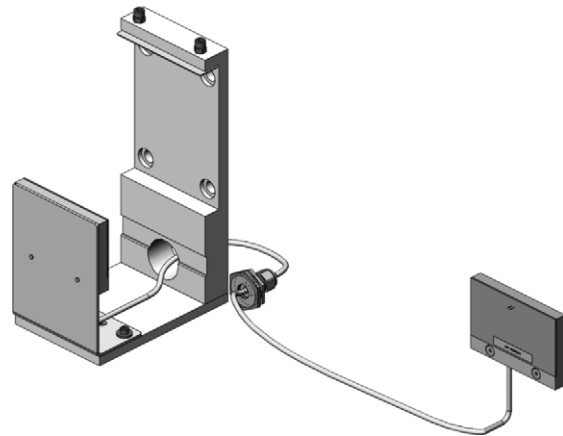

Part Numbers

Part	Part Number
IR reader (no mount)	SP-25202314
IR reader mount assembly (with IR reader)	25202309
IR reader mount assembly (without IR reader)	SP-4727653
IR tag (read-only)	SP-1061122

Dimensions

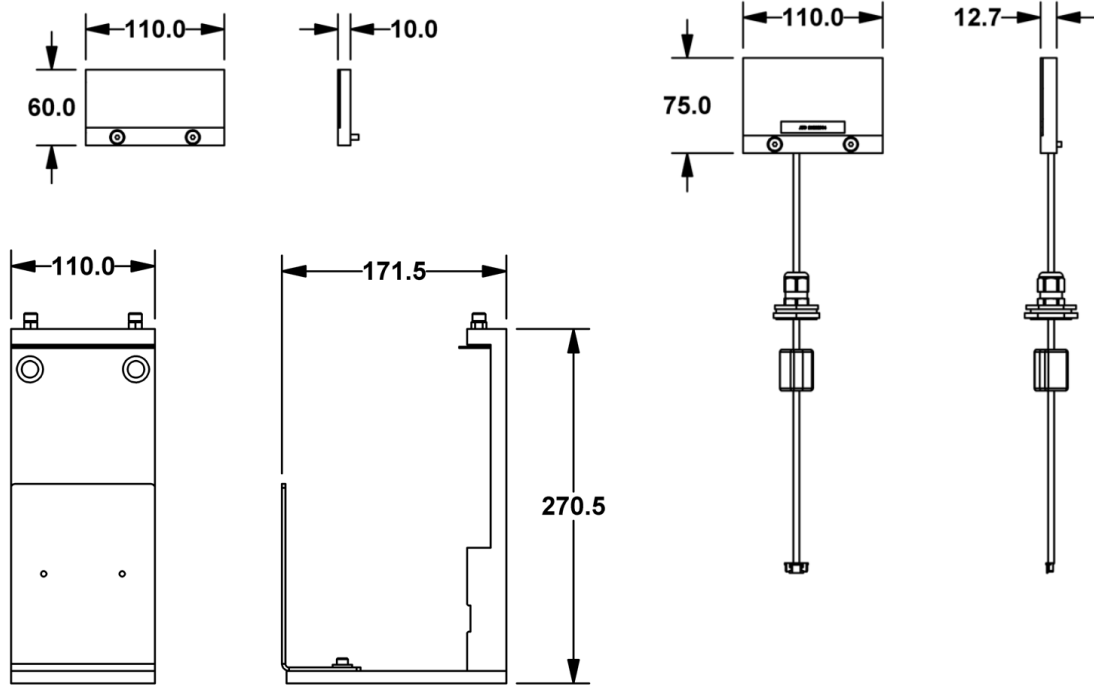

Dimensions for reference only. See SuperTrak Design Package for detailed drawings.

Technical Specifications

Specification	Value		
	IR Tag	IR Reader Head	Assembly Mount
Laser		Class 1	
Mass	0.1 kg (0.2 lbs)	0.3 kg (0.7 lbs)	2.4 kg (5.3 lbs)
Material	Polyoxymethylene (POM)	polyoxymethylene (POM), brass, nickel-plated, PVC	Aluminum, anodized, steel

Shuttle Setup Tools (Optional) Data Sheet

The shuttle setup tools are optional SuperTrak conveyance platform tools that allow you to align and calibrate shuttle encoder strips.

Features

- Provides easy alignment and calibration of shuttle encoder strips.
- Includes the following tools:
 - Shuttle setup stationary mount, which provides a fixed mounting surface for the shuttle setup tools.
 - Shuttle setup adjustable chip finder, which accurately positions a shuttle setup stationary mount in relation to a defined encoder.
 - Shuttle setup removable locate, which allows for adjustment of the shuttle encoder strip assembly.

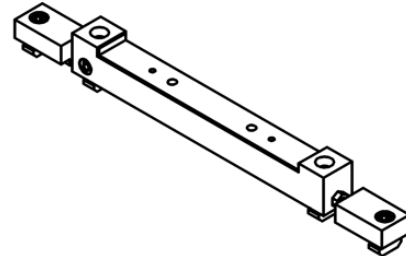
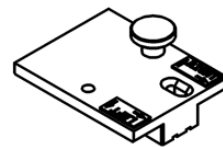
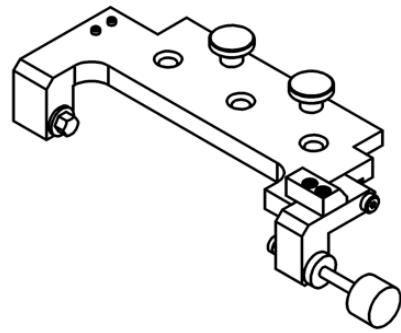

Part Numbers

Part	Part Number
Shuttle setup tools	4736082

Dimensions

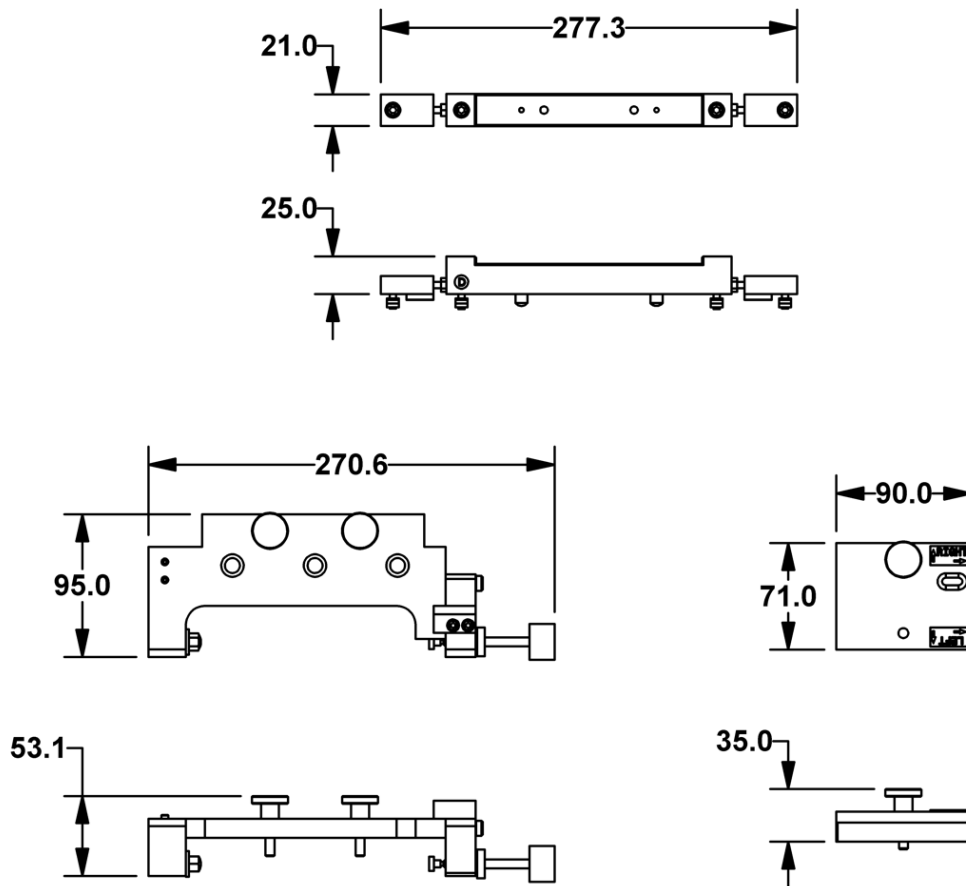

Dimensions for reference only. See SuperTrak Design Package for detailed drawings.

Technical Specifications

Specification	Value
Mass	2.2 kg (4.9 lbs)
Material	Aluminum, steel

Shuttle Removal Tool (Optional) Data Sheet

The shuttle removal tool allows for quick and easy removal of shuttles from straight sections or 180 deg. sections.

Features

- Provides leverage to easily overcome the magnetic forces of the shuttles.
- Includes two locking latches to safely secure the shuttle.

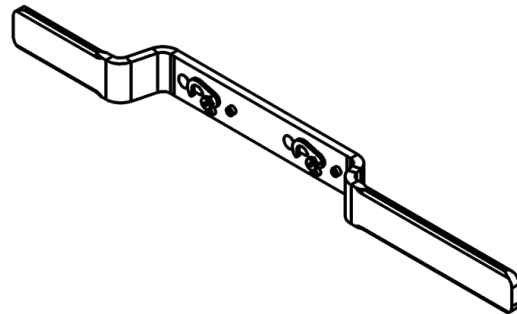

Part Numbers

Part	Part Number
Shuttle removal tool	25172729

Dimensions

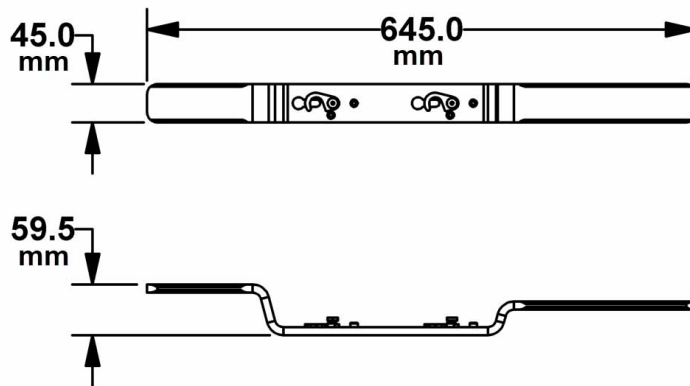

Dimensions for reference only. See SuperTrak Design Package for detailed drawings.

Technical Specifications

Specification	Value
Material	Aluminum
Weight	0.8 kg (1.76 lbs)

This page is intentionally blank.

SuperTrak GEN3 Frames Data Sheet

The SuperTrak GEN3 frames provide a stable adjustable mounting foundation for straight sections and curved sections.

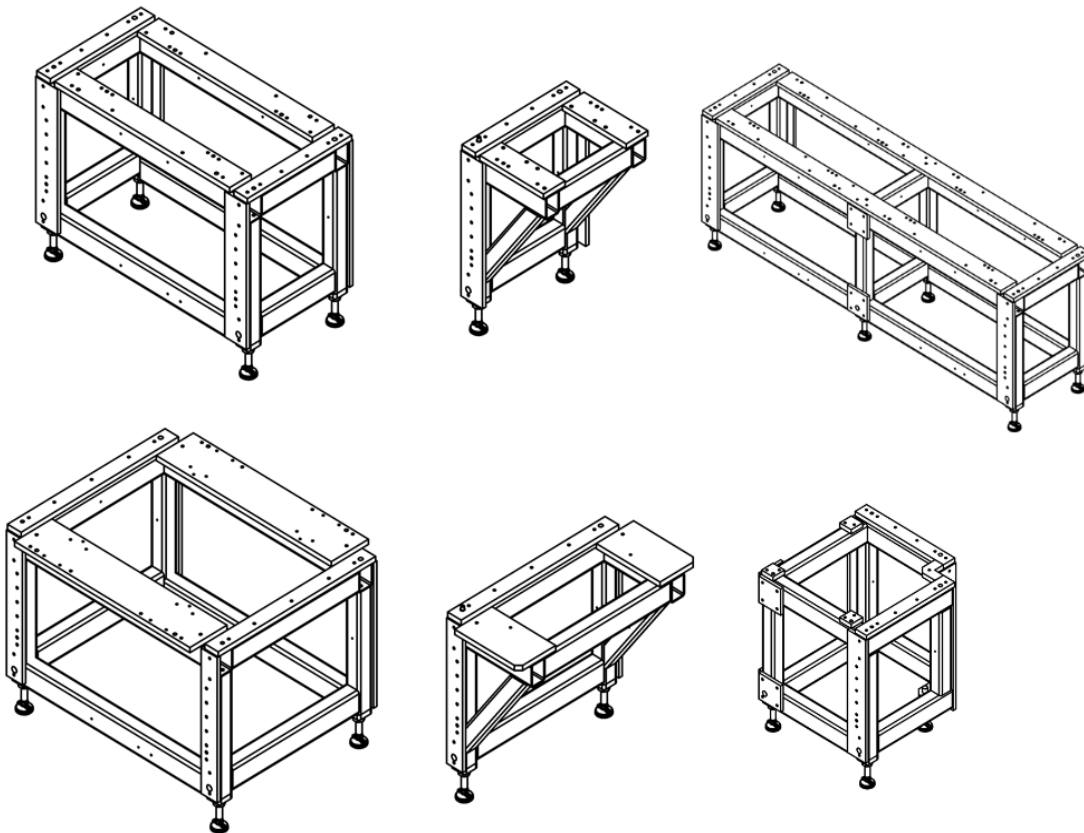

Features

- Robust welded frame.
- Available in six formats to accommodate the different types and widths of track sections.
- Modular design
- Includes:
 - Adjustable leveling feet.
 - Threaded holes for attaching plates, cross-braces, side connection plates, and control panels.
 - Connection plate kits and section mounting kits

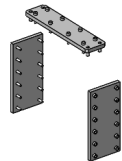
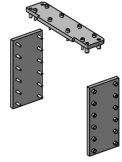

Part Numbers and Weights

Part		Weight	Part Number
SuperTrak GEN3 Frame 500 x 1 m		134 kg	125354246
SuperTrak GEN3 Frame 500 x 2 m		229 kg	125767467
SuperTrak GEN3 Frame 500 Compact		63 kg	125354247
SuperTrak GEN3 Frame 800 x 1 m		161 kg	125721554
SuperTrak GEN3 Frame 800 Compact		77 kg	700066211
SuperTrak GEN3 Frame 90 Deg.		107 kg	125777464

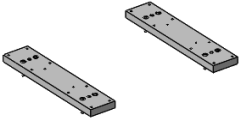
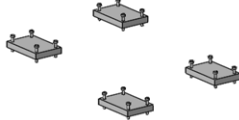
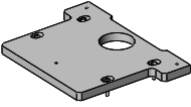
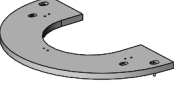
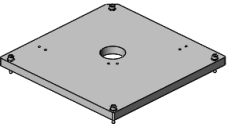
Part	Image	Weight	Part Number
Middle Connection Kit (500)		18 kg	125354248
End Connection Kit (500)		18 kg	125354250
Middle Connection Kit (800)		21 kg	125659677
Straight Section Mounting Kit (500)		7 kg	125354251
Straight Section Mounting Kit (800)		4 kg	25249251
Mounting Kit - 180 Deg. Section (500)		8 kg	125354252
Mounting Kit - 180 Deg. Section (800)		12 kg	125721562
Mounting Kit - 90 Deg. Section		14 kg	700052303

All mounting kits include mounting hardware.

Dimensions

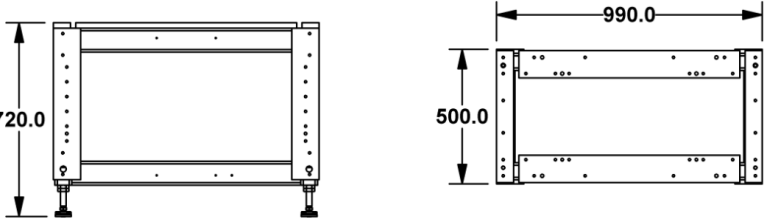
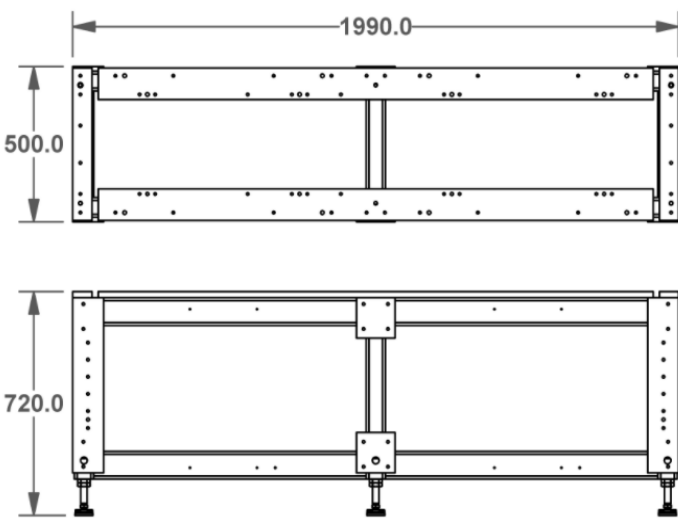
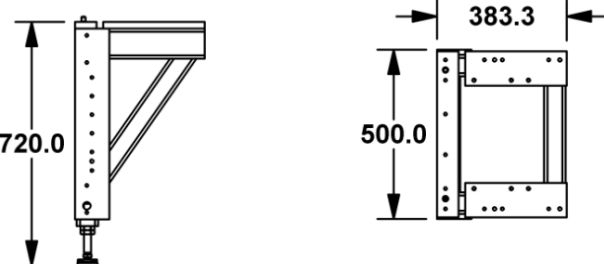
Frame Segment	Dimensions
<p>SuperTrak GEN3 Frame 500 x 1 m</p>	
<p>SuperTrak GEN3 Frame 500 x 2 m</p>	
<p>SuperTrak GEN3 Frame 500 Compact</p>	

Frame Segment	Dimensions	
SuperTrak GEN3 Frame 800 x 1 m		
SuperTrak GEN3 Frame 800 Compact		
SuperTrak GEN3 Frame 90 Deg.		

Dimensions for reference only. See SuperTrak Design Package for detailed drawings.

Technical Specifications

Specification	Value	
	SuperTrak GEN3 frame - 1 m	SuperTrak GEN3 frame - 180 Deg. Mount
Mass	135 kg (297.6 lbs)	62 kg (136.7 lbs)
Material	Steel lacquered RAL7024, zinc die casting, steel, galvanized	

This page is intentionally blank.

Additional Components for Over-Under Configurations— Data Sheet

Systems set up in an over-under configurations require specific components for covers and mounting.

Components, Part Numbers, and Specifications

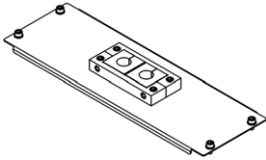
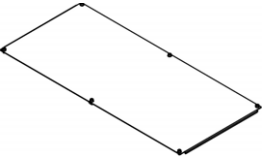
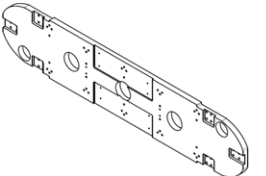
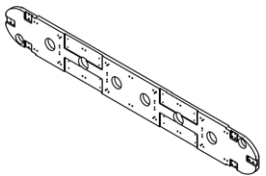
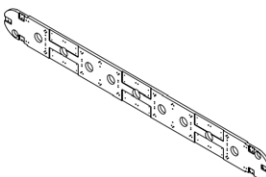
Part	Part number	Image	Material(s)	Weight & Dimensions
Over-Under Cover, Short - ASSY	125422766		Stainless Steel, Polyamide, Elastomer, Mild steel (galvanically zinc plated)	.8 kg 389.7 x 130.0 x 26.4 mm
Over-Under Cover, Long - ASSY	125451170		Stainless Steel, Cold Rolled Steel	4.2 kg 868.0 x 389.7 x 18.6 mm
Over-Under Wall Plate, 1M	125454767		Cast Aluminum	39 kg 1628.5 x 342.0 x 31.8 mm
Over-Under Wall Plate, 2M	125454761		Cast Aluminum	64.4 kg 2628.5 x 342.0 x 31.8 mm
Over-Under Wall Plate, 3M	125414884		Cast Aluminum	89.7 kg 3628.5 x 342.0 x 31.8 mm

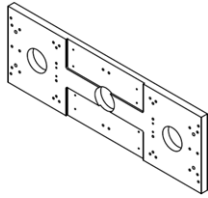
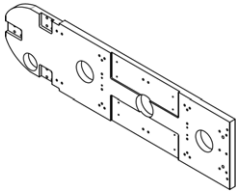
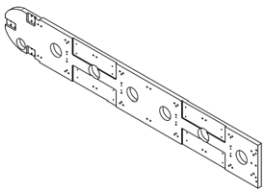
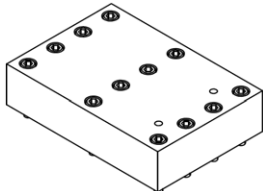
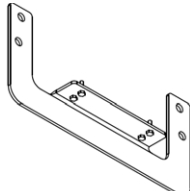
Part	Part number	Image	Material(s)	Weight & Dimensions
Over-Under Wall Plate (Middle Connector), 1M	125525192		Cast Aluminum	25.3 kg 999.5 x 342.0 x 31.8 mm
Over-Under Wall Plate, 1M+E	125525190		Cast Aluminum	32.1 kg 1314.0 x 342.0 x 31.8 mm
Over-Under Wall Plate, 2M+E	125525065		Cast Aluminum	57.5 kg 2314.0 x 342.0 x 31.8 mm
Match Plate Assembly	125790081		Aluminum, Cold Rolled Steel	4.9 kg 220.0 x 152.4 x 50.8 mm
Lift Bracket with Hardware	700082892		Cold Rolled Steel, Mild Steel (galvanically zinc plated)	2.6 kg 660.0 x 305.0 x 82.9 mm

Dimensions for reference only. See SuperTrak Design Package for detailed drawings.

Interconnect Kit (Straight Section to Straight Section) Data Sheet

The interconnect kit provides all the necessary hardware to physically connect two (2) adjacent straight sections with FME mechanically, electrically, and functionally.

Features

The following items are included:

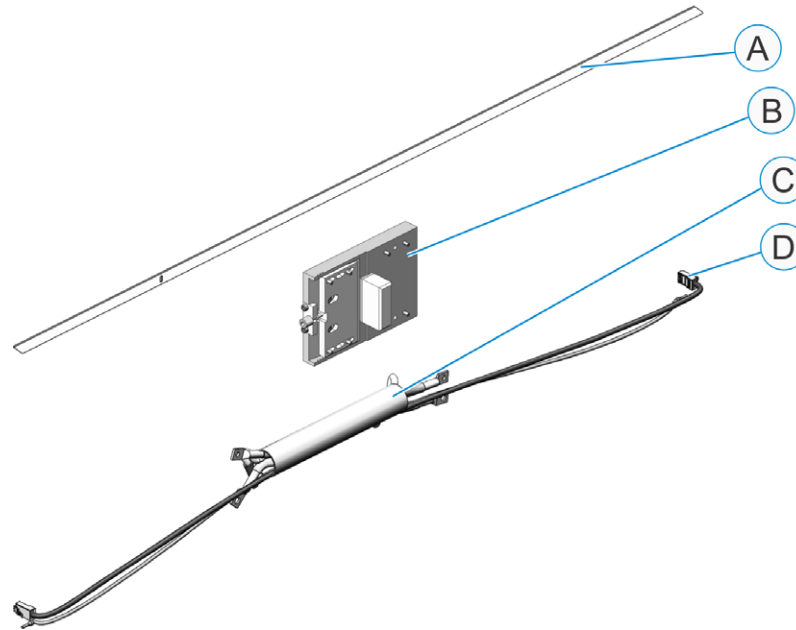

A	Flat rail	C	Straight-to-straight electrical interconnect
B	Wedge adjust	D	Ethernet network cable ^a

Part Numbers

Part	Part Number
Ethernet network cable ^a	SP-3708400
Interconnect kit	SP-4217881 (FME to FME)
	SP-5191723 (RME to RME)
Straight-to-straight electrical interconnect	SP-1060659
Wear strip	SP-1060669
Wedge adjust	SP-1060643

a. The Ethernet network cable is included with the straight-to-straight electrical interconnect, but is also offered separately because it may be damaged during assembly or maintenance.

This page is intentionally blank.

Interconnect (SuperTrak Control Panel to Curved Section) Data Sheet

The control panel to curved section interconnect provides the wires that are required between the curved section and the control panel. (View the SuperTrak GEN3™ Operations and Maintenance Manual at <https://supertrakconveyance.com/customer-portal/> for additional information about Gateway network connections.)

Features

The following items are included:

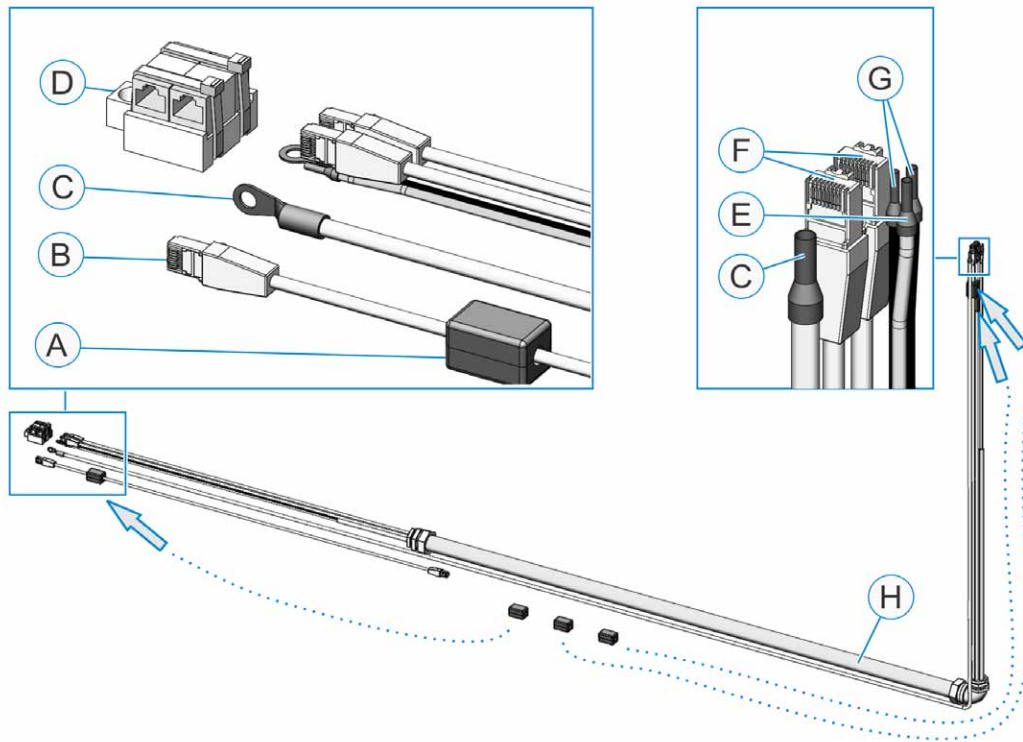

A	Ferrite (1 of 3)	E	Common connection
B	Left network patch cable	F	Two (2) 3 m ^a Ethernet cables - left and right network cables
C	3 m ^a ground cable ^b	G	24VDC digital power
D	F-F coupler (1 of 2)	H	1.2 m ^c Conduit

a. Optional length of 7.6 m.

b. The ground wire is 16mm².

c. Optional lengths of 2 m, and 6.5 m.

Part Numbers

Part	Part Number
1.2 m control panel to curved section interconnect	25240470
2 m control panel to curved section interconnect	125362696
6.5 m control panel to curved section interconnect	25221246

Gateway Board (ACB3040-C01) Data Sheet

Each SuperTrak GEN3™ motor section contains an ACB3040 Gateway board to manage communications and servo control. (The 180 deg. (800 mm) section has two Gateway boards.) Communication with the SuperTrak™ controller and adjacent Gateway boards are made via the proprietary Gateway-Gateway Serial Link (GGSL) network. This data sheet contains the specifications for the C01 version of the Gateway Board. For information on other versions of the Gateway Board, contact SuperTrak Technical Support.

Features

- The Gateway board handles low-level control of the motor and position feedback systems via interfaces with a pair of coil driver boards and a pair of encoder boards.
- The Gateway board features Xilinx Spartan-6 FPGA and CoolRunner-II CPLD devices that work in concert to manage communications and section control.

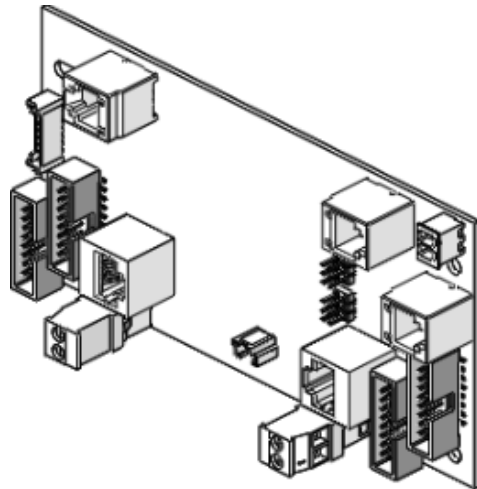

Part Number

Part	Type	Part Number
SuperTrak GEN3™ Gateway board	ACB3040	SP-25211309

Dimensions

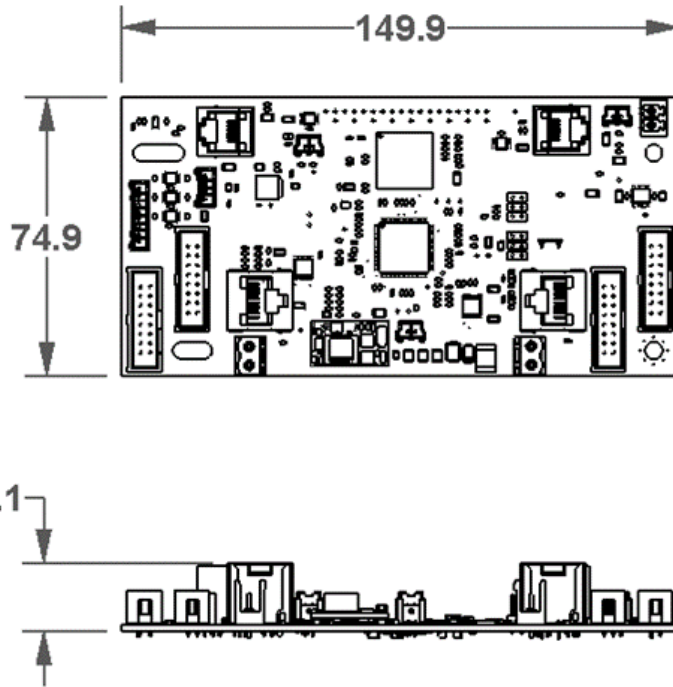

Dimensions for reference only.

Technical Specifications

Specification		Value			
Weight		0.080kg			
Environmental conditions and limits		Same as for track sections—see the SuperTrak GEN3™ Operations and Maintenance Manual at https://supertrakconveyance.com/customer-portal/ for more information.			
Interfaces		<ul style="list-style-type: none"> • 2x coil driver proprietary serial interfaces • 2x encoder board interfaces • 2x network interfaces for Gateway network uplink & downlink • 1x JTAG programming interface 			
Power	Parameter	Minimum	Typical	Maximum	Units
	Input DC Voltage	23.8	24.0	25.2	V
	Input current	-	-	250	mA

Coil Driver Board (ACB3000-E01) Data Sheet

Each SuperTrak GEN3™ motor section contains multiple ACB3000 Coil Driver boards to commutate current in motor coils. The 180 deg. (800 mm) sections have three (3) coil driver boards while all other types of sections have two (2) coil driver boards. The coil driver receives commands and returns sensor values to the Gateway board via proprietary serial links. This data sheet contains the specifications for the E01 version of the coil driver board. For information on other versions of coil driver boards, contact SuperTrak Technical Support.

Features

- Xilinx CoolRunner-II CPLD devices providing individual control of ten (10) motor coils.
- Motor temperature and coil current sensors with extreme limit sensing and protection.

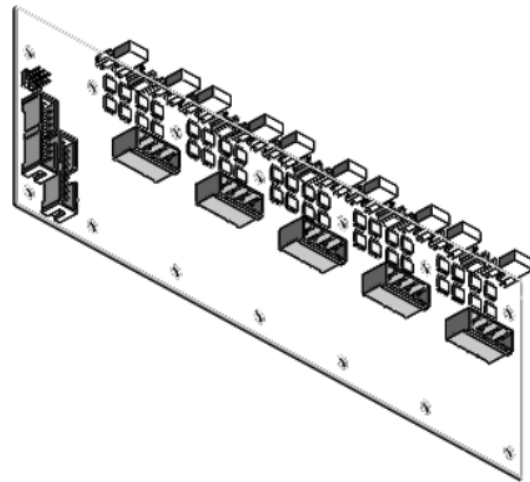

Part Number

Part	Type	Part Number
SuperTrak GEN3™ coil driver board	ACB3000	SP-25211311

Dimensions

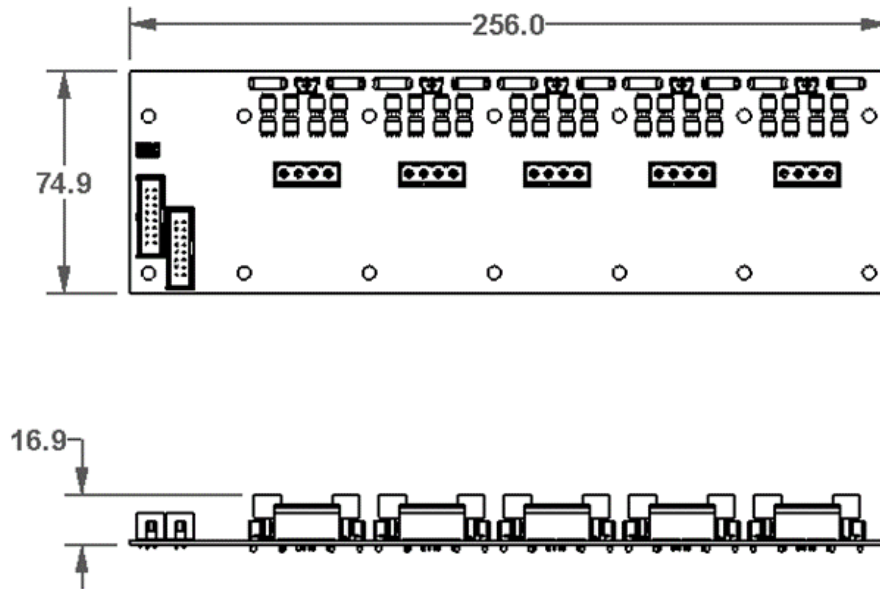

Dimensions for reference only.

Technical Specifications

Specification		Value			
Weight		0.130kg			
Environmental conditions and limits		Same as for track sections--see the SuperTrak GEN3™ Operations and Maintenance Manual at https://supertrakconveyance.com/customer-portal/ for more information.			
Software compatibility		Controller software version between 3.0.6.0 and 3.0.34.x			
Interfaces		<ul style="list-style-type: none"> • 2x Gateway proprietary serial interfaces • 1x JTAG programming interface 			
Power	Parameter	Minimum	Typical	Maximum	Units
	Input DC Voltage - Motor	23	28	31	V
	Motor coil fuse rating	-	-	15	A

This page is intentionally blank.

