

# SuperTrak GEN3™

## Operations and Maintenance Manual

Rev. 9, December 2021



The Foundation of World Leading Automation



# Operation and Maintenance Manual

SuperTrak™ GEN3 Conveyance Platform  
Modular Conveyor

## NOTICES

### COPYRIGHT AND TRADEMARKS

© ATS Automation Tooling Systems Inc. All rights reserved.

ATS™ and, the ATS™ logo, SuperTrak™, TrakMaster™ and other names and logos related to companies, products and services of ATS Automation Tooling Systems Inc. (ATS) and its affiliates are trademarks or service marks of ATS and its affiliates.

Windows® is a registered trademark of Microsoft Corporation, GOO GONE® is a registered trademark of Weiman Products, LLC. Other third-party company and product names mentioned herein may be trademarks of their respective companies.

No license or other right in any trademark, service mark or other intellectual property is granted in this document.

### REFERENCES

References in this document to products or services of third parties and links to third-party websites or information are provided solely as a convenience to you and do not in any way constitute or imply ATS's endorsement, sponsorship, or recommendation of the third party, information, product, or service. ATS is not responsible for the content of any third-party documents or websites and does not make any representation regarding the content or accuracy of such materials. If you decide to use any such third-party materials, or third-party products or services, you do so entirely at your own risk.

### GRAPHICS

All drawings, illustrations, and photographs included in this document are provided to expand and enhance the text. These graphics are representations only and are not necessarily drawn to scale. For accurate drawings, see the *Mechanical Drawing Package* and *Electrical Drawing Package* supplied to you.

### WARRANTY AND LIABILITY

Your warranty and issues related to liability are covered by your contract with ATS or its affiliate. Reference your contract or contact our service department if you have specific questions about your warranty. No additional or other warranties are provided in this document and all warranties and conditions, including, without limitation, implied warranties or conditions of merchantability, or fitness for a particular purpose, or non-infringement, are disclaimed.

While ATS attempts to ensure that all information in this document is accurate and reliable, ATS assumes no obligation to update the content in this document or advise on further developments concerning the subject matter mentioned. ATS does not warrant or make any representation concerning the accuracy or reliability of the content in this document or any documents or websites referenced in this document. The content of documents and websites referenced herein are subject to change without notice. ATS is not responsible for printing or clerical errors.

### CONDITIONS OF ACCEPTABILITY FOR CERTIFICATION

#### Track Module Assembly (Straight & Curved Sections)

- a. Models are evaluated as an integrated component and intended to be a scalable interconnected system provided inline protection fuse(s) are installed on the Bus connection and power supply lines. End user/integrator shall recognize ampacity limits of the bus bar interconnect conductors per the National Electrical Code.
- b. Models are to be powered by a certified SuperTrak motor power supply Assy / 25270337.
- c. Models are evaluated with an optional accessory cable "Control Panel to Section Interconnect" Assy / 25240470 1.2 m, Assy / 125362696 2.0 m or Assy / 25221246 6.5 m (user can adjust the length of the 6.5 m).
- d. The equipment is not evaluated for use in hazardous (classified) environments.
- e. The equipment is not evaluated for use with flammable liquids or materials.
- f. The equipment has been investigated for continuous operation at a maximum operating ambient temperature of 40°C at an altitude up to 2000 m and relative humidity levels from 5-90%, non-condensing.
- g. The equipment has been evaluated for indoor use in pollution degree 2 environments.
- h. The equipment is to be installed by qualified personal in accordance with local and national installation/wiring requirements.
- i. The motor's epoxy resin (potting) is not investigated for flammability (UL94).
- j. Emergency stop, disconnect devices for the SuperTrak system are provided via the mains supply to the SuperTrak motor power supply. Integration and validation of system-wide emergency stops are the responsibility of the end user/integrator.
- k. Functional Safety requirements are the responsibility of the end user/integrator of this component.

#### SuperTrak Motor Power Supply

- a. SuperTrak power supply is evaluated as an integrated component and intended to be a scalable interconnected system provided inline protection fuse(s) are installed on the bus connection and power supply lines. End user/integrator shall recognize ampacity limits of the bus bar interconnect conductors per the National Electrical Code.
- b. A suitable cable is to be provided for the plug/socket component (industrial twist lock) for connecting the mains supply.
- c. SuperTrak motor power supply is for use only with a SuperTrak track module Assy (1060387 or 1060391) & SuperTrak 180 deg. section Assy 1060638.

- d. SuperTrak motor power supply is powered from an ATS SuperTrak conveyance platform control panel Assy / 25202161 or from other appropriate power source with certified (North American listed) overcurrent protection, 10A UL489 breaker, type CC fuses or Type J fuses.
- e. The equipment is not evaluated for use in hazardous (classified) environments.
- f. The equipment is not evaluated for use with flammable liquids or materials.
- g. The equipment has been investigated for continuous operation at a maximum operating ambient temperature of 40°C at an altitude up to 2000 m and relative humidity levels from 5-90%, non-condensing. All permitted mounting orientations. See [Permitted mounting orientations](#) on page 273.
- h. The equipment has been evaluated for indoor use in pollution degree 2 environments.
- i. The equipment is to be installed by qualified personal in accordance with local and national installation/wiring requirements.
- j. Emergency Stop, disconnect devices for the SuperTrak system are provided via the mains supply to the SuperTrak motor power supply. Integration and validation of system-wide emergency stops are the responsibility of the end user/integrator.
- k. Functional Safety requirements are the responsibility of the end user/integrator of this component.

#### SuperTrak GEN3 Conveyor Control Panel

- a. SuperTrak GEN3 conveyor control panel is evaluated as, and is intended only to be used as, an integrated component of the SuperTrak GEN3 conveyor.
- b. SuperTrak GEN3 conveyor control panel is evaluated with scalable supply branches to supply 1 – 12 SuperTrak motor power supplies Assy / 25270337.
- c. The equipment is not evaluated for use in hazardous (classified) environments.
- d. The equipment is not evaluated for use with flammable liquids or materials.
- e. The equipment has been investigated for continuous operation at a maximum operating ambient temperature of 40°C at an altitude of up to 2000 m and relative humidity levels from 5-90%, non-condensing.
- f. The equipment has been evaluated for indoor use in pollution degree 2 environments.
- g. The equipment is to be installed by qualified personal in accordance with local and national installation/wiring requirements. Adequate ground/bond connection is to be provided to the remote connected SuperTrak motor power supplies (<100mohms tested at 10Amps or greater).
- h. Emergency stop, disconnect devices for the SuperTrak system are provided within this control panel. Integration and validation of system-wide emergency stops are the responsibility of the end user/integrator.
- i. Functional safety requirements are the responsibility of the end user/integrator of this component and the integrated system that consists of the ATS SuperTrak conveyance platform system.

#### Model Variations:

Certified models SuperTrak GEN3 track module Assy / 1060387 or 1060391 are also represented as 8FZAM1.0A.A000-1 / SuperTrak straight segment. Models are further supplemented by EN standards as models 25220499.

Certified model SuperTrak GEN3 180 deg section Assy / 1060638 is also represented as 8FZAM2.0A.A000-1 / SuperTrak curve segment.

Certified model SuperTrak motor power supply Assy / 25270337 is also represented as 8FZAP0.00.0100-1 / SuperTrak motor power supply. Modes are further supplemented by EN standards as models 25195828, 25270354.



# Table of Contents

<b>Preface</b> .....	<b>1</b>
Documentation Package .....	1
Official Website .....	1
Style Conventions .....	2
Special Notations .....	2
Frame of Reference .....	3
Referenced Terms .....	4
<b>Safety Information</b> .....	<b>5</b>
Training .....	5
General Safety Rules .....	6
Personal Protective Equipment .....	7
Hazardous Energy .....	8
Electrical .....	8
Mechanical .....	9
Thermal Hazards .....	10
Lockout and Tagout .....	11
Lock Prerequisites .....	11
Tag Prerequisites .....	11
Lockout and Tagout Locations .....	12
Label Descriptions .....	13
Identification Label .....	13
Marking Labels .....	13
Mandatory Action Labels .....	13
Other Labels .....	14
Label Locations .....	16
<b>SuperTrak Conveyance Platform Overview</b> .....	<b>19</b>
Features .....	19
SuperTrak Conveyance Platform Configurations .....	20
SuperTrak Conveyance Platform Components .....	22
Pallet .....	23
Straight Section .....	25
Curved Sections .....	32
Control Panel .....	40
Power Supply .....	42
IR Reader Assembly (Optional) .....	43
IR Reader Mount Assembly (Optional) .....	44
Pallet Setup Tools (Optional) .....	45
Station Setup Tools (Optional) .....	45

<b>Installation</b> .....	<b>47</b>
Prerequisites .....	47
Install the SuperTrak Conveyance Platform .....	48
Install the SuperTrak Conveyance Platform on a SuperTrak GEN3 Frame .....	49
Install the Sections with Custom Stands on a Custom Frame .....	50
Install the SuperTrak Conveyance Platform in an Over/Under Configuration .....	64
Lift a SuperTrak Conveyance Platform Section .....	74
Install a SuperTrak Conveyance Platform Section on a SuperTrak GEN3 Frame .....	81
Install the First SuperTrak Conveyance Platform Section .....	92
Level the Frame .....	95
Connect Two SuperTrak Conveyance Platform Sections Together .....	96
Align the SuperTrak Conveyance Platform Section Joints .....	98
Align the SuperTrak Conveyance Platform Section Heights .....	99
Install a Wedge Adjust .....	100
Fine-Adjust the Upper V-Rail .....	103
Install an IR Reader Mount Assembly .....	110
<b>Controls and Connections</b> .....	<b>113</b>
TrakMaster Software .....	113
Guarding .....	114
Energy Controls .....	115
SuperTrak Conveyance Platform Power Disconnect Switch .....	115
Uninterruptible Power Supply .....	115
Connections .....	116
Straight Section to Straight Section Connections .....	116
Straight Section to 180 Deg. Section Connections .....	116
180 Deg. Section (500 mm) to SuperTrak Control Panel Connection .....	116
Ethernet Port Connection .....	117
Main Power Connection .....	118
Safety Circuit Connection .....	119
PLC Connection .....	120
Ethernet POWERLINK Connection .....	121
Gateway Network Connections .....	122
<b>Operating Procedures</b> .....	<b>129</b>
Pre-Start Inspection .....	130
Pre-Power ON Checks .....	132
SuperTrak Behavior .....	137
SuperTrak Conveyance Platform Power ON Behavior .....	137
SuperTrak Conveyance Platform Power OFF Behavior .....	138
TrakMaster Procedures .....	140
Download TrakMaster .....	140
Login to TrakMaster .....	141
Access the TrakMaster Built-in Help .....	141
Monitor the SuperTrak Conveyance Platform .....	142



<b>Technician Procedures</b>	<b>143</b>
Electrical Procedures	144
Install a Power Supply	145
Replace a Coil Driver Board	150
Replace a Gateway Board	157
Replace an Encoder Assembly	165
Replace a Motor Thermistor	168
Replace the Main Motor Fuse	173
Replace a Coil Fuse	174
Replace an Electrical Interconnect	176
Install an Electrical Interconnect Between a Curved Section and a SuperTrak Control Panel	179
Mechanical Procedures	191
Install a Pallet	191
Remove a Pallet	193
Inspect a Pallet	195
Replace a Pallet Bumper	198
Replace the Pallet Flat Wheels	199
Replace the Pallet V-Wheels	201
Replace a Pallet Magnet Assembly	205
Replace a Pallet Anti-Static Brush	206
Adjust a Pallet Shim	207
Replace a Pallet Lubrication Felt	210
Replace a Pallet Spring	211
Replace a Pallet Encoder Strip Assembly	212
Install a Station Setup Fixture	214
Remove a Station Setup Fixture	214
Align a Pallet Encoder Strip Assembly	215
Replace an Upper V-Rail	230
Replace a Flat Wear Strip	238
Replace a Motor Cover Label	243
Replace a Straight Section	244
Replace a 180 Deg. Section	244
<b>Maintenance</b>	<b>245</b>
Scheduled Maintenance	245
SuperTrak Conveyance Platform Components	245
Electrical Enclosure	246
Cleaning Procedures	247
Clean the SuperTrak Conveyance Platform	247
Clean a Control Panel Air Filter	247
Clean a Pallet Encoder Strip	248
Inspect a Pallet Encoder Strip	248
Replace a Power Supply Filter	249
Lubrication Procedures	250
Lubricate the Pallet Lubrication Felt	250

<b>Troubleshooting</b> .....	<b>251</b>
Communication Faults .....	251
Pre-Power ON Faults .....	252
Power Faults .....	255
Check Coil Resistance to Find Shorted or Mis-wired Coils .....	256
Pallet Faults .....	258
Test Straight Section or Curved Section Hardware .....	259
Test Encoder Functionality .....	259
Test the Coil Functionality .....	260
Test for a Reversed Polarity Coil .....	262
Test the Status of the Hardware .....	265
Test the Rail System .....	266
Test a Magnetic Shunt .....	266
Diagnostic Lights .....	267
Controller Indicator Lights .....	267
Gateway Board (ACB3040) Indicator Lights .....	268
Coil Driver Board (ACB3000) Indicator Lights .....	270
<b>System Specifications</b> .....	<b>271</b>
Performance .....	271
Environment Conditions .....	272
Environmental Limits .....	272
Installation Requirements .....	273
Electrical Services .....	275
Electromagnetic Compatibility (EMC) Requirements for High-Frequency Emis- sions .....	275
Electromagnetic Compatibility (EMC) Requirements for Immunity to Disturbances 276	
<b>Glossary</b> .....	<b>277</b>
<b>SuperTrak Conveyance Platform Service</b> .....	<b>281</b>
Contact ATS .....	281
Return a Part to ATS for Warranty .....	282
Request Service from ATS .....	283
<b>Appendix A: Hardware Torque Specifications</b> .....	<b>285</b>
<b>Appendix B: Spare Parts</b> .....	<b>289</b>
Cables and Wires .....	290
Other Spare Parts .....	293

<b>Appendix C: Component Data Sheets</b> .....	<b>299</b>
Pallet Data Sheet .....	302
Straight Section with FME Data Sheet .....	314
Straight Section with RME Data Sheet .....	317
180 Deg. Section (500 mm) with Standard-Height Stands Data Sheet .....	320
180 Deg. Section (500 mm) with Low-Profile Stands Data Sheet .....	323
180 Deg. Section (800 mm) .....	326
90 Deg. Section .....	329
Control Panel Data Sheet .....	332
Power Supply Data Sheet .....	335
IR Reader Components (Optional) Data Sheet .....	339
Pallet Setup Tools (Optional) Data Sheet .....	341
Pallet Removal Tool (Optional) Data Sheet .....	343
SuperTrak GEN3 Frames .....	344
Interconnect Kit (Straight Section to Straight Section) .....	349
Interconnect (SuperTrak Control Panel to Curved Section) .....	350
<b>Appendix D: Unit Conversions</b> .....	<b>353</b>

This page is intentionally blank.

# Preface

This section provides the following SuperTrak conveyance platform documentation package information:

- *Documentation Package* on page 1
- *Official Website* on page 1
- *Style Conventions* on page 2
- *Special Notations* on page 2
- *Referenced Terms* on page 4

## Documentation Package

ATS supplies the following documentation and software for the SuperTrak conveyance platform:

- SuperTrak™ GEN3 Operation and Maintenance Manual
- TrakMaster™ software (with built-in help)
- Design package, which includes:
  - Electrical drawings
  - Mechanical drawings

## Official Website

The SuperTrak website, [www.supertrakconveyance.com](http://www.supertrakconveyance.com), provides resources such as case studies, certification information, videos, and blog posts.

## Style Conventions





This document uses the following styles to indicate different types of information:

- *Italic text* indicates a document title.
- *Italic text with color* indicates hypertext reference information. For example, a web site link or a link to content within the current document.
- **Bold text** indicates a button or control that requires action during a procedure.
- **Grey Courier text** indicates on-screen messages; for example, a fault or warning message on an HMI screen.
- `Courier text` indicates software code.
- CAPITALIZED TEXT indicates an operational state; for example, ON, OFF, MANUAL mode.
- First Letter Capitalized Text indicates the name of an HMI screen, screen menu, or HMI message.
- Bulleted list indicates items where order is not relevant.
- Numbered list indicates a step-by-step procedure where order is relevant.

## Special Notations

This document uses five (5) levels of notation:

---

 <b>DANGER</b>	Warns that failure to comply results in death or serious injury.
<hr/>	
 <b>WARNING</b>	Warns that failure to comply could result in death or serious injury.
<hr/>	
 <b>CAUTION</b>	Warns that failure to comply could result in minor or moderate injury.
<hr/>	
 <b>NOTICE</b>	Warns that failure to comply may result in property damage.
<hr/>	
	Provides additional information, emphasizes a point, or provides a tip.

---

## Frame of Reference



- The SuperTrak conveyance platform image is for representational purposes only. It may not reflect the system you have installed.
- The direction of travel on each axis (positive or negative) varies based on configuration.

This document describes tooling movement using the following frame of reference:

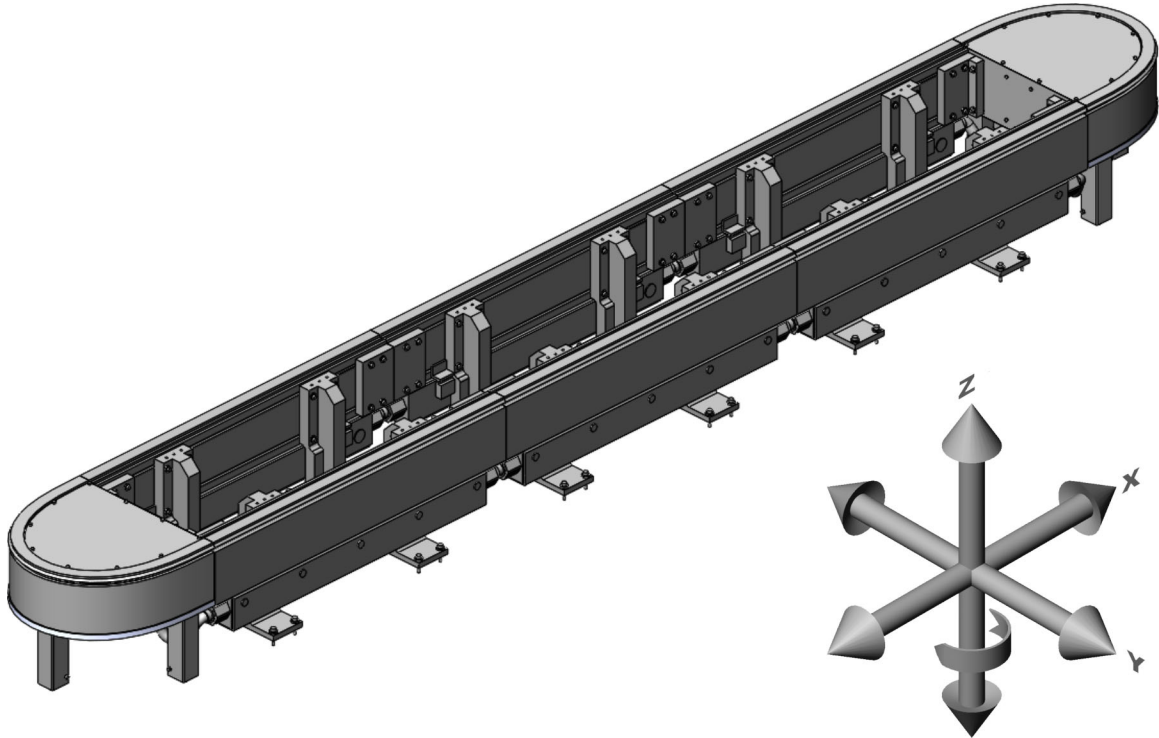

## Referenced Terms

This section defines terms that are used throughout this document.

Term	Description
SuperTrak conveyance platform	Represents the SuperTrak™ GEN3.
TrakMaster	Represents the TrakMaster™ software.
Power supply	Represents the SuperTrak conveyance platform power supply.
Control panel	Represents the SuperTrak conveyance platform control panel.
Pallet	Represents the SuperTrak conveyance platform pallet.
User	Represents all levels of SuperTrak conveyance platform users. It includes operators, maintenance personnel, and technicians.
Operator	Represents a user with basic mechanical knowledge.
Maintenance Personnel	Represents a user with knowledge about routine cleaning, and lubrication procedures. They are expected to complete adjustments that are within validated ranges.
Technician	Represents a user that specializes in a discipline such as electrical, mechanical, or programming. They are expected to complete complex SuperTrak conveyance platform procedures; such as, replacement procedures or adjustments that are outside of validated ranges.

See [Glossary](#) on page 277 for additional definitions.



# Safety Information

This section provides the following important safety information:

- *Training* on page 5
- *General Safety Rules* on page 6
- *Personal Protective Equipment* on page 7
- *Hazardous Energy* on page 8
- *Lockout and Tagout* on page 11
- *Label Descriptions* on page 13
- *Label Locations* on page 16

Read this information thoroughly and completely before operating, or maintaining the SuperTrak conveyance platform.

## Training

SuperTrak conveyance platform training packages are available on request. Contact the ATS Technical Services Department for additional information.

## General Safety Rules

### Everyone:

- Learn how automated equipment works.
- Understand the potential dangers of automated equipment before operating it.
- Energy sources must be shutdown, locked out, and tagged out before preventive maintenance, adjustment, or service.
- Understand and be aware of potential energy sources that exist in the SuperTrak conveyance platform after lockout and tagout (for example; the strong permanent magnets when pallets are removed from the SuperTrak conveyance platform).
- Long hair must be tied up and kept away from SuperTrak conveyance platform devices to prevent entanglement.
- Do not wear loose clothing or dangling jewelry while operating or maintaining the equipment, to prevent entanglement.
- Wear the appropriate personal protective equipment (PPE) for each task.
- Stay away and do not touch any live electrical wires or circuits. Qualified technicians must wear PPE appropriate to the electrical hazard.
- Do not tamper, remove, or make safety controls ineffective.

### Operators:

- Do not remove guarding, covers, or shields. Procedures that involve removing guarding, covers or shields must only be performed by a trained, qualified technician.
- Do not operate damaged equipment. Safety and protection features are impaired in damaged equipment. Turn OFF energy sources immediately. Do not use the automated equipment until a trained, qualified technician confirms it is safe to operate.

### Technicians:

- Do not perform service work alone. Only attempt internal service or adjustments in the presence of a person capable of rendering first aid.
- Read the current *SuperTrak™ GEN3 Operation and Maintenance Manual* before troubleshooting or servicing the equipment.
- Guarding, covers, or shields must not be removed, except for emergency or maintenance purposes.
- If guarding is removed, clearly communicate (for example, with signs or barriers) that the guarding is not functional.
- Guarding around moving devices that has been removed, must be replaced.

- Do not install substitute parts or make any product modifications that are not authorized by ATS because this may introduce new hazards.
- Use insulated tools when working with electrical equipment. Make sure qualified electrical technicians wear appropriate PPE when completing live electrical work according to the hazard assessment.
- Remove electrical power before changing fuses, or use approved fuse-pullers.
- Never use jumper wires or fuse substitutes to replace fuses.
- Replace the line fuses with fuses of the same voltage, current rating, and type. Do not use repaired fuses or short-circuited fuse holders.
- Be prepared to handle electrical fires by keeping dry powder or carbon dioxide extinguishers on hand at all times.
- Verify that all fittings and connections are tight once repair work is complete.
- Do not use compressed air to clean SuperTrak conveyance platform devices. Use clean, lint-free cloths or a vacuum cleaner. Compressed air causes dirt and lubricants to become airborne and contaminate assembly products and tooling.

## Personal Protective Equipment

At a minimum, all users are recommended to wear the following personal protective equipment (PPE) when working with or around the SuperTrak conveyance platform:

- Safety glasses that meet the specific standard requirements the local jurisdiction:
  - North America - ANSI Z87.1
  - Europe - EN 166 F
- Safety shoes that meet the specific standard requirements the local jurisdiction:
  - North America - ASTM F2413
  - Europe - EN ISO 20345 S1

## Hazardous Energy

Any energy source that presents a risk of injury to a person working on equipment is considered a hazardous energy source. The SuperTrak conveyance platform contains the following hazardous energy sources:

- [Electrical](#) on page 8
- [Mechanical](#) on page 9
- [Thermal Hazards](#) on page 10

To prevent accidental or unauthorized start-ups, always lockout and tagout hazardous energy before completing any service or maintenance procedures. Lockout and tagout procedures control hazardous energy supplies, making the SuperTrak conveyance platform inoperable.

See [Lockout and Tagout](#) on page 11.

## Electrical



Servicing an electrical panel that is still connected to its power source may cause injury or death. Unless directed otherwise, turn the **main power disconnect switch** to the OFF position. Lock out and tag out the switch before accessing and servicing the electrical panel. Only qualified electrical technicians should perform service on the electrical panel.

See [Lockout and Tagout](#) on page 11.

The control panel contains high voltages. Electrical hazards may be present from damaged or broken wires, open electrical boxes, or open control panels.

The control panel is designed to be integrated with a main electrical panel, which includes a **main power disconnect switch**. Use the **main power disconnect switch** to turn OFF SuperTrak conveyance platform power, but maintain UPS power in the control panel. Use the **SuperTrak conveyance platform power disconnect switch** to isolate the SuperTrak conveyance platform power and turn the UPS OFF. If an electrical hazard occurs:

1. Stop the SuperTrak conveyance platform.
2. Turn the **main power disconnect switch** to the OFF position.
3. Turn the **SuperTrak conveyance platform power disconnect switch** to the OFF position.
4. Allow stored energy of the UPS to discharge until the LED indicator of the UPS is not illuminated.

Do not turn ON power to the SuperTrak conveyance platform until an electrical technician has corrected the situation.

See [Energy Controls](#) on page 115.

## Mechanical

 **WARNING**

Servicing mechanical components or devices while still connected to energy sources may cause injury. As required for access and service of the mechanical component, open the safety circuit or turn the **main power disconnect switch** to the OFF position and lock out and tag out the **main power disconnect switch**. Only qualified technicians should access mechanical components or devices.

Understand and be aware of stored energy sources (for example; stored electrical energy, or strong magnetic field) that exist in the SuperTrak conveyance platform after lockout and tagout.

See [Lockout and Tagout](#) on page 11.

 **CAUTION**

- The magnetic field generated by the pallets can be harmful to pacemaker wearers. Maintain a minimum distance of 31 cm (12 in.) between the pallet and the implant location. The permanent magnets in the pallets have a strong magnetic field. When the pallets are installed on the SuperTrak conveyance platform, the magnetic field around the pallet is low. When a pallet is removed from the SuperTrak conveyance platform, the permanent magnets are exposed and the magnetic field is very strong.
- Always install a keeper plate on the pallet magnet when a pallet is removed from the SuperTrak conveyance platform to reduce the magnetic field to a safe level.
- The magnetic field of the SuperTrak conveyance platform may induce magnetic materials into motion, creating potential projectiles or pinch points. Various electronic equipment and magnetic data carriers can also be affected by magnetic fields.

The SuperTrak conveyance platform has mechanical hazards from moving tooling components or devices. Crushing, pinching, and impact injuries can result from devices actuated by potential or kinetic energy in the form of rotational, linear force, or gravity.

The magnetic field generated by the pallets can be harmful to pacemaker wearers. Maintain a minimum distance of 31 cm (12 in.) between the pallet and the implant location. The permanent magnets in the pallets have a strong magnetic field. When the pallets are installed on the SuperTrak conveyance platform, the magnetic field around the pallet is low. When a pallet is removed from the SuperTrak conveyance platform, the permanent magnets are exposed and the magnetic field is very strong.

The magnetic field of the SuperTrak conveyance platform may induce magnetic materials into motion, creating potential projectiles or pinch points. Various electronic equipment and magnetic data carriers can also be affected by magnetic fields.

In the event of a mechanical hazard, turn the **main power disconnect switch** to the OFF position. Do not turn ON power to the SuperTrak conveyance platform until a qualified technician has corrected the situation.

## Thermal Hazards

**WARNING**

Allow adequate time for hot surfaces to cool before commencing work. Wear the appropriate PPE when working on or near the thermal hazard. Use a non-contact thermometer to verify the temperature.

**NOTICE**

The lifespan of some SuperTrak components may be compromised when temperature-related TrakMaster configuration parameters are adjusted from the default value.

For optimum lifespan of SuperTrak conveyance platform components, do not increase the default value of the electronics temperature configuration parameter, and use caution when increasing the coil temperature configuration parameter:

- Coil Temperature Limit (°C); default=60, hard limit=90.
- Electronics Temperature Limit (°C); default=60, hard limit=70.

The SuperTrak conveyance platform may include thermal hazards if temperature-related TrakMaster configuration parameters are adjusted from the default value.

Thermal hazards include any excessively hot or cold point of contact. Thermal hazards can cause contact injuries to exposed skin, or create a fire hazard. Use shielding to avoid contact burns. Dissipate thermal to make sure the point of contact is at a moderate temperature before working near it.

See [Access the TrakMaster Built-in Help](#) on page 141 to access the TrakMaster built-in help for more information about configuration parameters.

## Lockout and Tagout



Understand and be aware of stored energy sources (for example; uninterrupted power supply (UPS) energy, or magnetism) that exist in the SuperTrak conveyance platform after lockout and tagout.

See [Hazardous Energy](#) on page 8.



This lockout and tagout information is provided for reference only. Follow the lockout and tagout procedures listed below or use an applicable lockout tagout procedure that complies with local requirements.

Lockout and tagout neutralizes all sources of SuperTrak conveyance platform energy, making it inoperable and preventing accidental or unauthorized energizing of the SuperTrak conveyance platform. Follow an approved lockout and tagout procedure before maintenance or service, or where unexpected SuperTrak conveyance platform startup or the release of stored energy may cause injury.

## Lock Prerequisites

An acceptable lock should:

- Be provided by an employer. Ensure standardization (size, shape and color) and purchase from a reputable manufacturer.
- Be able to withstand heat, cold, and humidity.
- Be strong enough that it cannot be removed with heavy force.
- Not be a combination lock.
- Have only one (1) key and are not able to be opened using any other key.

## Tag Prerequisites



A tag must never be used as a substitute for a lock. A tag is a visual warning that does not provide physical protection.

A good tag should:

- Have a clear warning.
- Be easy to read (that is; legible and understandable).
- Have the identification mark of the person who applied it.
- Be secure enough to prevent accidental removal, and durable enough to withstand extreme temperatures, fumes, and caustic chemicals.
- Be secured with something similar to a nylon cable tie that is self-locking, can be attached by hand, can resist release with less than 23 kgs (50 lbs) of pressure, and cannot be reused.

## Lockout and Tagout Locations

The control panel is designed to be integrated with a main electrical panel that includes a main power disconnect switch.

To lock out SuperTrak conveyance platform hazardous energy, complete one (1) of the following:

- Lockout and tagout the **main power disconnect** switch when the SuperTrak conveyance platform power must be OFF, but the SuperTrak conveyance platform UPS power can be ON.
- Lockout and tagout the **main power disconnect** switch and the **SuperTrak conveyance platform power disconnect** switch when SuperTrak conveyance platform power and UPS power must be OFF.

See [SuperTrak Conveyance Platform Power Disconnect Switch](#) on page 115, [SuperTrak Conveyance Platform Power ON Behavior](#) on page 137, and [SuperTrak Conveyance Platform Power OFF Behavior](#) on page 139.



## Label Descriptions

Labels are applied throughout the SuperTrak conveyance platform to warn users of possible or certain hazards. Read this section carefully and comply with the required actions, warnings, or prohibitions.

### Identification Label



An electrical nameplate is located on the door of the control panel. It specifies the SuperTrak conveyance platform power requirements and provides the electrical drawing reference number (25202161).

Maintain correct SuperTrak conveyance platform power requirements. If power levels fall below or rise above the requirements specified on the identification label, the SuperTrak conveyance platform will not work properly and damage may occur.









### Marking Labels

Label	Label Name	Description
	Ground	This label is affixed next to grounded connections. The grounding conductor is the current path that enables protective devices, such as circuit breakers and fuses to operate when a fault occurs.

### Mandatory Action Labels

Label	Label Name	Description
	Read and Understand the Manual	Users should read the Operation and Maintenance Manual before operating the SuperTrak conveyance platform. Technicians should read and understand the Operation and Maintenance Manual before conducting any work or service in the referenced area. Personal injury may occur if the label warning is not observed. Label number: 6017X-ISO.
	Mandatory Lockout and Tagout	Personal injury may occur if the label warning is not observed. See <a href="#">Lockout and Tagout</a> on page 11. Label number: 6013X-ISO.

## Other Labels

Label	Label Name	Description
 <p><b>DANGER</b></p>  <p>Arc flash and shock hazard. Follow ALL requirements in NFPA 70E for safe work practices and for Personal Protective Equipment.</p>  <p><b>DANGER</b></p> <p>Risque de coup d'arc et de décharge électrique. Observer TOUTES les exigences de la norme NFPA 70E concernant les pratiques de travail sécuritaires et l'équipement de protection personnelle.</p>  <p><b>GEFAHR</b></p> <p>Gefahr einer Bogenfunkenbildung oder eines elektrischen Schlags! ALLEN Anforderungen in NFPA 70E in Bezug auf sichere Arbeitspraktiken und persönliche Schutzausrüstung Folge leisten.</p>	<p>Danger - Arc Flash and Shock</p>	<p>This label warns users of arc flash and shock hazard. Follow ALL requirements in NFPA 70E for safe work practices and for Personal Protective Equipment. Label number: C459-53.</p>
 <p><b>WARNING</b></p>  <p>UPS VOLTAGE PRESENT WHEN POWER IS OFF. Contact may cause electric shock or burn. Turn off and lock out UPS output power before servicing.</p>  <p><b>AVERTISSEMENT</b></p> <p>TENSION D'ONDULEUR PRÉSENTE LORSQUE L'ALIMENTATION EST COUPÉE. Le contact peut provoquer un choc électrique ou une brûlure. Sectionner et verrouiller la sortie électrique de l'onduleur avant toute intervention.</p>  <p><b>WARNUNG</b></p> <p>Auch bei ausgeschalteten Hauptschalter unter Spannung. Bei Kontakt elektrischer Schock oder Verbrennungen möglich. Ausschalten und Abstecken der Spannungszufuhr bevor Service durchgeführt wird.</p>	<p>Warning - UPS Voltage Present</p>	<p>This label warns users that UPS voltage is present when power is OFF. Contact may cause electric shock or burn. Turn OFF and lock out UPS output power before servicing. Label number: C459-54.</p>

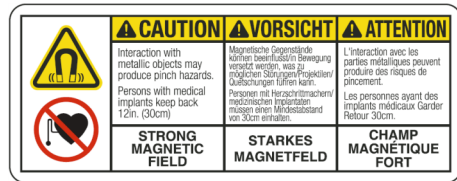
Label	Label Name	Description
 <p><b>WARNING</b></p> <p>Hazardous voltage. Power shall be disconnected before enclosure is opened. Enclosure shall be closed before power is restored.</p> <p><b>AVERTISSEMENT</b></p> <p>Tension dangereuse. L'alimentation électrique doit être débranchée avant d'ouvrir l'enceinte. L'enceinte doit être fermée avant de rétablir l'alimentation électrique.</p> <p><b>WARNUNG</b></p> <p>Gefährliche Spannung! - Gerät bzw. Anlage vor dem Öffnen des Gehäuses spannungsfrei schalten. - Die Anlage gegen unbeabsichtigtes Wiedereinschalten sichern. - Vor dem Wiedereinschalten Gehäuse vorschriftsmäßig verschließen.</p>	<p>Warning - Hazardous Voltage</p>	<p>This label warns users of electrical energy. Only qualified electrical technicians should complete work in these areas. Disconnect power before opening the electrical cabinet working within. Close the electrical cabinet before turning the power ON. Label number: C459-49.</p>
 <p><b>CAUTION</b> Interaction with metallic objects may produce pinch hazards. Persons with medical implants keep back 12in. (30cm)</p> <p><b>VORSICHT</b> Magnetische Gegenstände können durch statische Bewegung angezogen werden, was zu möglichen Stürzen/Projektilen/Auswirkungen führen kann. Personen mit Herzschrittmachern/medizinischen Implantaten müssen einen Mindestabstand von 30cm einhalten.</p> <p><b>ATTENTION</b> L'interaction avec les parties métalliques peuvent produire des risques de pincement. Les personnes ayant des implants médicaux Garder Retour 30cm</p> <p><b>STRONG MAGNETIC FIELD</b>    <b>STARKES MAGNETFELD</b>    <b>CHAMP MAGNÉTIQUE FORT</b></p>	<p>Caution - Strong Magnetic Field</p>	<p>This label warns users of a strong magnetic field. Interaction with metallic objects may produce pinch hazards. Persons with medical implants must keep back 30 cm (12 in.). Label number: 125309778.</p>

## Label Locations

This section describes the location of the safety labels on the SuperTrak conveyance platform.

### Pallet Label

The pallet has the following label:

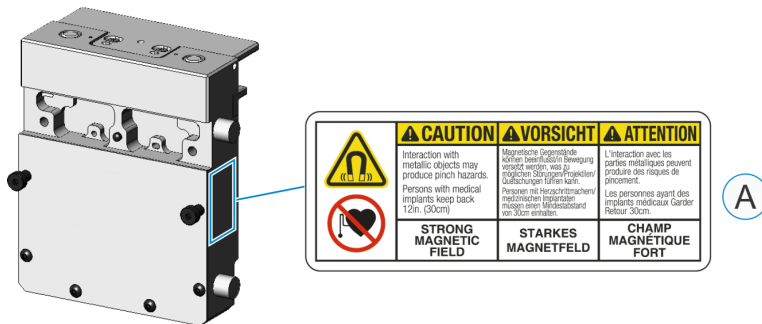

ID	Label	Location
A	Caution - Strong Magnetic Field Label number: 125309778. See <a href="#">Other Labels</a> on page 14.	Side of each pallet.

### Power Supply Label

This power supply has the following label:

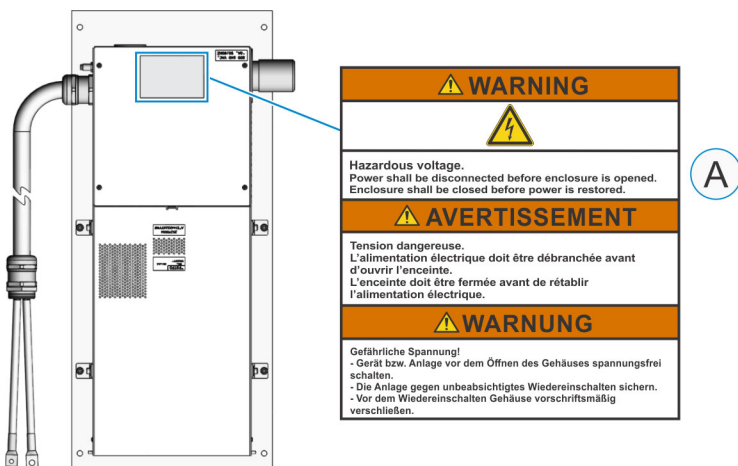

ID	Label	Location
A	Warning - Hazardous voltage. Label number: C459-49. See <a href="#">Other Labels</a> on page 14.	Side of each pallet.

**Control Panel Labels**

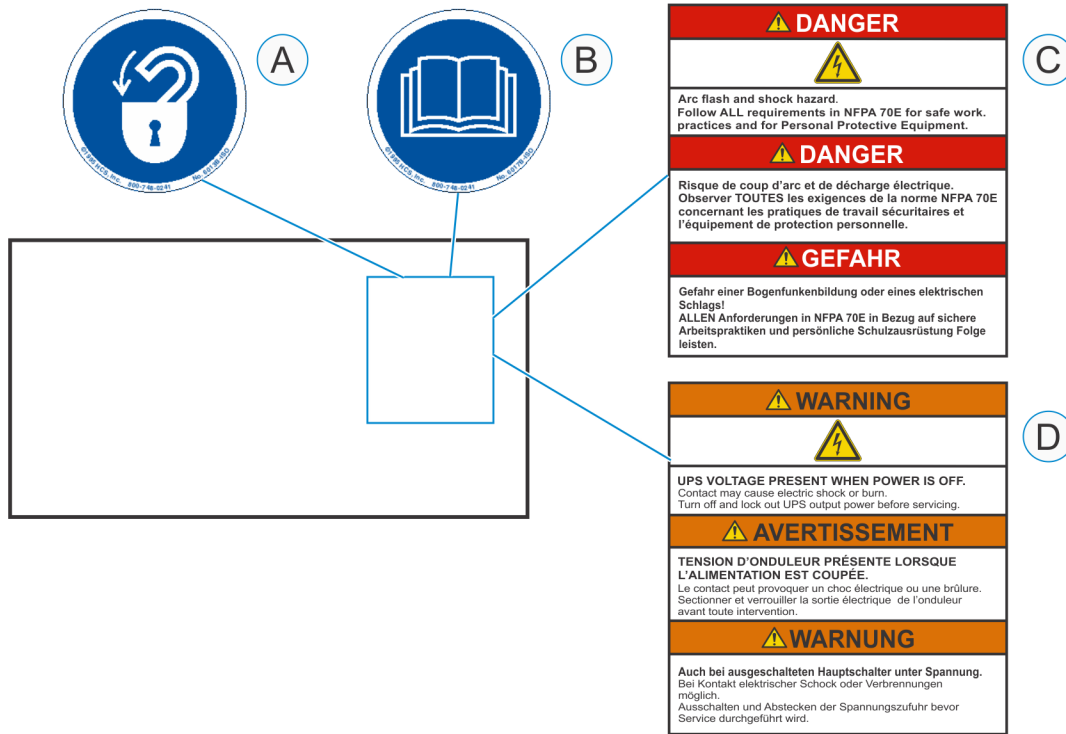

ID	Label	Location
A	Mandatory Lockout and Tagout Label number: 6013X-ISO. See <a href="#">Mandatory Action Labels</a> on page 13.	Outside door of the control panel.
B	Read and Understand the Manual Label number: 6017X-ISO. See <a href="#">Mandatory Action Labels</a> on page 13.	
C	Danger - Arc Flash and Shock Hazard Label number: C459-53. See <a href="#">Other Labels</a> on page 14.	
D	Warning - UPS Voltage Present Label number: C459-54. See <a href="#">Other Labels</a> on page 14.	

This page is intentionally blank.

# SuperTrak Conveyance Platform Overview

The SuperTrak conveyance platform is a high-speed pallet transport system. It allows the direction, acceleration, speed, and position of each pallet to be individually programmed. Integrated collision avoidance eliminates pallet-to-pallet contact and provides auto-queuing at process stations.

This section provides the following overview information about the SuperTrak conveyance platform:

- [Features](#) on page 19
- [SuperTrak Conveyance Platform Configurations](#) on page 20
- [SuperTrak Conveyance Platform Components](#) on page 22

## Features

Some features of the SuperTrak conveyance platform include:

- Integration flexibility: works with any programmable logic controller (PLC)
- Fast indexing: maximum speed of 4 m/s (13.1 ft./s)
- Acceleration: 4G for a 1 kg (2.2 lb) payload, 1G for a 10 kg (22 lb) payload
- Precision pallet control: stop repeatability of  $\pm 0.01$  mm (0.00039 in.)
- High payload: each pallet can hold 10+ kg (22+ lb)<sup>1</sup>
- Scalable: modular system provides design flexibility
- Sealed system: resistant against debris from harsh environments and liquid-sealed
- Low maintenance: has few moving parts

See [System Specifications](#) on page 271 for a complete list of SuperTrak conveyance platform specifications.

---

1. Higher payloads are possible. Contact ATS with application details.

## SuperTrak Conveyance Platform Configurations

The standard SuperTrak conveyance platform is available in modular sections, to allow for various SuperTrak conveyance platform configurations.

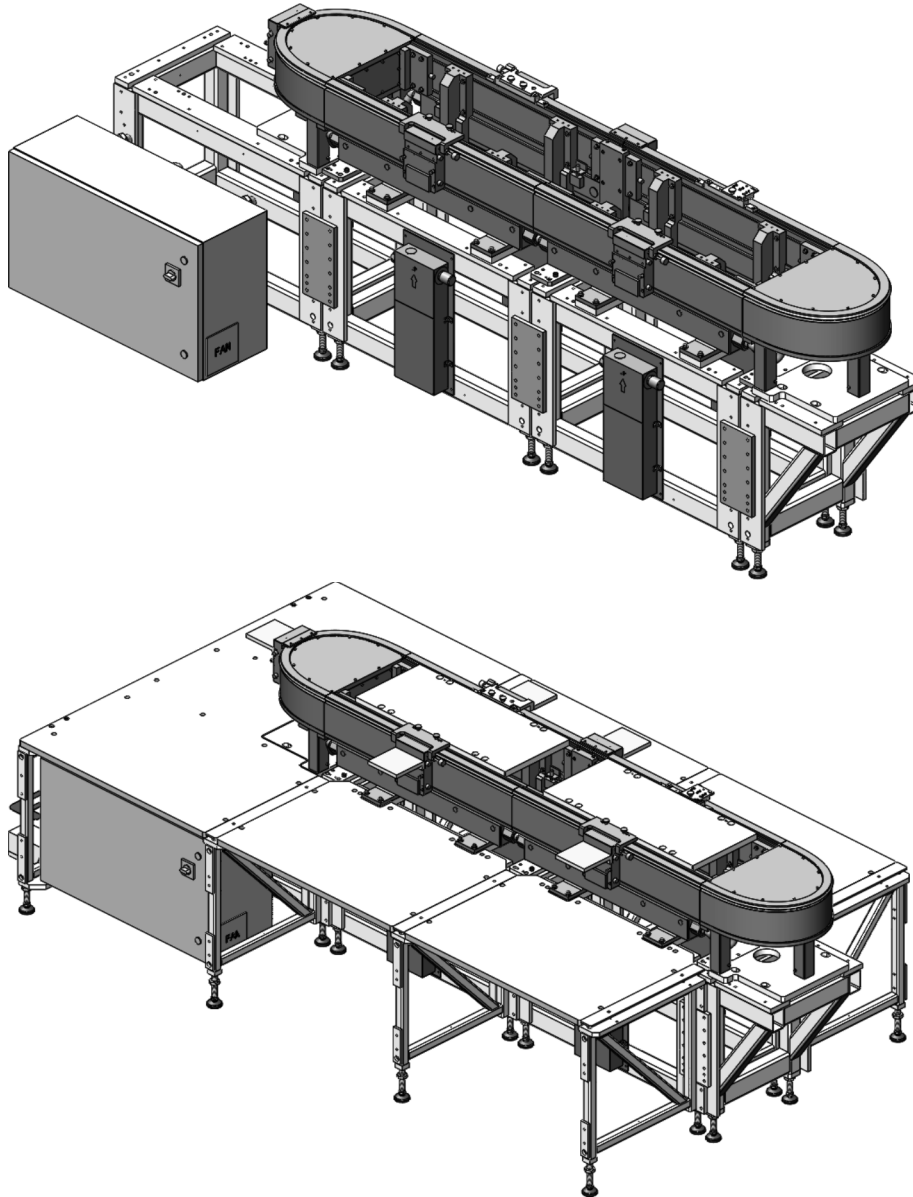

See [Appendix C: Component Data Sheets](#) on page 299 for additional information about the modular SuperTrak conveyance platform components.



The SuperTrak conveyance platform can be configured of sections with low-profile stands in a horizontal or vertical (also known as over/under) configuration. For this method, the SuperTrak conveyance platform is mounted on a plate.

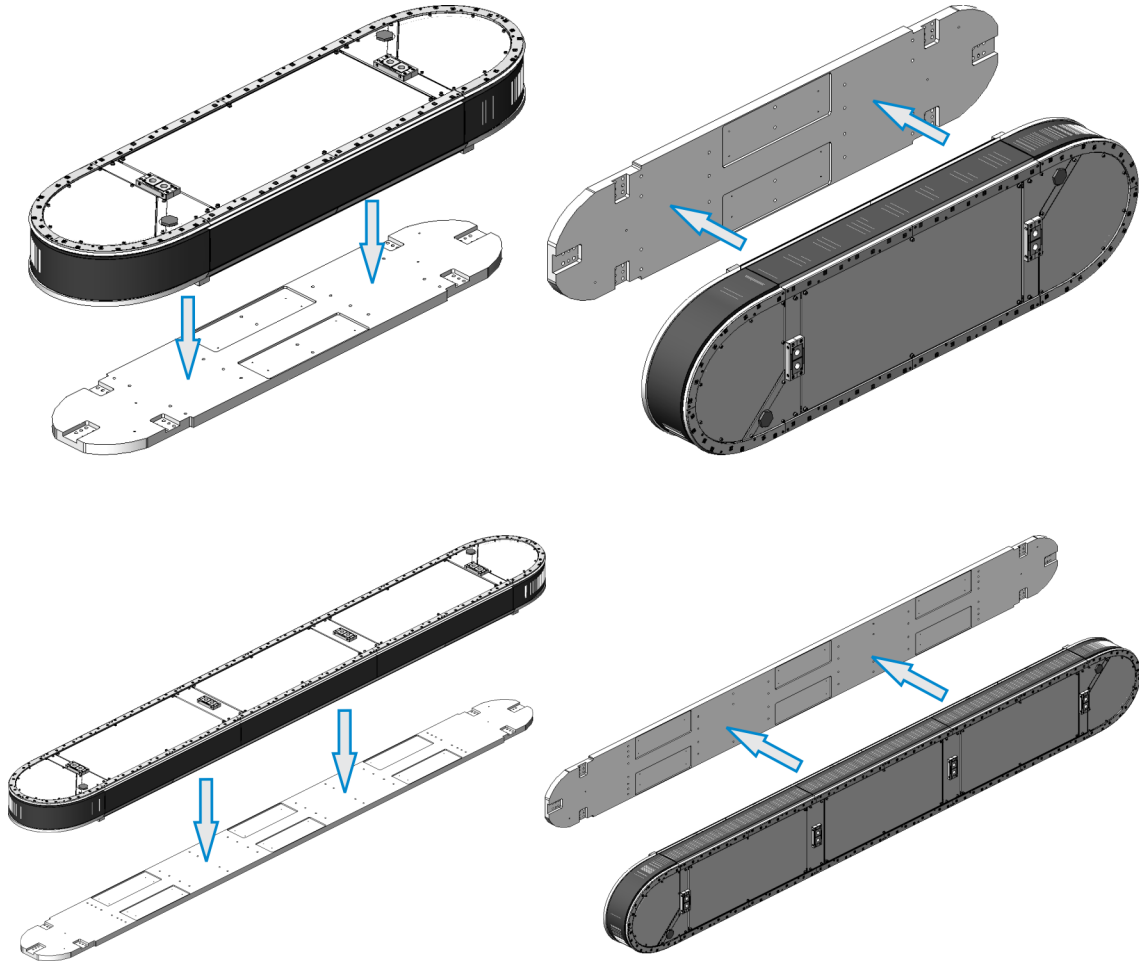

See [Straight Section with RME Data Sheet](#) on page 317, and [180 Deg. Section \(500 mm\) with Low-Profile Stands Data Sheet](#) on page 323 for additional information about these SuperTrak conveyance platform sections.

# SuperTrak Conveyance Platform Components

SuperTrak conveyance platform components are configured, based on the required application. This illustration provides an example of one configuration. It describes the components that a typical SuperTrak conveyance platform includes.

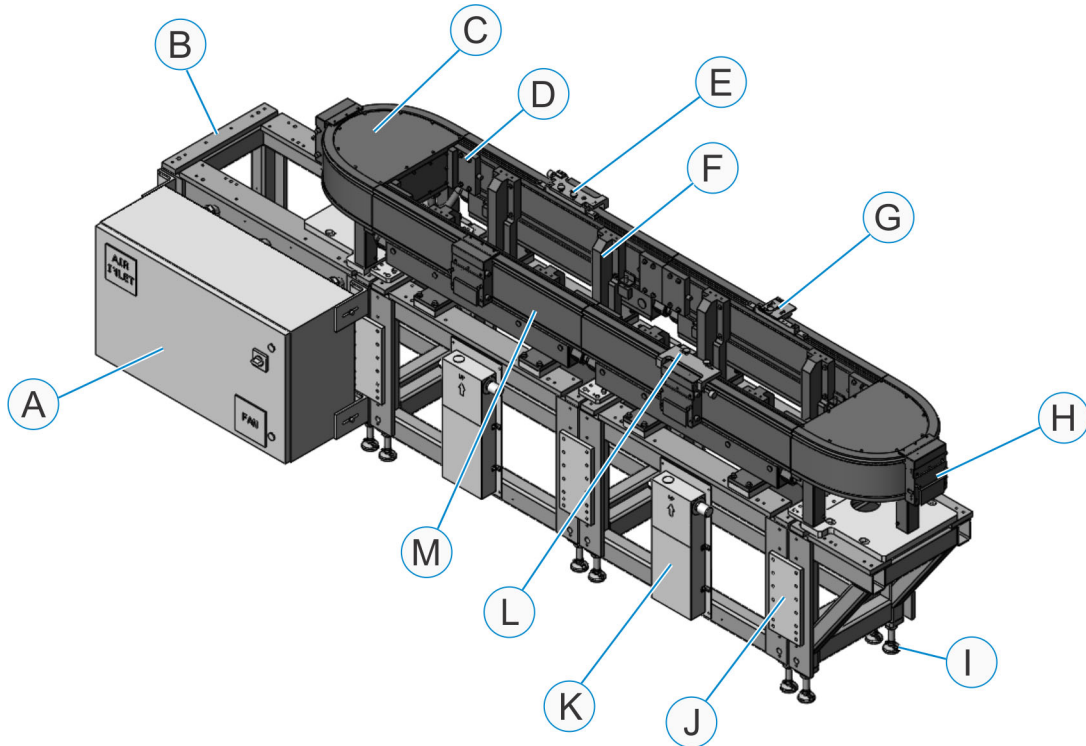

<b>A</b>	Control panel See <a href="#">Encoder Assemblies</a> on page 38.	<b>G</b>	Pallet setup adjustable chip finder
<b>B</b>	SuperTrak GEN3 frame	<b>H</b>	Pallet (may also be referred to as a "shuttle") See <a href="#">Pallet</a> on page 23.
<b>C</b>	Curved section (180 deg. 500 mm in this illustration) See <a href="#">Curved Sections</a> on page 32.	<b>I</b>	Leveling foot
<b>D</b>	Wedge adjust	<b>J</b>	Connection plate
<b>E</b>	Pallet setup removable locate	<b>K</b>	Power supply See <a href="#">Power Supply</a> on page 42.
<b>F</b>	Stand with height adjustment	<b>L</b>	Station setup tool See <a href="#">Station Setup Tools (Optional)</a> on page 45.
		<b>M</b>	Straight section See <a href="#">Straight Section</a> on page 25.

## Pallet

The pallet provides a transport platform for carrying production parts along a SuperTrak conveyance platform. The pallet shelf (not included) is customized for the customer product. A pallet may also be referred to as a “shuttle.”

See [Pallet Data Sheet](#) on page 302 for additional information.

### Pallet - Front View

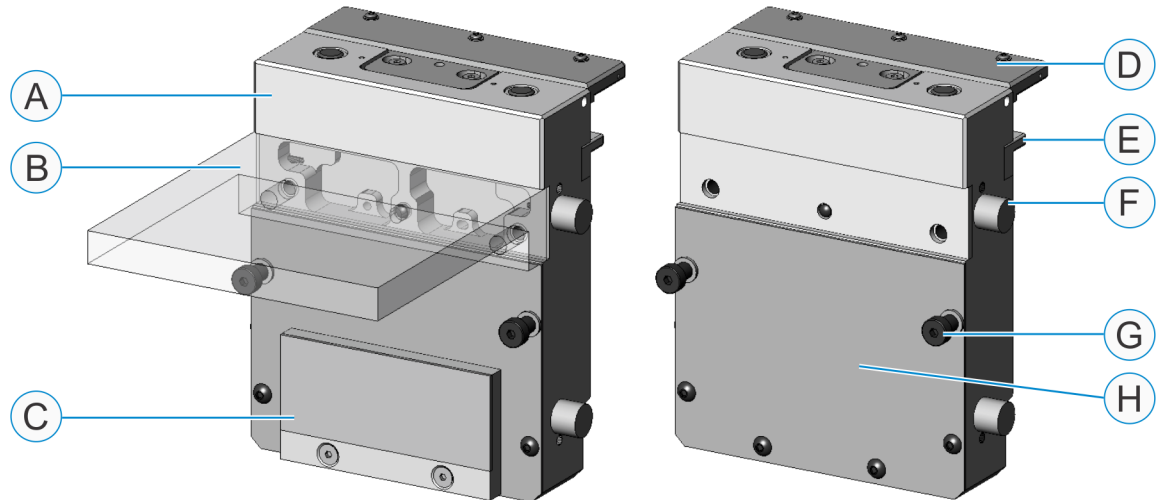

ID	Component Name	Description
<b>A</b>	Pallet base	The main body of the pallet.
<b>B</b>	Pallet shelf (not included)	Carries the customer product from station to station. The pallet shelf is customer-specific. The illustration is provided for reference only.
<b>C</b>	IR tag (optional)	Provides a unique pallet number for each pallet for fixture tracking.
<b>D</b>	Pallet encoder strip assembly	Contains the encoder strip.
<b>E</b>	Anti-tip block (1 of 2)	Protects the pallet during unexpected impact and contains the anti-static brush.
<b>F</b>	Bumper	Provides cushion to the pallet when pallets are manually moved. Bumpers can be modified or extended to accommodate wider pallet shelves.
<b>G</b>	Shoulder screws (1 of 2)	Provides pallet removal tool connection points, which are used during pallet installation and removal.
<b>H</b>	Front cover plate	Provides access to the magnet assembly screws.

Pallet - Back View

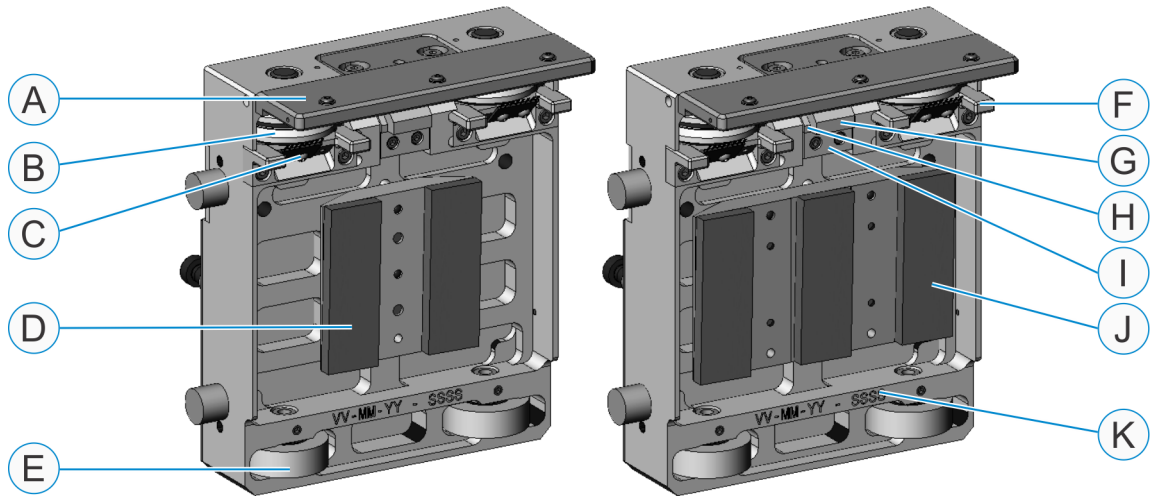

ID	Component Name	Description
A	Pallet encoder strip assembly	Contains the encoder strip.
B	V-wheel (1 of 2)	Travels on the upper v-rail of the section.
C	Anti-static brush (1 of 2)	Dissipates static that is created during pallet motion.
D	2-Magnet assembly	Supports the pallet against the upper v-rail, and generates the forces needed to control pallet motion. All pallets on the SuperTrak conveyance platform are either 2-magnet or 3-magnet.
E	Flat wheel (1 of 2)	Travels on the flat wear strip of the section.
F	Anti-tip block (1 of 2)	Protects the pallet during unexpected impact and keeps the pallet on the SuperTrak conveyance platform when unplanned Z-axis forces are applied to the pallet. It contains the anti-static brush.
G	Lubrication felt	Lubricates the upper v-rail.
H	Lubrication holder	Contains the spring-loaded lubrication felt.
I	Lubrication locking block	Secures the lubrication holder.
J	3-Magnet assembly	Supports the pallet against the upper v-rail, and generates the forces needed to control pallet motion. All pallets on the SuperTrak conveyance platform are either 2-magnet or 3-magnet.
K	Serial number	Provides the serial number of the pallet.

## Straight Section

Straight sections are connected in series to create a path for pallets to travel on.

### Straight Section Power Options



If a pallet moving at high speed transfers from a standard straight section to a low power straight section, the electro-magnetic field aggressively stops the pallet, even when there is no power.

In a typical SuperTrak conveyance platform all straight sections are standard. In applications where operators need to interact directly with a pallet, one or more adjacent straight sections can be low power. The following table summarizes the features of each type of straight section:

Feature	Standard Straight Section	Low Power Straight Section
Benefits	Provides fast, high-precision part handling.	Allows for applications to be designed that allow operators to interact directly with a pallet.
Input voltage	28VDC	15VDC
Maximum acceleration	4g for a 1 kg (2.2 lb) payload, 1g for a 10 kg (22 lb) payload	0.1g for a 10 kg (22 lb) payload
Maximum velocity	4 m/s (13.1 ft./s)	0.15 m/s (0.49 ft./s)

### Straight Section Electronics Options

Straight sections are available with the electronics panel at the front or rear:

- Front mounted electronics (FME)
- Rear mounted electronics (RME)

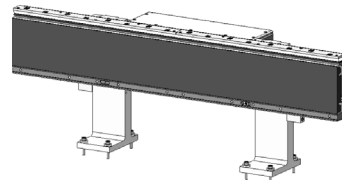
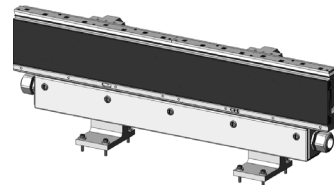

See [Straight Section with FME Data Sheet](#) on page 314, and [Straight Section with RME Data Sheet](#) on page 317 for additional information.

**Straight Section - Electrical Door Closed**

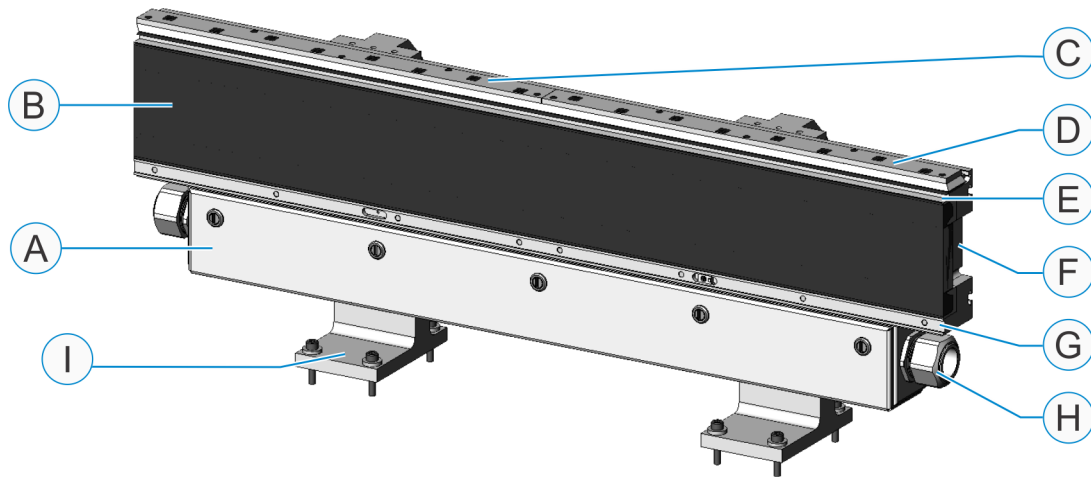

ID	Component Name	Description
A	Electrical door (closed)	Encloses the electrical components. Straight sections are available with front mounted electronics (FME) as shown, or rear mounted electronics (RME).
B	Linear motor	Produces the electromagnetic force that propels the pallets. The linear motor includes: <ul style="list-style-type: none"> <li>• 20 potted coils.</li> <li>• An iron core lamination assembly.</li> </ul> See <a href="#">Coils</a> on page 39 for information about coil numbering.
C	Left encoder assembly	Measures the pallet position using encoder read heads. See <a href="#">Encoder Assemblies</a> on page 38 for information about encoder numbering.
D	Right encoder assembly	
E	Upper v-rail	Provides a track for the pallet V-wheels to travel on.
F	Track structure	Aluminum structure that forms the base of a track. All other track module components are mounted to the track structure.
G	Flat wear strip location	Provides a smooth surface for the pallet flat wheels to travel on.
H	Electrical interconnect	Connector for conduit that contains the power and network cables. See <a href="#">Interconnect Kit (Straight Section to Straight Section)</a> on page 349.
I	Stand (1 of 2)	Mounts the section to the SuperTrak conveyance platform frame. Straight sections are available with standard-height stands as shown, or low-profile stands.

### Straight Section - Electrical Door Open



- The coil driver boards in the low power straight section are visually identical to the coil driver boards in the high power straight section, but they are different.
- The left coil driver board and the right coil driver board are the same. The connections to the gateway boards are different, so they are referenced as the “left” or “right” coil driver board.

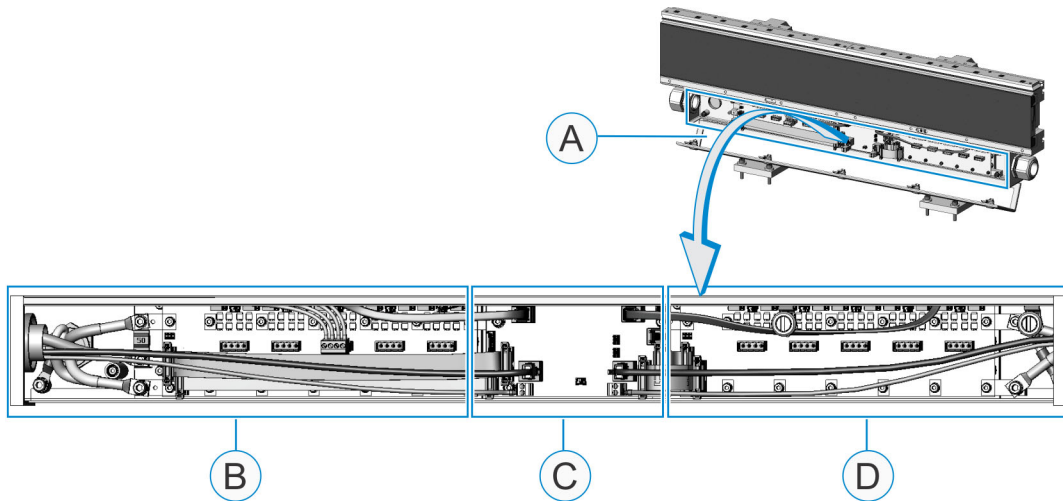

ID	Assembly Name	Description
A	Electrical door (open)	Provides access to the straight section circuit boards.
B	Left coil driver board	See <a href="#">Straight Section - Left Coil Driver Board</a> on page 28, or <a href="#">Left Coil Driver Board with a Power Supply Connected</a> on page 29.
C	Gateway board	See <a href="#">Gateway Board</a> on page 30.
D	Right coil driver board	See <a href="#">Right Coil Driver Board</a> on page 31.

### Straight Section - Left Coil Driver Board

**NOTICE**

If the SuperTrak conveyance platform is programmed with more than one safety circuit (different guard zones), remove the 28VDC motor power connection from the zone boundaries.

See the *SuperTrak Conveyance Platform Electrical Drawings* for additional information.



The left coil driver board and the right coil driver board are the same. The connections to the gateway boards are different, so they are referenced as the "left" or "right" coil driver board.

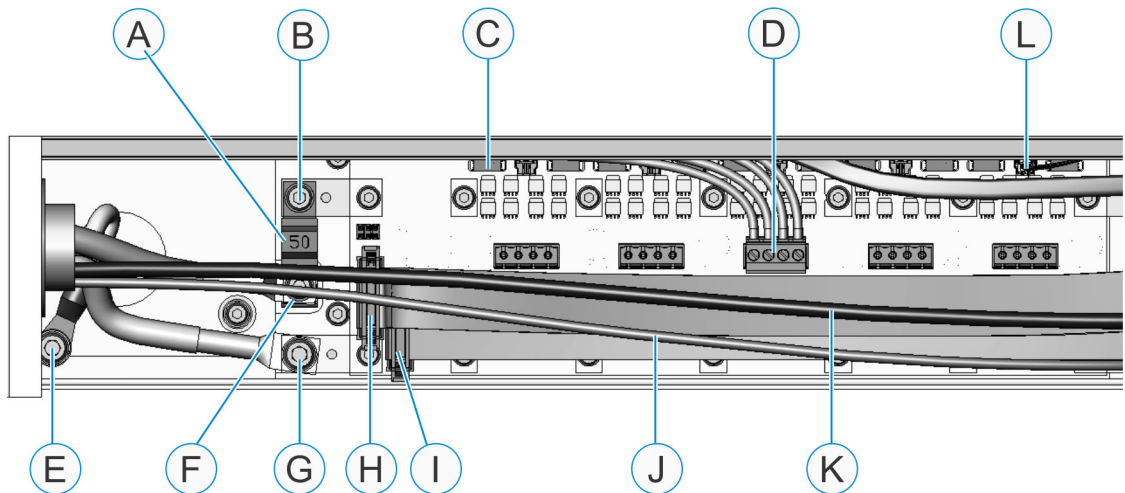

<b>A</b>	50A fuse <sup>a</sup>	<b>G</b>	Common connection
<b>B</b>	Motor power connection for a power supply	<b>H</b>	Ribbon cable connection - connects to the far left of the coil driver board
<b>C</b>	Coil fuse (1 of 10; one for each coil)	<b>I</b>	Ribbon cable connection - connects to the inner-left of the coil driver board
<b>D</b>	Coil connection <sup>b</sup> (1 of 5; two coils for each connection)	<b>J</b>	24V digital power cable (battery backup)
<b>E</b>	Frame ground connection	<b>K</b>	Gateway network cable
<b>F</b>	Motor power connection <sup>c</sup>	<b>L</b>	Thermistor connector (1 of 5)

a. See [Replace the Main Motor Fuse](#) on page 173.

b. The coil wires on the high power section are of larger gauge than the coil wires on the low power section.

c. The motor power connection is 28VDC between two (2) high power sections, and 15VDC between two (2) low power sections. There is no motor power connection between a high power section and a low power section.



### Left Coil Driver Board with a Power Supply Connected

**NOTICE**

If the SuperTrak conveyance platform is programmed with more than one safety circuit (different guard zones), remove the 28VDC motor power connection from the zone boundaries.

See the *SuperTrak Conveyance Platform Electrical Drawings* for additional information.



The left coil driver board and the right coil driver board are the same. The connections to the gateway boards are different, so they are referenced as the "left" or "right" coil driver board.

This drawing indicates the connections that are different on the left coil driver board when a power supply is connected.

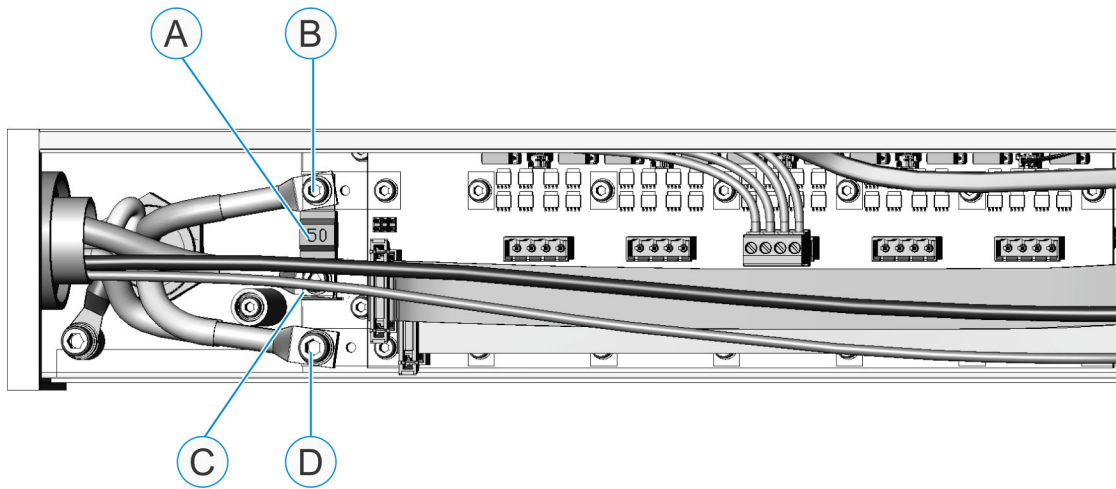

<b>A</b>	50A fuse <sup>a</sup>	<b>C</b>	Motor power connection <sup>b</sup>
<b>B</b>	Power supply connection: 28VDC for standard straight section, or 15VDC for a low power straight section	<b>D</b>	Common connection

a. See [Replace the Main Motor Fuse](#) on page 173.

b. The motor power connection is 28VDC between two (2) high power sections, and 15VDC between two (2) low power sections. There is no motor power connection between a high power section and a low power section.

Gateway Board

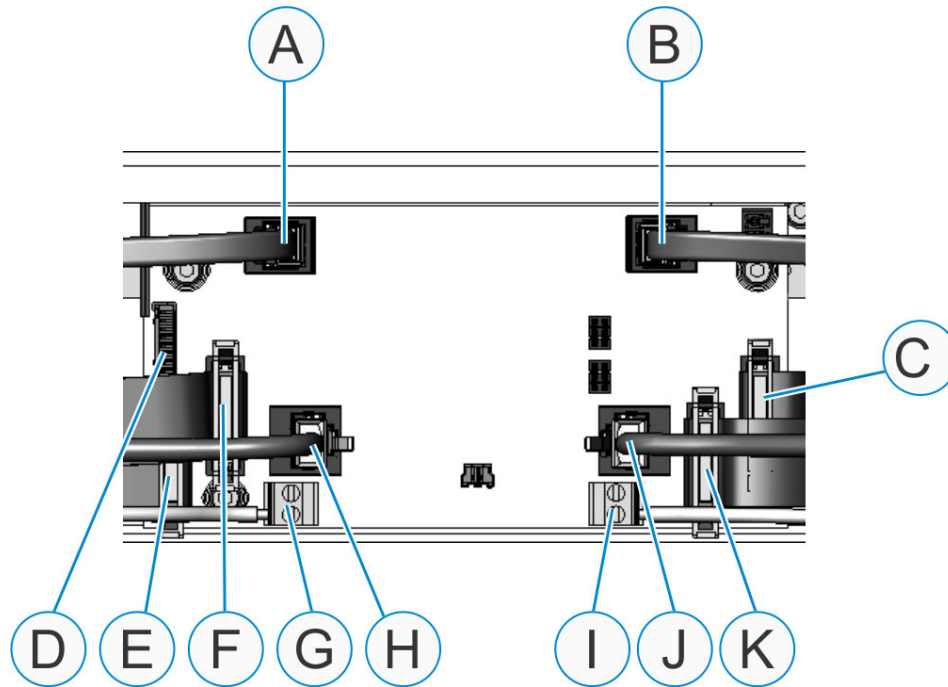

<b>A</b>	Left encoder cable port	<b>G</b>	24V digital power connection
<b>B</b>	Right encoder cable port	<b>H</b>	Gateway network port
<b>C</b>	Ribbon cable connection - connects to the top-right of the coil driver board	<b>I</b>	24V digital power connection
<b>D</b>	IR reader connection (optional)	<b>J</b>	Gateway network port
<b>E</b>	Ribbon cable connection - connects to the bottom-left of the coil driver board	<b>K</b>	Ribbon cable connection - connects to the bottom-right of the coil driver board
<b>F</b>	Ribbon cable connection - connects to the top-left of the coil driver board		

## Right Coil Driver Board



The left coil driver board and the right coil driver board are the same. The connections to the gateway boards are different, so they are referenced as the “left” or “right” coil driver board.

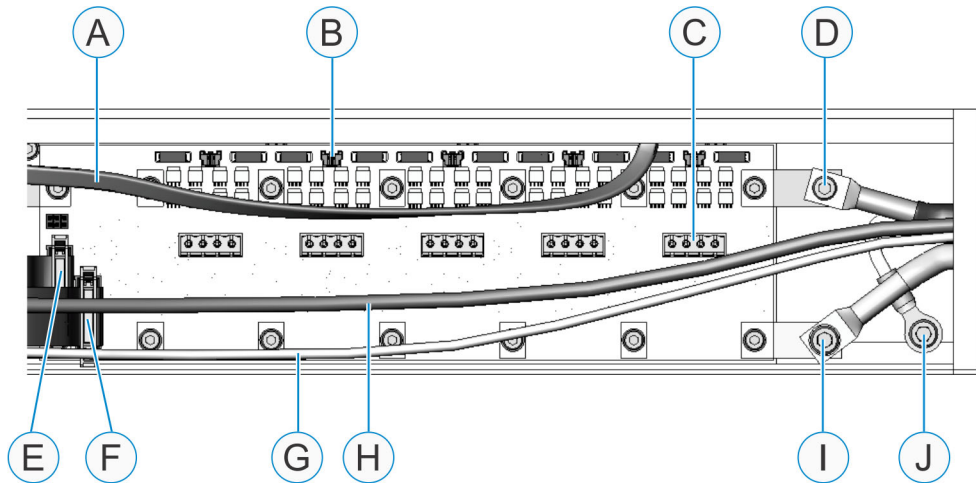

<b>A</b>	Right encoder cable	<b>F</b>	Ribbon cable connection - connects to the bottom-right of the coil driver board
<b>B</b>	Thermistor connector (1 of 5)	<b>G</b>	24V digital power cable (battery backup)
<b>C</b>	Coil connection (1 of 5: two coils for each connection)	<b>H</b>	Gateway network cable
<b>D</b>	Motor power connection <sup>a</sup>	<b>I</b>	Common connection
<b>E</b>	Ribbon cable connection - connects to the top-right of the coil driver board	<b>J</b>	Frame ground connection

a. The motor power connection is 28VDC between two (2) high power sections, and 15VDC between two (2) low power sections. There is no motor power connection between a high power section and a low power section.

## Curved Sections

A curved section provides a 180° or 90° turning path for the pallets to travel on between straight sections.

See [180 Deg. Section \(500 mm\) with Standard-Height Stands Data Sheet](#) on page 320, [180 Deg. Section \(500 mm\) with Low-Profile Stands Data Sheet](#) on page 323, and [180 Deg. Section \(800 mm\)](#) on page 326 for additional information.

### 180 Deg. Section (500 mm)

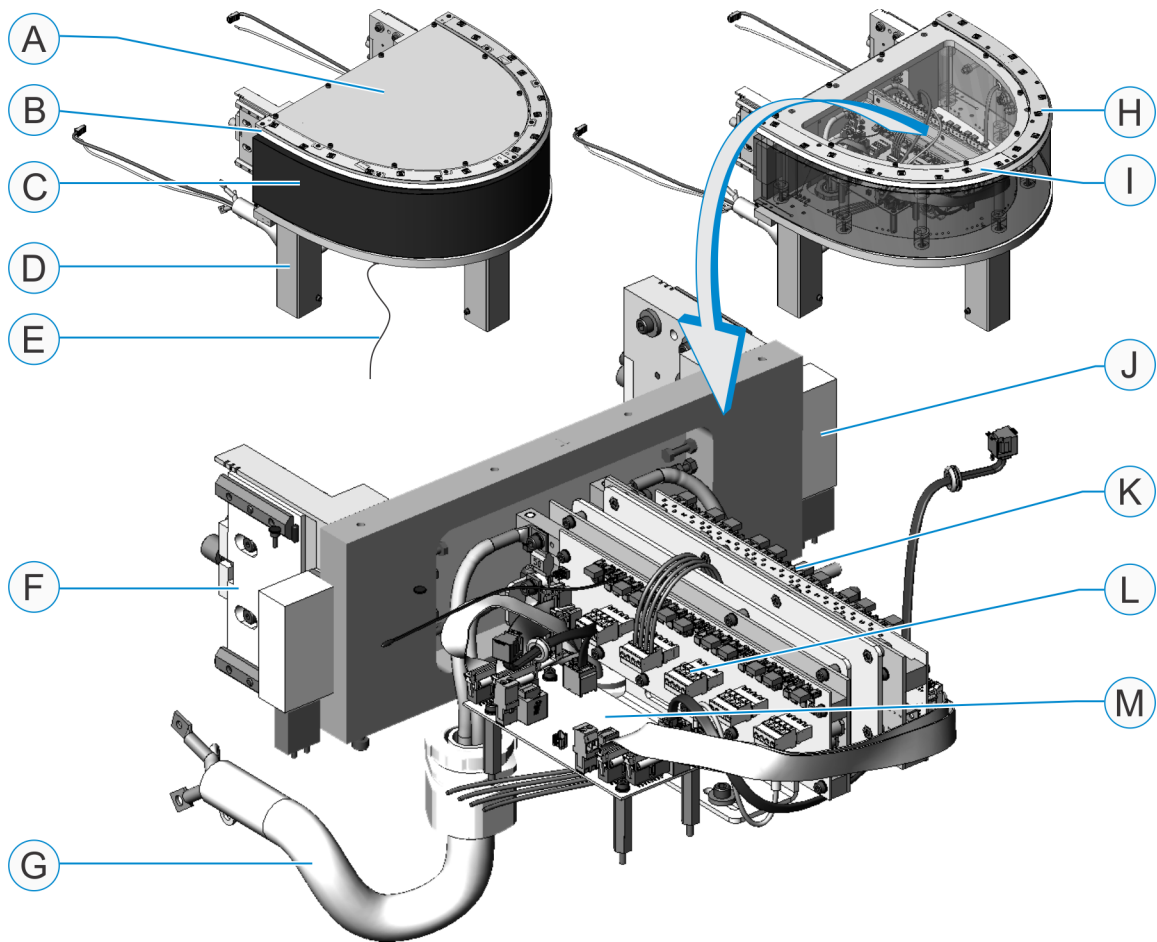

ID	Component Name	Description
A	Top cover	Provides access to the electronic boards.
B	Upper v-rail	Provides a track for the pallet v-wheels to travel on. The upper v-rail of the 180 deg. section is 1030 mm (40.5 in.) in length

ID	Component Name	Description
C	Motor	<p>Produces the electromagnetic force that propels the pallets. The motor includes:</p> <ul style="list-style-type: none"> <li>• Potted coils</li> <li>• Iron core lamination assembly</li> </ul> <p>See <a href="#">Coils</a> on page 39 for information about coil numbering.</p>
D	Stand (1 of 3)	<p>Mounts the section to the SuperTrak conveyance platform frame.</p> <p><i>180 deg. (500 mm) sections are available with standard-height stands as shown, or low-profile stands.</i></p>
E	Ground wire	<p>Provides the single point earth ground for the SuperTrak conveyance platform.</p> <p>Although each SuperTrak conveyance platform has two (2) 180 deg. sections, only one (1) 180 deg. section contains a single point earth ground wire. The single point earth ground wire is connected from the bottom plate of the 180 deg. section to the main electrical panel.</p>
F	Wedge adjust	Connects the 180 deg. section to a straight section.
G	Electrical interconnect	<p>Houses the power and network cables.</p> <p>See <a href="#">Interconnect (SuperTrak Control Panel to Curved Section)</a> on page 350.</p>
H	Right encoder assembly	Measures the pallet position using encoder read heads.
I	Left encoder assembly	See <a href="#">Encoder Assemblies</a> on page 38 for information about encoder numbering.
J	Magnetic shunt	Provides magnetic field continuity between adjacent sections.
K	Right coil driver board	See <a href="#">Right Coil Driver Board</a> on page 31.
L	Left coil driver board	See <a href="#">Straight Section - Left Coil Driver Board</a> on page 28, or <a href="#">Left Coil Driver Board with a Power Supply Connected</a> on page 29
M	Gateway board	See <a href="#">Gateway Board</a> on page 30.

180 Deg. Section (800 mm)

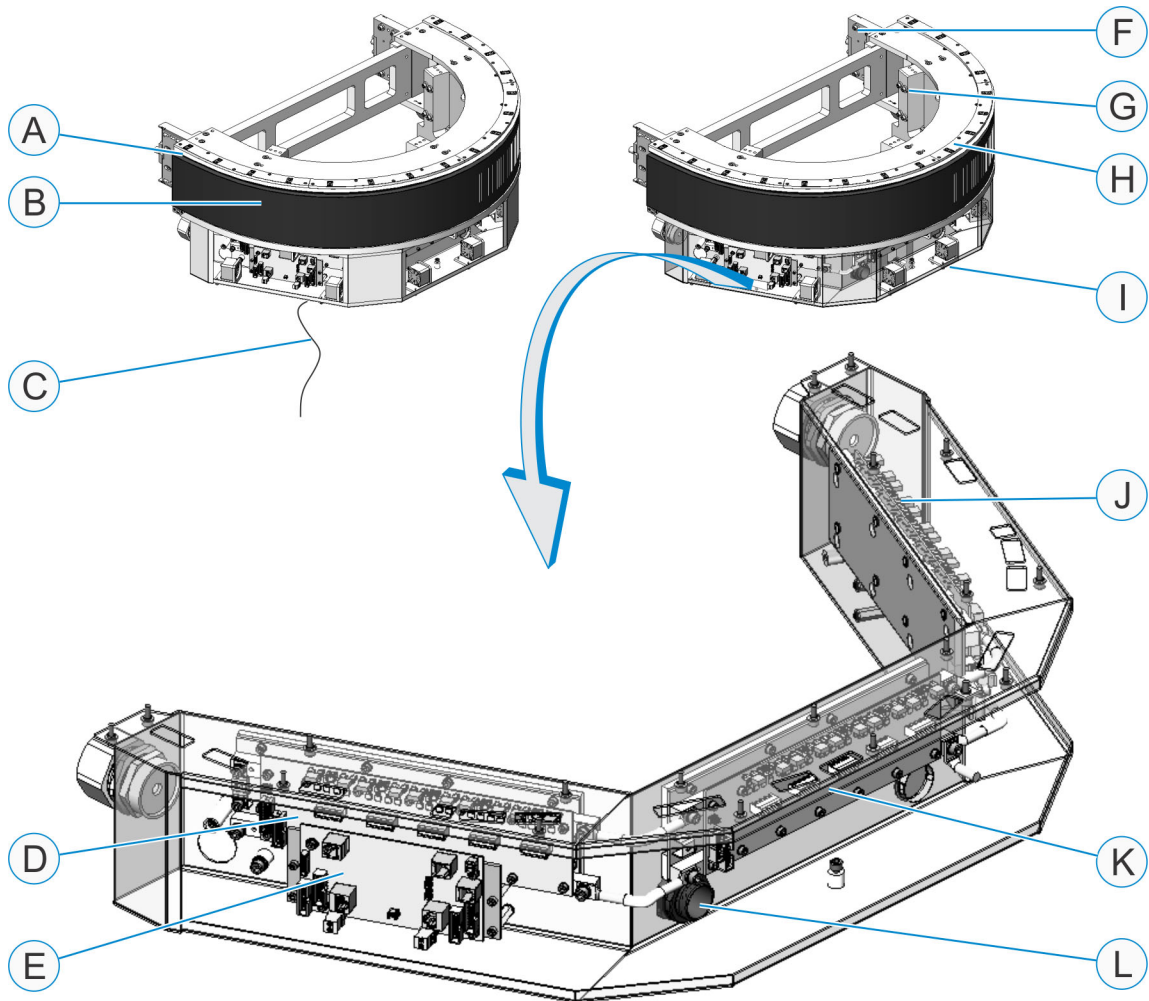

ID	Component Name	Description
A	Upper v-rail	Provides a track for the pallet v-wheels to travel on. The upper v-rail of the 180 deg. section is 1518.7 mm (59.79 in.) in length
B	Motor	Produces the electromagnetic force that propels the pallets. The motor includes: <ul style="list-style-type: none"> <li>• Potted coils</li> <li>• Iron core lamination assembly</li> </ul> See <a href="#">Coils</a> on page 39 for information about coil numbering.

ID	Component Name	Description
C	Ground wire	Provides the single point earth ground for the SuperTrak conveyance platform. Although each SuperTrak conveyance platform has two (2) 180 deg. sections, only one (1) 180 deg. section contains a single point earth ground wire. The single point earth ground wire is connected from the bottom plate of the 180 deg. section to the main electrical panel.
D	Left coil driver board (behind the gateway board) (1 of 3)	See <a href="#">Straight Section - Left Coil Driver Board</a> on page 28.
E	Gateway board (1 of 2)	See <a href="#">Gateway Board</a> on page 30.
F	Wedge adjust and a magnetic shunt	Aligns curved sections to adjacent sections and improves the continuity of the magnetic field.
G	Adjustable stand (1 of 3)	Allows height adjustment and leveling.
H	Encoder assembly	Measures the pallet position using encoder read heads. See <a href="#">Encoder Assemblies</a> on page 38 for information about encoder numbering.
I	Electrical door (1 of 3)	Encloses the electrical components.
J	Left coil driver board (3 of 3) & gateway board (2 of 2)	See <a href="#">Right Coil Driver Board</a> on page 31 and Gateway Board Diagram below.
K	Right coil driver board (2 of 3)	See <a href="#">Right Coil Driver Board</a> on page 31.
L	Control panel cable entry	Houses the power and network cables.

90 Deg. Section

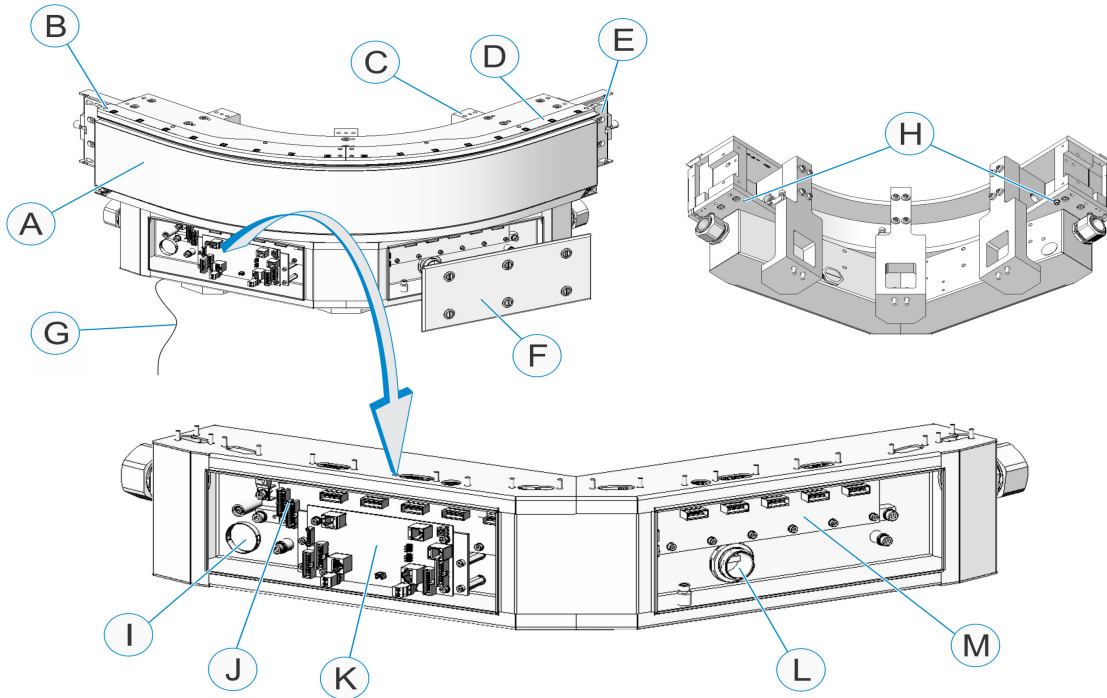

ID	Component Name	Description
A	Motor	Produces the electromagnetic force that propels the pallets. The motor includes: <ul style="list-style-type: none"> <li>• Potted coils</li> <li>• Iron core lamination assembly</li> </ul> See <a href="#">Coils</a> on page 39 for information about coil numbering.
B	Upper v-rail	Provides a track on which the the pallet v-wheels can travel . The upper v-rail of the 90 deg. section is 1003.3 mm (39.5in.) in length
C	Adjustable stand (1 of 3)	Allows height adjustment and leveling.
D	Encoder assembly	Measures the pallet position using encoder read heads. See <a href="#">Encoder Assemblies</a> on page 38 for information about encoder numbering.
E	Wedge adjust and a magnetic shunt	Aligns curved sections to adjacent sections and improves the continuity of the magnetic field.
F	Electrical door (1 of 2)	Encloses the electrical components.



ID	Component Name	Description
<b>G</b>	Ground wire	Provides the single point earth ground for the SuperTrak conveyance platform.  Although each SuperTrak conveyance platform has four (4) 90 deg. sections, only one (1) 90 deg. section contains a single point earth ground wire. The single point earth ground wire is connected from the bottom plate of the 90 deg. section to the main electrical panel.
<b>H</b>	Ground cable connection point	Points the connection of the ground wire (G).
<b>I</b>	Power supply entry	Provides a space where the power supply can be connected to the section.
<b>J</b>	Left coil driver board	See <a href="#">Straight Section - Left Coil Driver Board</a> on page 28.
<b>K</b>	Gateway board	See <a href="#">Gateway Board</a> on page 30.
<b>L</b>	Control panel cable entry	Houses the power and network cables.
<b>M</b>	Right coil driver board,	See <a href="#">Right Coil Driver Board</a> on page 31.

### Encoder Assemblies

Each straight section, 180 deg. section (500 mm), and 90 deg. section has two (2) encoder assemblies: a left encoder assembly and a right encoder assembly. Every encoder assembly has eight (8) encoder read heads, which look like black squares on the top of the encoder assembly. The encoders are used for pallet position feedback.

Encoder numbering begins at the left side of a left encoder assembly and ends at the right side of the right encoder assembly. The following diagram illustrates how the encoders are numbered 0 to 15 from left to right, for each SuperTrak conveyance platform section:

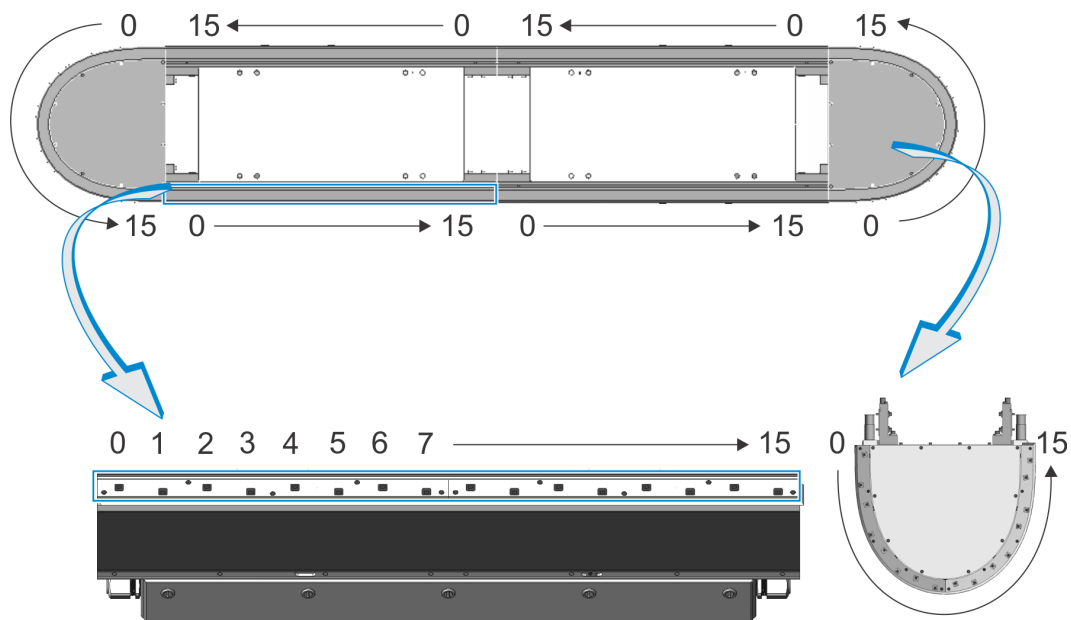

Each 180 deg. section (800 mm) has four (4) encoder assemblies: a left encoder assembly, two (2) center encoder assemblies, and a right encoder assembly. The functionality is the same as described above except that the encoders are numbered 0 to 7 from left to right, as pictured at right.

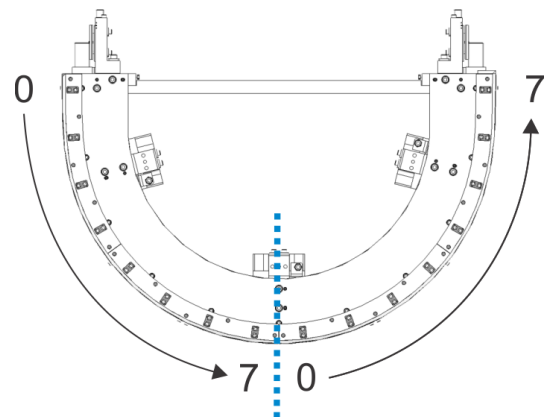

**Coils**

Each straight section, 180 deg. section (500 mm), and 90 deg. section has twenty (20) coils. A coil pair is connected to each of the five (5) coil connections on the left coil driver board, and a coil pair is connected to each of the five (5) coil connections on the right coil driver board. The coils are numbered 0 to 19 from left to right.

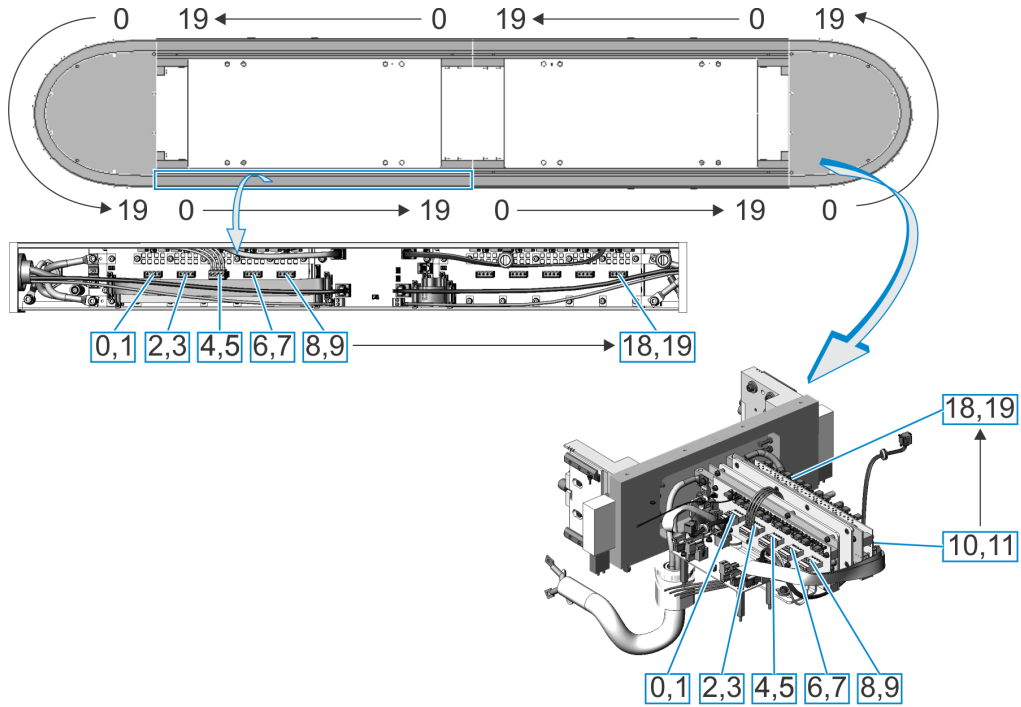

Each 180 deg. section (800 mm) has thirty (30) coils. The functionality is the same as described above except that the 180 deg. section (800 mm) has three (3) coil driver boards. As shown, the coils are numbered 0 to 19, and then 0 to 9 from left to right.

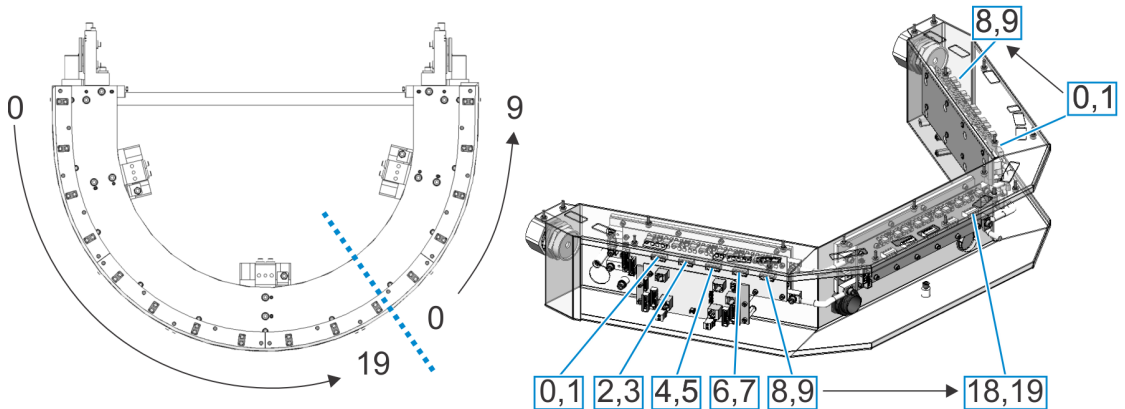

## Control Panel



**WARNING**

Servicing an electrical panel that is still connected to its power source may cause injury or death. Unless directed otherwise, turn the **main power disconnect switch** to the OFF position. Lockout and tagout the switch before accessing and servicing the electrical panel. Only qualified electrical technicians should perform service on the electrical panel.

See [Hazardous Energy](#) on page 8 and [Lockout and Tagout](#) on page 11.



If an ATS control panel is not used, a line filter is required (for example, a Schaffner "FN 3256H-XX").

The control panel provides power to the SuperTrak conveyance platform only. It is designed to be integrated with a main electrical panel, and requires a protective earth connection from the main electrical enclosure.

See [Control Panel Data Sheet](#) on page 332 for additional information.

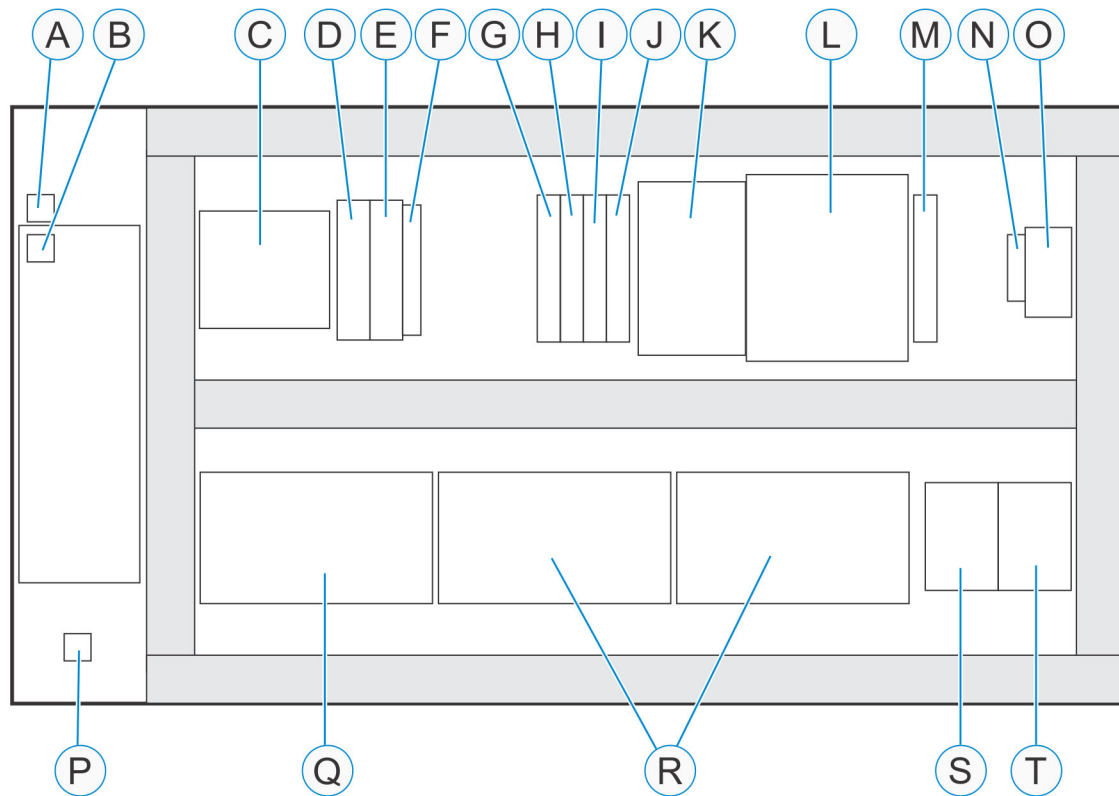

<b>A</b>	Ground	<b>K</b>	24V digital power supply
<b>B</b>	Controller - TrakMaster EtherNet connection	<b>L</b>	Uninterrupted power supply (UPS)
<b>C</b>	Terminals	<b>M</b>	10A breaker - 24V digital power supply

<b>D</b>	PLC connection (EtherNet/IP, EtherCAT, or PROFINET)	<b>N</b>	UPS disconnect <sup>a</sup>
<b>E</b>	Bus controller (POWERLINK)	<b>O</b>	SuperTrak conveyance platform power disconnect switch (3 phase) <sup>b</sup>
<b>F</b>	Power supply module	<b>P</b>	Single point ground connection
<b>G</b>	Breaker - enclosure fan	<b>Q</b>	Terminals
<b>H</b>	13A breaker - All SuperTrak conveyance platform digital power	<b>R</b>	Power supply breakers (space for 6 or 12 breakers)
<b>I</b>	6A breaker - controller	<b>S</b>	Safety contactor #1
<b>J</b>	2A breaker - I/O bus coupler	<b>T</b>	Safety contactor #2

a.Disconnects the 24V digital battery power

b.Disconnects the AC power to the SuperTrak conveyance platform.

## Power Supply



**WARNING**

Servicing an electrical panel that is still connected to its power source may cause injury or death. Unless directed otherwise, turn the **main power disconnect switch** to the OFF position. Lockout and tagout the switch before accessing and servicing the electrical panel. Only qualified electrical technicians should perform service on the electrical panel.

See [Hazardous Energy](#) on page 8 and [Lockout and Tagout](#) on page 11.

The power supply is an AC to DC power supply that provides 28VDC to the SuperTrak conveyance platform for pallet motion. Each power supply is wired to a control panel. Alternating-current (AC) electrical power is supplied to the power supply from the control panel by a cable plug.

The required number of power supplies varies depending on the demands of the specific SuperTrak conveyance platform.

Every power supply has a label affixed to it that indicates the date it was tested and the initials of the tester. This label verifies that the power supply was inspected and tested. If this label does not exist or an unauthorized replacement power supply is used, contact ATS for the correct power supply replacement.

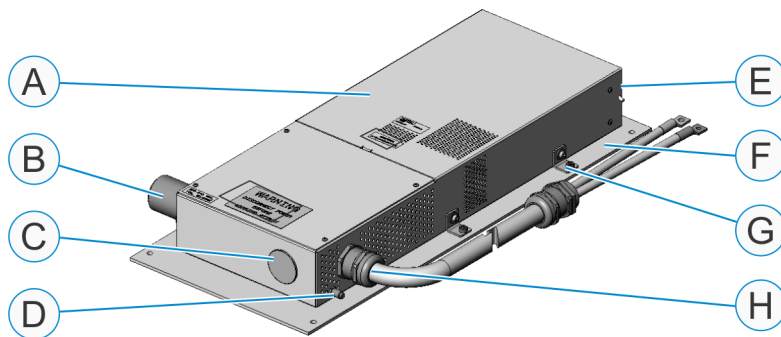

<b>A</b>	Power supply cabinet	<b>E</b>	Power supply filter
<b>B</b>	AC power input plug	<b>F</b>	Power supply mounting plate
<b>C</b>	Alternate 28 VDC power output location	<b>G</b>	Power supply mounting brackets
<b>D</b>	Power supply OK signal	<b>H</b>	28 VDC power output location

See [Power Supply Data Sheet](#) on page 335, and [Replace the Main Motor Fuse](#) on page 173 for additional information.

## IR Reader Assembly (Optional)



The IR reader assembly contains an infrared emitting diode (IR LED) that is classified as eye safe. The following standards and classifications apply:

- IEC/EN 60825-1 (2007-03), DIN EN 60825-1 (2008-05) "SAFETY OF LASER PRODUCTS - Part 1: equipment classification and requirements", simplified method. This is classified as "Class 1".
- IEC 62471 (2006), CIE S009 (2002) "Photo-biological Safety of Lamps and Lamp Systems". This is classified as "Exempt".
- DIRECTIVE 2006/25/EC OF THE EUROPEAN PARLIAMENT AND OF THE COUNCIL of 5th April 2006 on the minimum health and safety requirements regarding the exposure of workers to risks arising from physical agents (artificial optical radiation) (19th individual directive within the meaning of article 16(1) of directive 89/391/EEC). This is classified as "Exempt".
- ETSI EN 300 330 v2.1.1

The infrared (IR) pallet ID system is an optional SuperTrak conveyance platform system that allows for a customized pallet ID to be assigned to each pallet. The IR reader assembly includes an IR tag and IR reader (with cable). It provides the following benefits:

- Simplifies SuperTrak conveyance platform recovery after a complete cold start.
- Provides data integrity when pallets are manually removed.
- Provides tracking of individual pallet fixtures.
- Pallet IDs are read "on-the-fly": pallets do not stop at the IR reader assembly.
- It induces the necessary power into the tags for reading purposes. Batteries are not required.

Integration of the IRID reader assembly with the SuperTrak conveyance platform is Plug-and-play. External PLC programming is not required.

See [IR Reader Components \(Optional\) Data Sheet](#) on page 339, and [IR Reader Mount Assembly \(Optional\)](#) on page 44 for additional information.

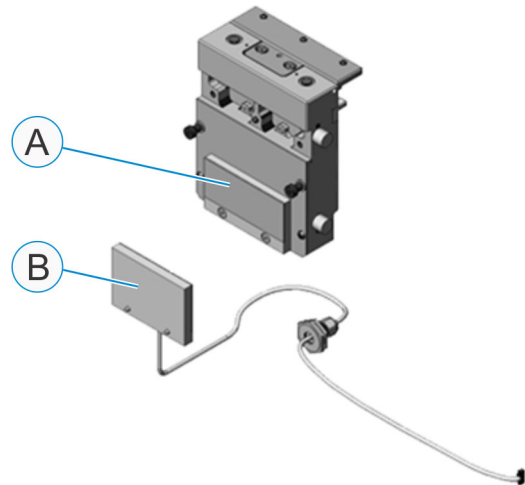

<b>A</b>	IR tag (read-only)
<b>B</b>	IR reader

## IR Reader Mount Assembly (Optional)

The infrared (IR) reader mount assembly is an optional assembly for mounting the IR reader assembly.

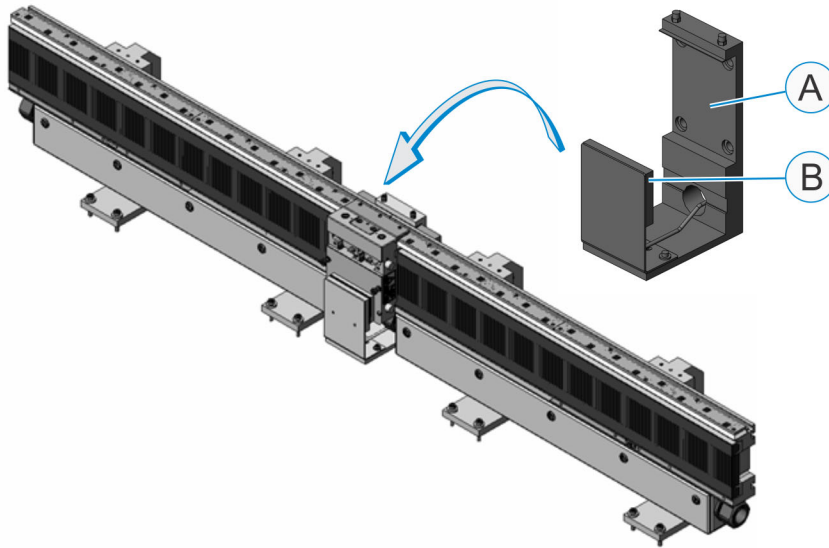

<b>A</b>	IR reader mount assembly	<b>B</b>	IR reader installation location
----------	--------------------------	----------	---------------------------------

See [IR Reader Components \(Optional\) Data Sheet](#) on page 339, and [Install an IR Reader Mount Assembly](#) on page 110 for additional information.



## Pallet Setup Tools (Optional)

The pallet setup tools are optional SuperTrak conveyance platform tools that allow you to align and calibrate SuperTrak pallet encoder strip assemblies.

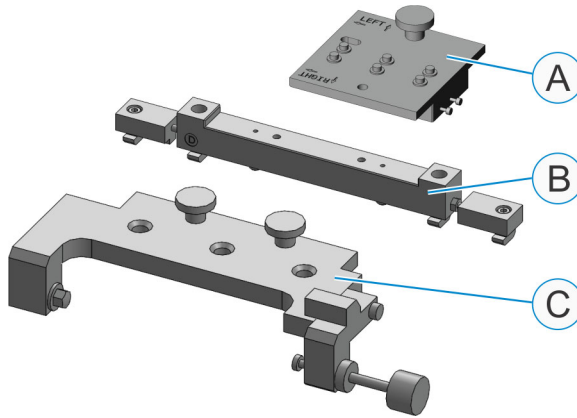

<b>A</b>	Pallet setup adjustable chip finder	<b>C</b>	Pallet setup removable locate
<b>B</b>	Pallet setup stationary mount		

See [Pallet Setup Tools \(Optional\) Data Sheet](#) on page 341 for additional information.

## Station Setup Tools (Optional)

The station setup tools are optional SuperTrak conveyance platform tools that allow you to physically hold a pallet in a precise location in order to align system-specific station tooling to that pallet.

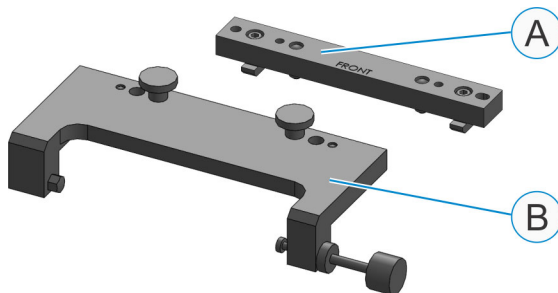

<b>A</b>	Station setup stationary mount	<b>B</b>	Station setup removal locate
----------	--------------------------------	----------	------------------------------

This page is intentionally blank.

# Installation

This section describes how to install the SuperTrak conveyance platform.

## Prerequisites

The following services and components are required to successfully install the SuperTrak conveyance platform:

- A non-compressing installation surface (for example; a concrete floor)
- Electrical connections to the SuperTrak conveyance platform control panel:
  - AC incoming power from the main electrical cabinet
    - North America: 208Y120+PE, 40A (or 20-30A on smaller systems)
    - Europe: 400Y230+PE, 40A (or 20-30A on smaller systems)
  - Safety circuit connection (fail safe digital 24V output to enable motor power)
  - PLC network connections (EtherNet/IP, PROFINET, or alternate)
- TrakMaster software
- Computer with Windows and network connectivity
- Ethernet cable
- Tools:
  - 0.5 mm (0.02 in.) shims
  - Feeler gages
  - Framing square
  - Mallet
  - Straight flat bar 38.5 cm (15.16 in.) long
  - Precision spirit level
  - Set of metric hex keys
  - Set of metric wrenches or spanners

## Install the SuperTrak Conveyance Platform



- Make sure the installation is done on a non-compressing surface (for example; concrete), so the sections can be leveled and aligned correctly.
- The maximum number of sections in a SuperTrak system is based on the gateway communication network's maximum capacity of sixty-four gateways. Each straight, 90 deg., and 1980 deg. (500 mm) section contains one gateway while each 180 deg. (800 mm) section contains two gateways. Therefore, a system using straight sections with only 180 deg. (500 mm) or 90 deg. sections could have sixty-four sections total, while a system using 180 deg. (800 mm) sections would be limited to sixty-two total sections.

Complete the procedures in this section in the order that they are written.

1. Calculate the space required to install the SuperTrak conveyance platform, to verify that there is adequate space.
2. Complete one (1) of the following, depending on the type of frame that is used:
  - Install the SuperTrak conveyance platform on a SuperTrak GEN3 frame.  
See [Install the SuperTrak Conveyance Platform on a SuperTrak GEN3 Frame](#) on page 49.
  - Install the SuperTrak conveyance platform on a custom frame.  
See [Install the SuperTrak Conveyance Platform Sections with Custom Stands on a Custom Frame](#) on page 50.
  - Install the SuperTrak conveyance platform in an over/under configuration.  
See [Install the SuperTrak Conveyance Platform in an Over/Under Configuration](#) on page 64.
3. Install the required cable connections.  
See [Connections](#) on page 116.
4. Verify that the upper v-rail is adequately lubricated.  
If required, add an additional 20 drops of lubricant to the pallet lubrication felt, or manually wipe lubricant on the upper v-rail. Remove excess oil from the SuperTrak that may have dripped from the upper v-rail.

## Install the SuperTrak Conveyance Platform on a SuperTrak GEN3 Frame

1. Install the first SuperTrak conveyance platform section.  
See [Install the First SuperTrak Conveyance Platform Section](#) on page 92.
2. Install the next SuperTrak conveyance platform section.  
See [Connect Two SuperTrak Conveyance Platform Sections Together](#) on page 96.
3. Repeat the preceding step until all SuperTrak conveyance platform sections are connected together.
4. Verify that a 0.5 mm (0.02 in.) gap still exists between all sections.

In the example below, the gap is checked in twenty (20) locations: at the top and bottom of each section joint that is indicated by an arrow.

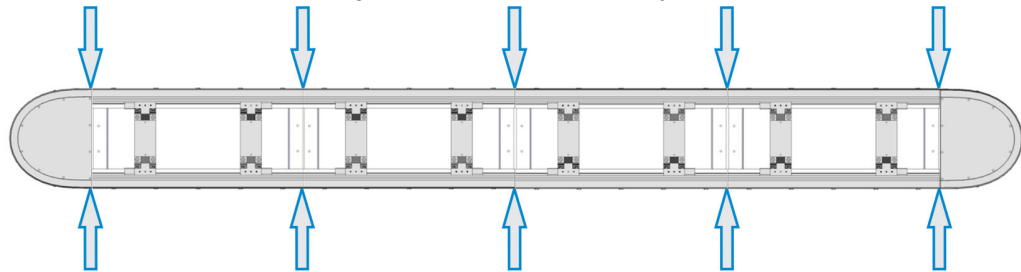

See step 7 from [Connect Two SuperTrak Conveyance Platform Sections Together](#) on page 96, if additional information is required.

5. Align the SuperTrak conveyance platform section joints.  
See [Align the SuperTrak Conveyance Platform Section Joints](#) on page 98.
6. Align the SuperTrak conveyance platform section heights.  
See [Align the SuperTrak Conveyance Platform Section Heights](#) on page 99.
7. Install the wedge adjust.  
See [Install a Wedge Adjust](#) on page 100.
8. Align the upper v-rail.  
See [Replace an Upper V-Rail](#) on page 230.
9. Install the lower flat wear strips.  
See [Replace a Flat Wear Strip](#) on page 238.
10. Install the pallets.  
See [Install a Pallet](#) on page 191.
11. If required, fine-adjust the upper v-rail.  
See [Fine-Adjust the Upper V-Rail](#) on page 103.

## Install the SuperTrak Conveyance Platform Sections with Custom Stands on a Custom Frame

** DANGER**

Always use appropriate lifting devices (for example, a forklift or crane) and use safe lifting practices and procedures when lifting a straight or curved section.

See [Lift a SuperTrak Conveyance Platform Section](#) on page 74.

ATS recommends that you obtain relevant information from your national Health and Safety Authority.

**NOTICE**

Make sure the custom frame is designed to hold the weight and force of the SuperTrak conveyance platform sections.



- This procedure assumes that the Y-axis movement of the custom stands is  $\leq 0.002$  in. ( $\leq 0.05$  mm) when the stands are parallel, the stands allow for Y-axis and Z-axis adjustment, and the stands include the correct hole pattern.
- This procedure assumes that the custom frame includes the correct hole pattern on the top and sides of the frame.

See the SuperTrak conveyance platform *Mechanical Drawings* and the *SuperTrak GEN3 Design Considerations* documents for additional information.

This section describes how to install SuperTrak conveyance platform sections on custom stands and a custom frame in cases where the SuperTrak system is not provided assembled and configured with stands. ATS stands and an ATS frame are shown for reference.

1. Inspect the frame to verify that it includes the correct features outlined in the SuperTrak conveyance platform *Mechanical Drawings*.
2. Position the frame on a flat non-compressing surface.
3. If custom stands are used with straight sections, install those stands; otherwise, proceed to step 4:
  - a. Inspect the stands to verify that they include the correct features outlined in the *SuperTrak GEN3 Design Considerations* document.

This procedure assumes that the Y-axis movement of the custom stands is  $\leq 0.002$  in. ( $\leq 0.05$  mm) when the stands are parallel, the stands allow for Y-axis and Z-axis adjustment, and the stands include the correct hole pattern.
  - b. Lift the section.

See [Lift a SuperTrak Conveyance Platform Section](#) on page 74.
  - c. As required, attach the stands to the straight sections.

4. Position all straight sections on the frame, with the electrical box facing out.

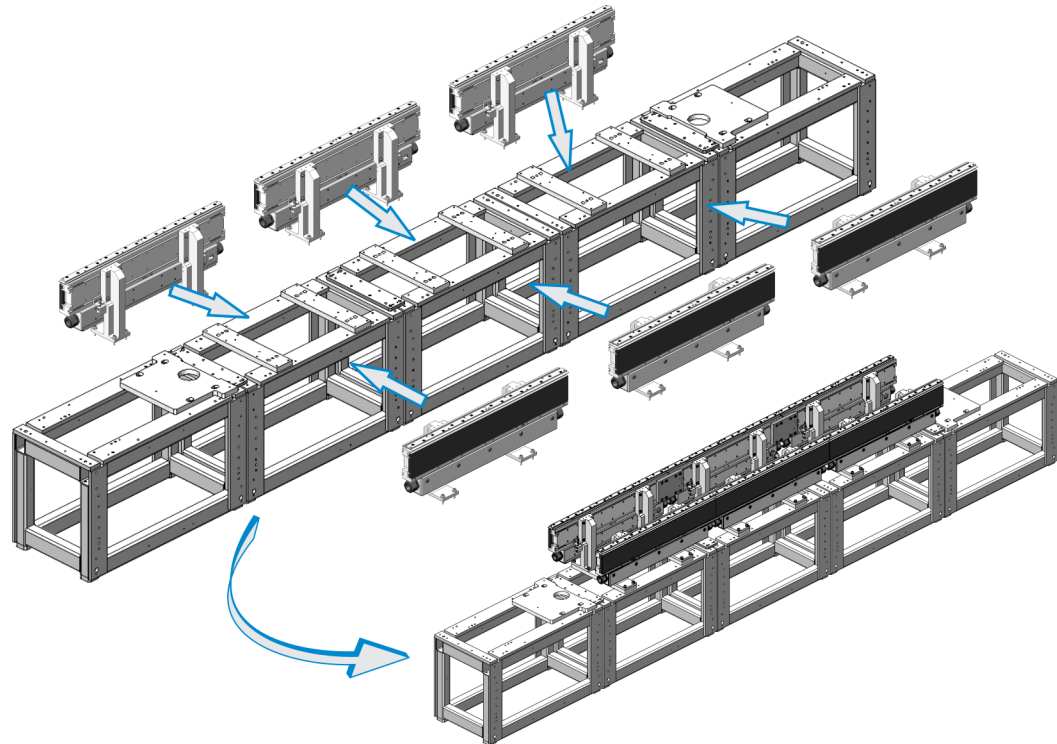

5. Push each straight section toward the center of the frame, so it is tight against the dowel pins in the frame.

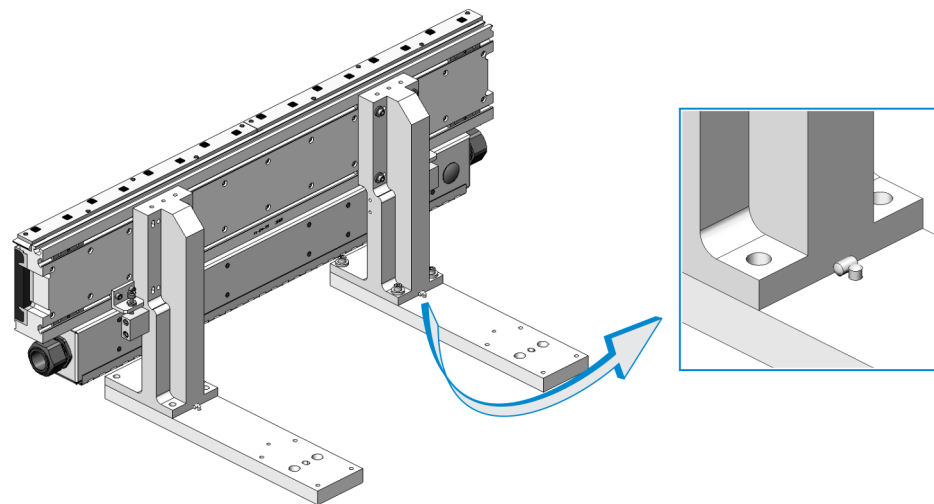
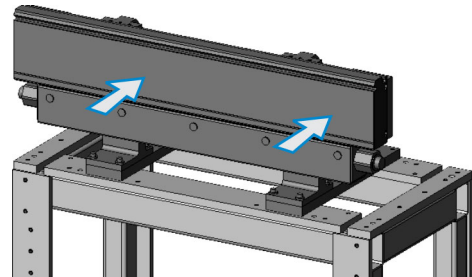

6. Loosely install four (4) screws into each stand base.

It is very important that the screws are centered in the screw holes as much as possible. This allows for adjustment when sections are connected together later.

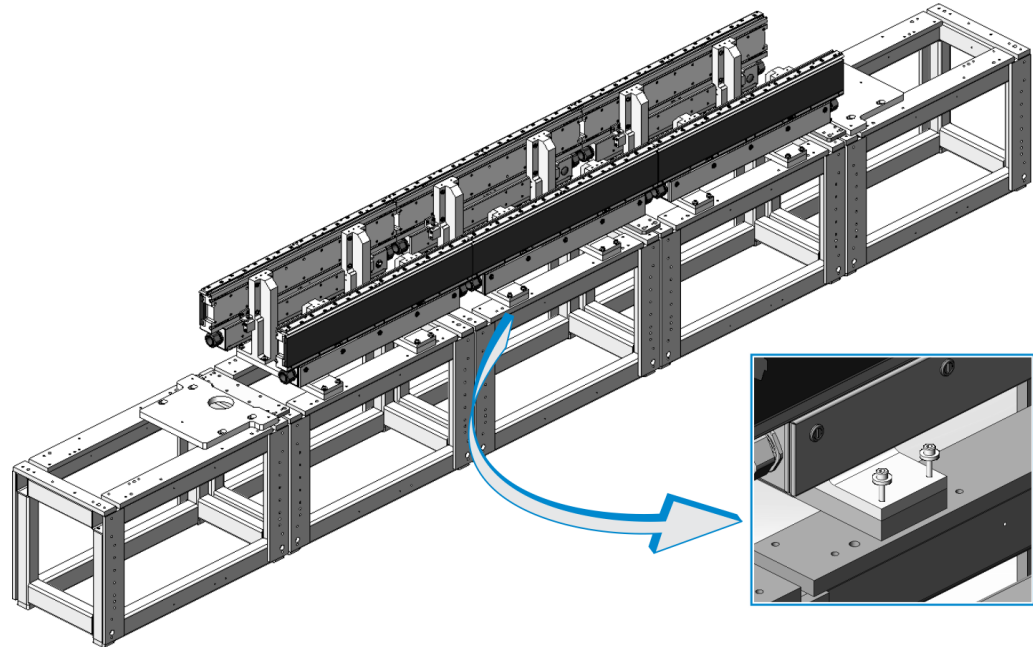



7. Adjust the position of the straight sections until:

- Use shims to verify that a 0.5 mm (0.02 in.) gap exists between all straight sections (between the track structure [or aluminum extrusion], not between the linear motors [or motor laminations]).

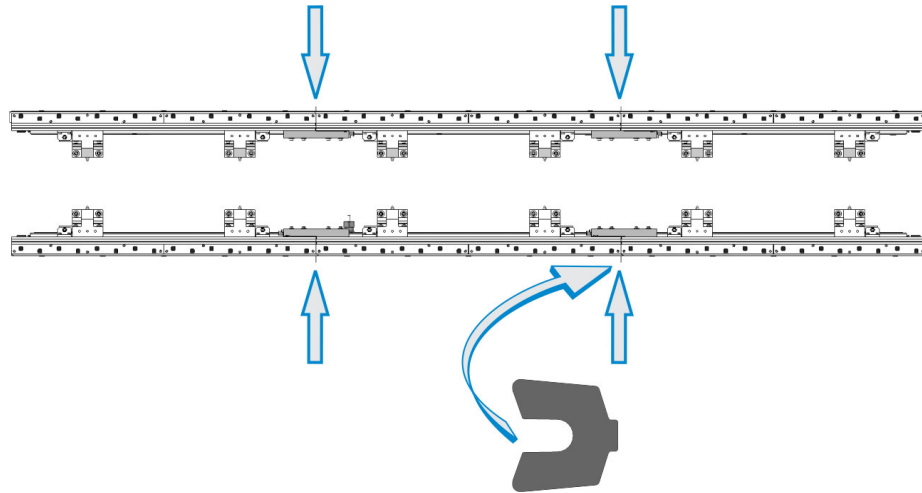

- The two (2) straight sections are reasonably square at each end.

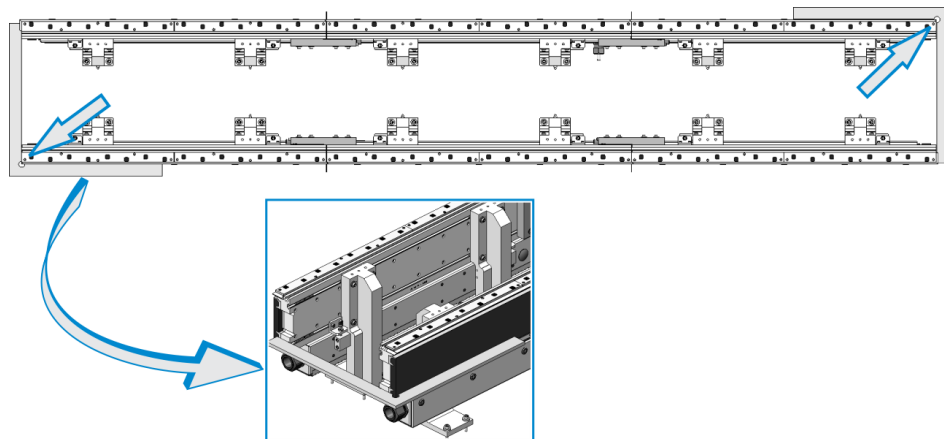

8. Verify that the following are aligned:
- Upper v-rails and flat wear strip pockets.

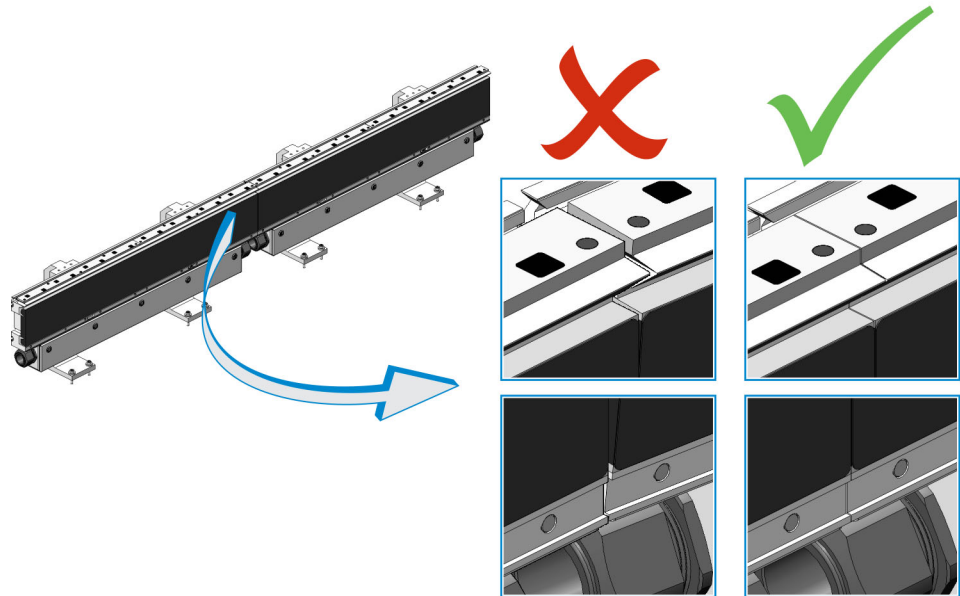

- Back of the laminations at all joints.

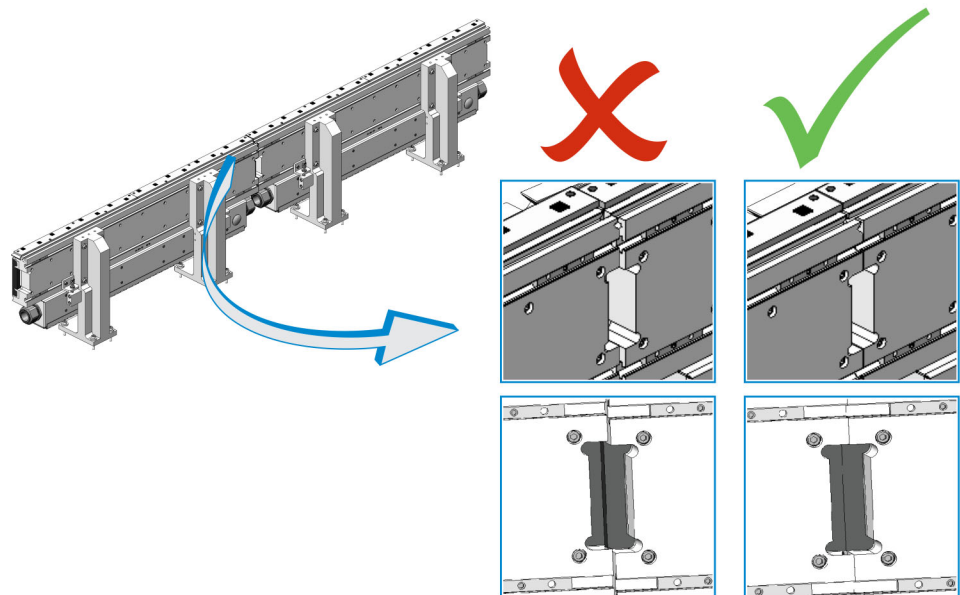

Fix any major misalignment before proceeding with fine alignment.

9. Level the first straight section.

Place the precision level on the t-slot behind the encoder assembly of the straight section when leveling.

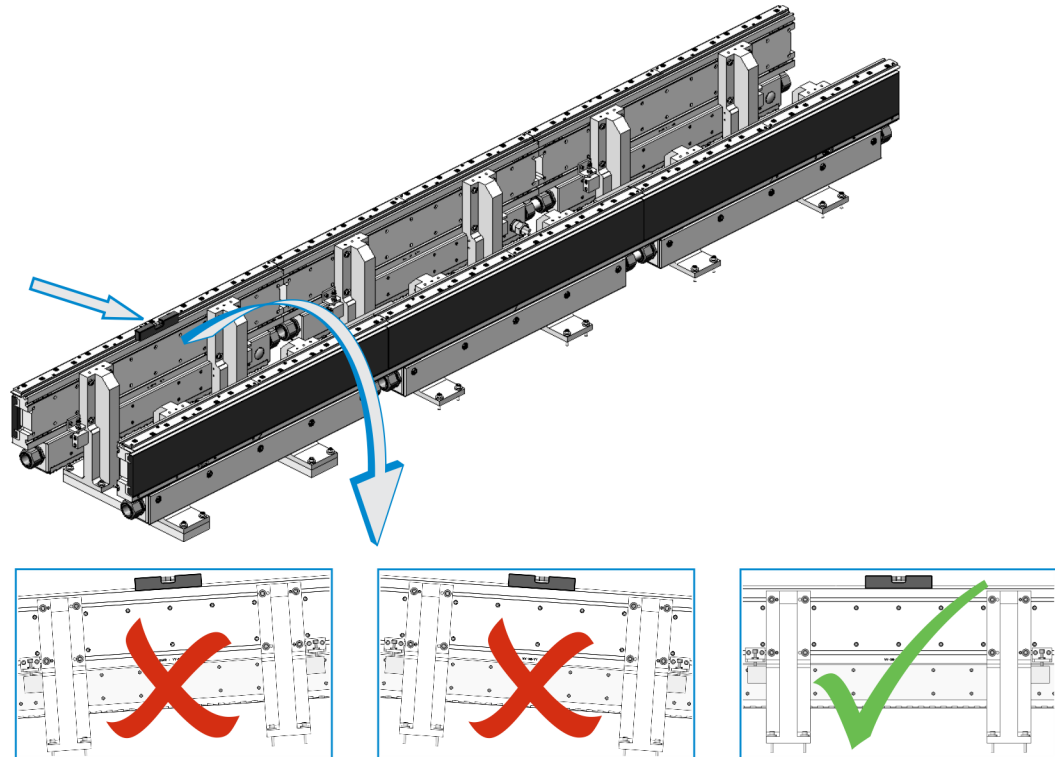

10. Level the second straight section, and then adjust it vertically to align the upper v-rails with the first straight section while keeping the section level.

See [Align the SuperTrak Conveyance Platform Section Joints](#) on page 98, and [Align the SuperTrak Conveyance Platform Section Heights](#) on page 99 for additional information.

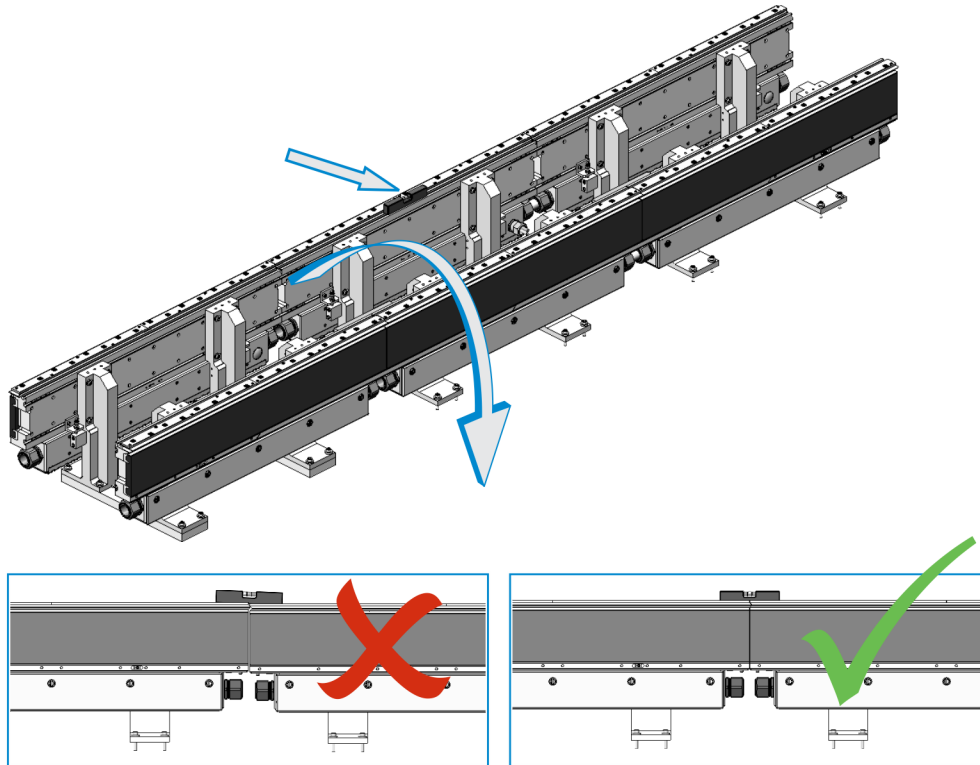

11. Install a wedge adjust between the straight sections.

See [Install a Wedge Adjust - Straight Section](#) on page 100.

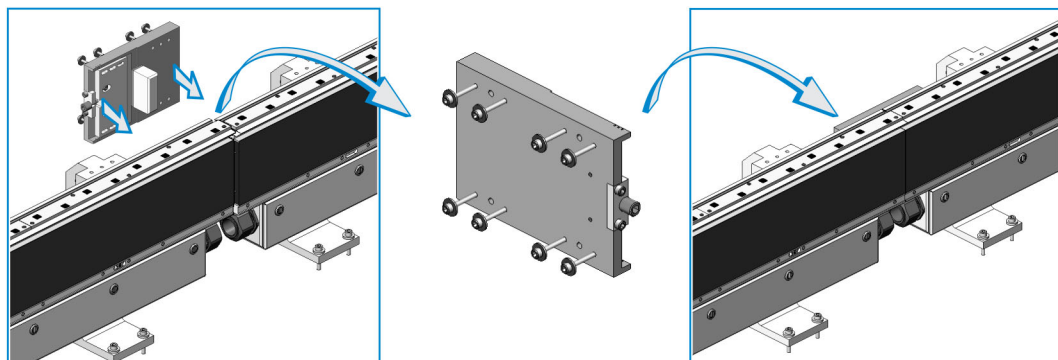

- Adjust the wedge IN or OUT to align the upper v-rails. Only adjust when the wedge adjust screws are loose, and measure when the wedge adjust screws are tight.

See *Fine-Adjust the Upper V-Rail* on page 103.

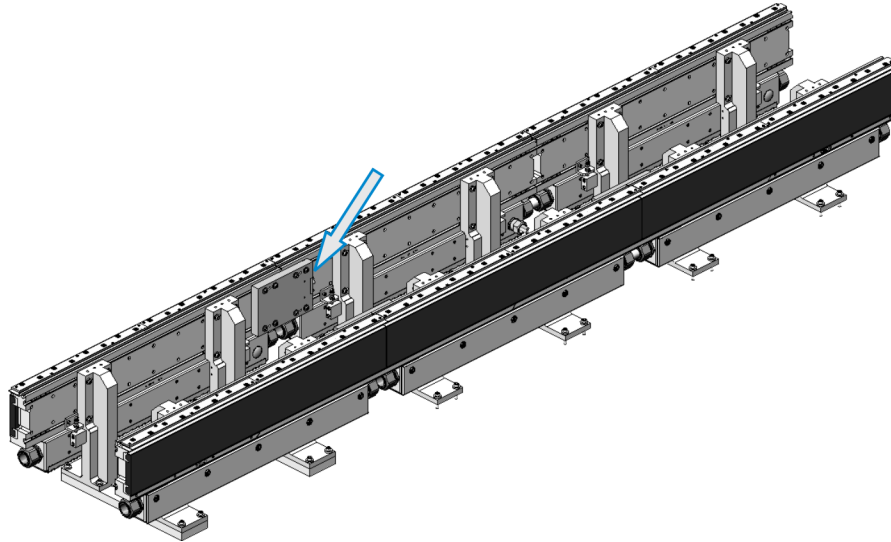

- Repeat steps 10 to 12 for the remaining sections on the same side of the SuperTrak conveyance platform.

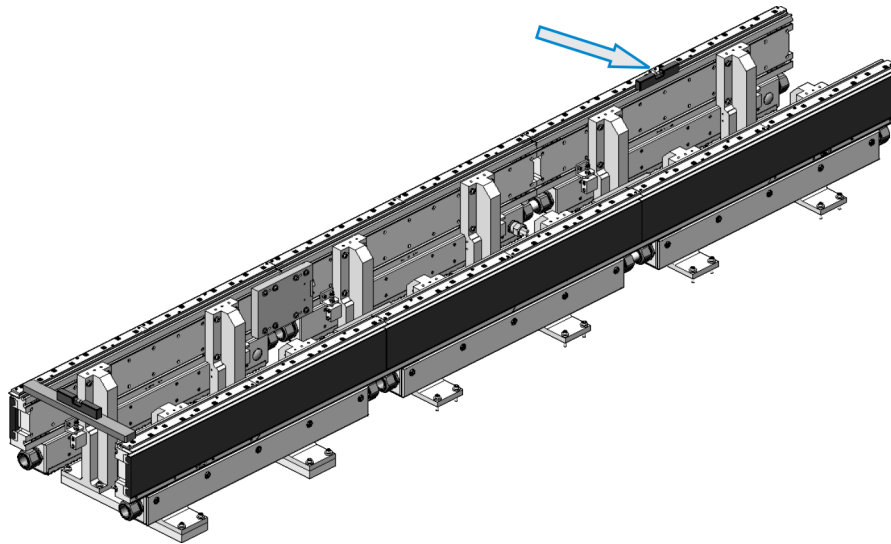

14. Return to the first straight section and lay a flat bar across it and the opposing straight section.

Make sure the flat bar rests on the t-slot and not the encoder assemblies. Level the opposing section with the first section.

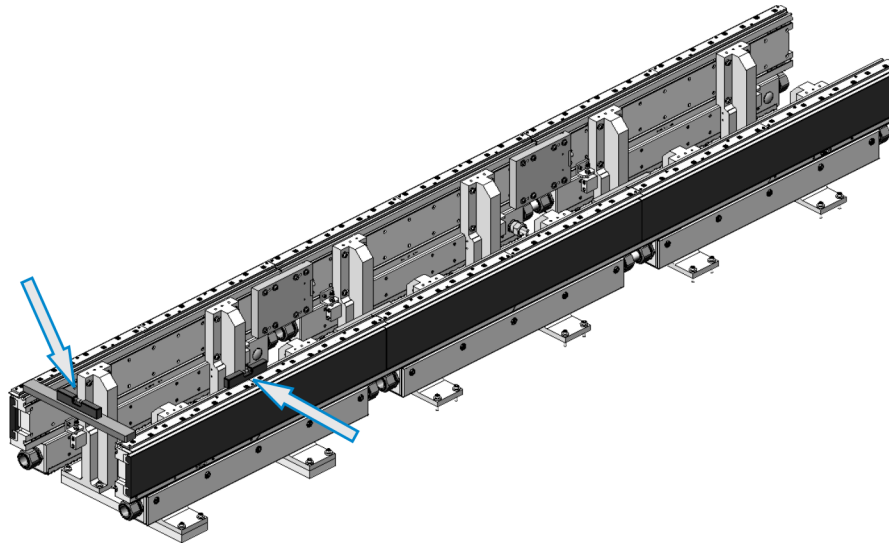

15. Repeat steps 10 to 12 for the remaining sections on the same side of the SuperTrak conveyance platform.

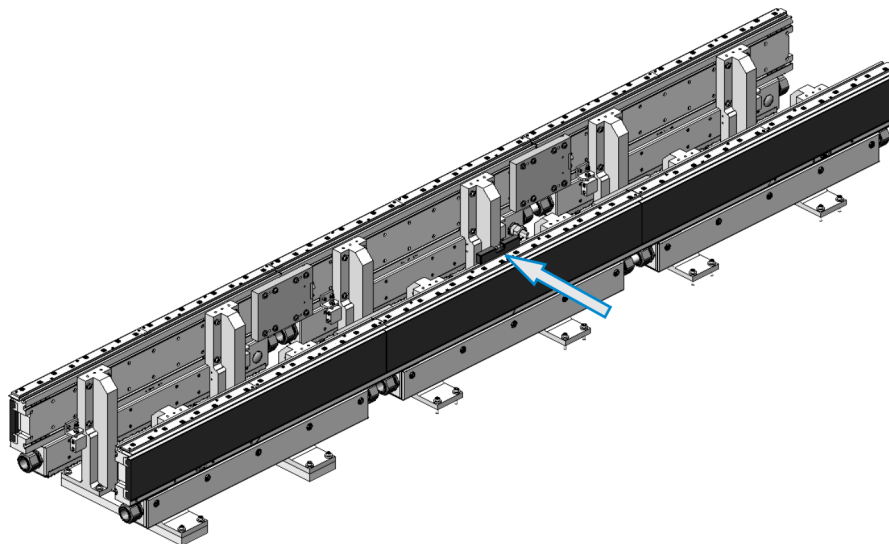

16. Install the first curved section.
17. For 180 deg. sections, use shims to verify that a 0.5 mm (0.02 in.) gap exists between the 180 deg. section and each of the two (2) abutting straight sections (between the track structure [or aluminum extrusion], not between the linear motors [or motor laminations]).

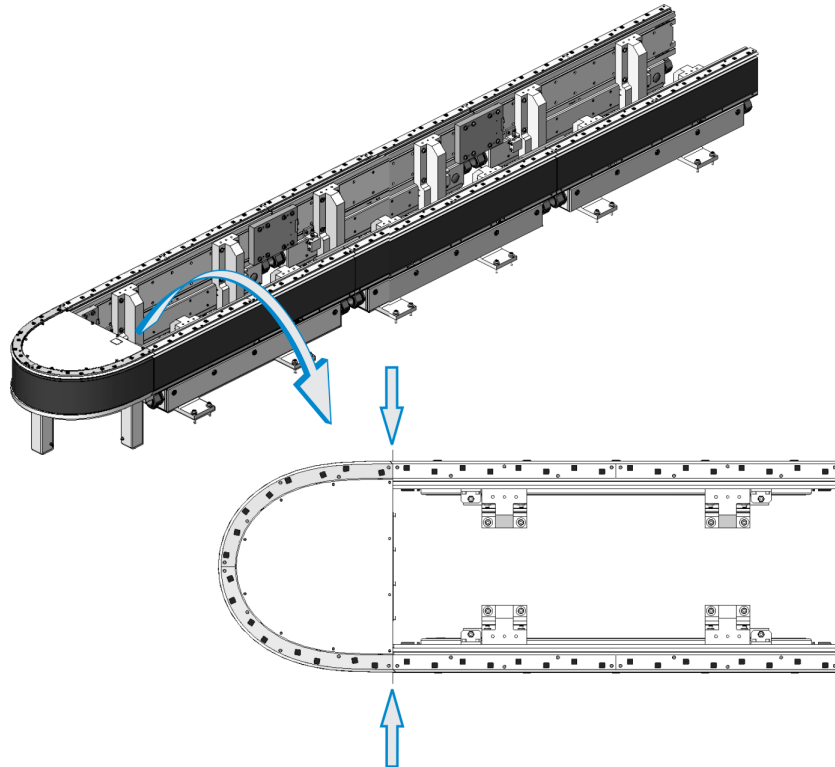

For 90 degree sections, use shims to verify that a 0.5 mm (0.02 in.) gap exists between the 90 deg. section and each of the two (2) abutting sections.

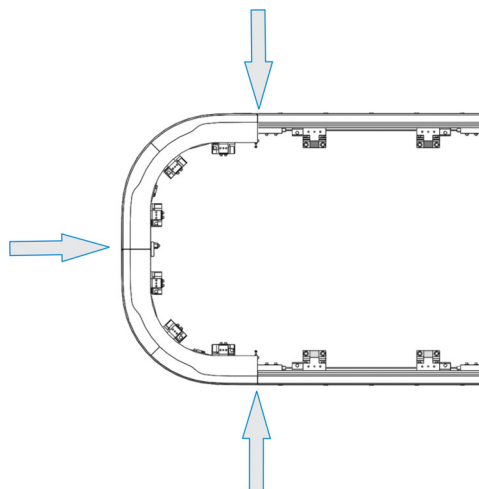

18. Adjust the vertical, horizontal, and side-to-side positions until the upper v-rails align with the straight sections, and the curved section is centered between the straight sections.

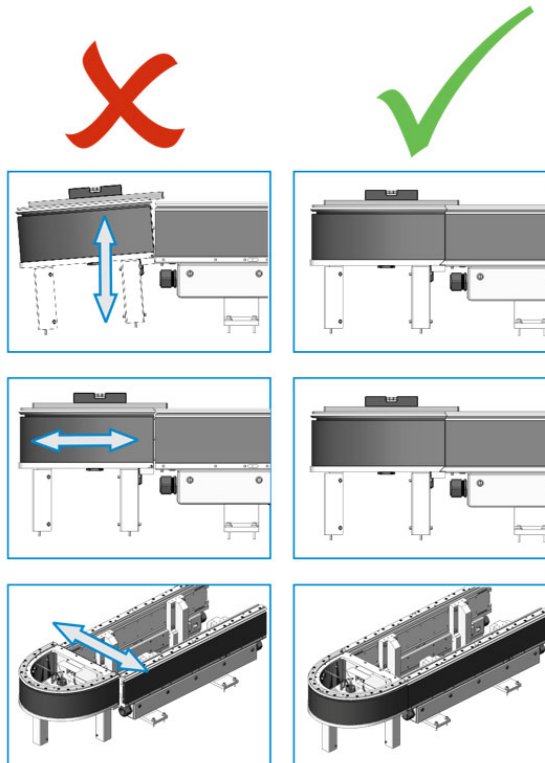



**For 180 deg. (500 mm) sections:** Remove the top cover form the 180 deg. section, remove the covers from the 180 deg. section stands, and then level the 180 deg. section.

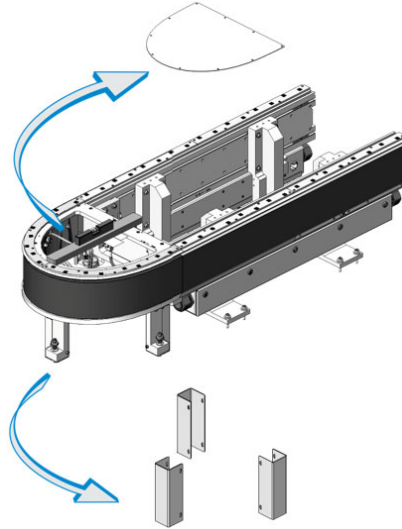

**For 180 deg. (800 mm) and 90 deg. curved sections:**

Level the curved section:

- a. Place a precision spirit level across the frame in the directions illustrated, to determine the leveling foot (or feet) that requires adjustment.

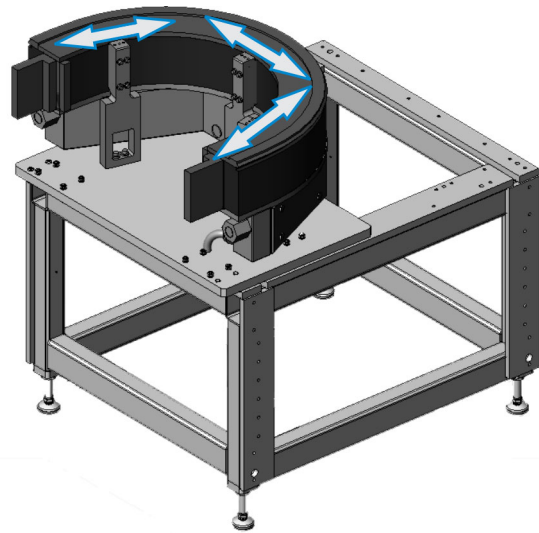

- b. Loosen the four (4) screws on each stand.

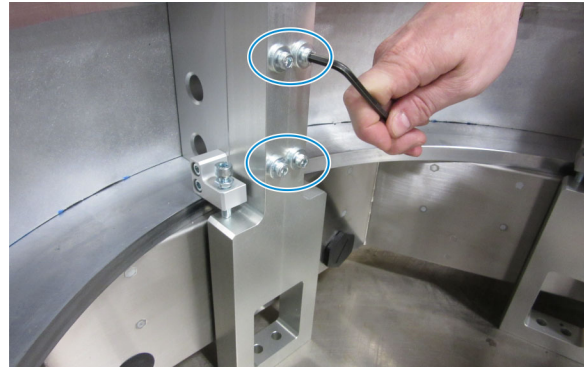

- c. Loosen the upper lock nut.  
d. Turn the leveling screw as required, to raise or lower the side of the wide 180 deg. section.



- e. Use a level to verify that the curved section is level.  
f. If the curved section is not level, repeat steps 4c & 4d.  
g. Tighten the upper lock nut.
19. Tighten each of the three (3) stands to the custom frame.
20. For curved sections, install the wedge adjusters.  
See [Install a Wedge Adjust](#) on page 100.
21. Align the upper v-rails by adjusting the wedge or adjusting the screws on the inside of the curved section.  
See [Fine-Adjust the Upper V-Rail](#) on page 103.

22. Align the lower flat rails with the adjustment features mounted below the E-Turn plate.

See [Align a Flat Wear Strip](#) on page 241.

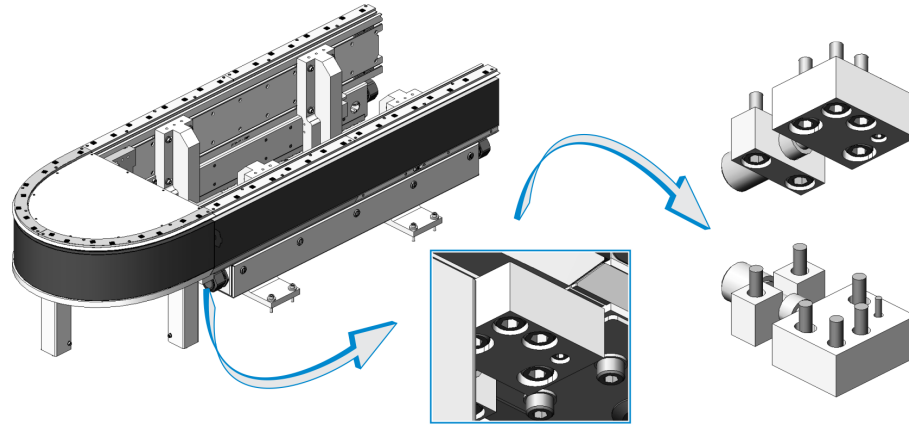

23. Repeat steps 16 to 22 for the second curved section.

24. Tighten the four (4) screws at the base of each straight section stand.

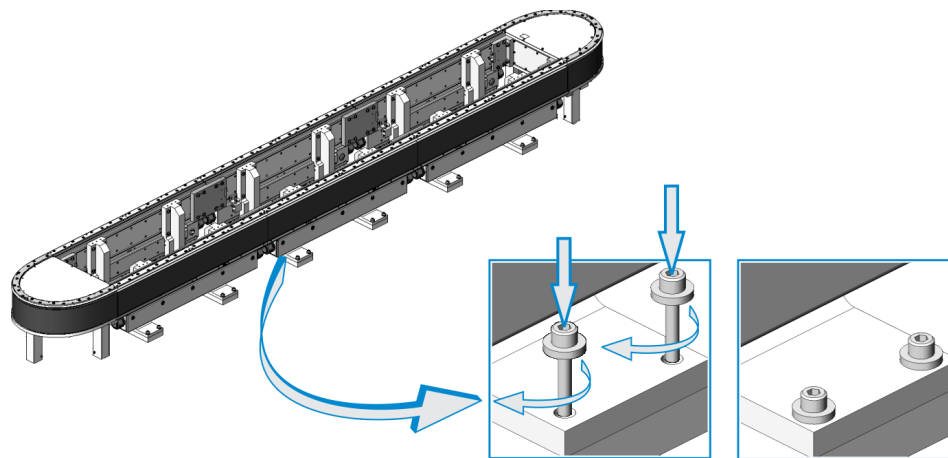

25. For 180 deg. (500 mm) sections only, reinstall the sections' top covers, and then reinstall the stand covers.

26. Install the lower flat wear strips.

See [Replace a Flat Wear Strip](#) on page 238.

27. Install the pallets.

See [Install a Pallet](#) on page 191.

28. If required, fine-adjust the upper v-rail.

See [Fine-Adjust the Upper V-Rail](#) on page 103.

## Install the SuperTrak Conveyance Platform in an Over/Under Configuration

**⚠ DANGER**

Always use appropriate lifting devices (for example, a forklift or crane) and use safe lifting practices and procedures when lifting a straight or curved section.

See [Lift a SuperTrak Conveyance Platform Section](#) on page 74.

ATS recommends that you obtain relevant information from your national Health and Safety Authority.

**NOTICE**

Make sure the frame is designed to hold the weight and force of the SuperTrak conveyance platform sections.



This procedure assumes that your frame includes the correct hole pattern on the top and sides of the frame.

See the SuperTrak conveyance platform *Mechanical Drawings* for additional information.

This section describes how to install SuperTrak conveyance platform in an over/under configuration.

1. Inspect the base plate to verify that it includes the correct features outlined in the SuperTrak conveyance platform *Mechanical Drawings*.

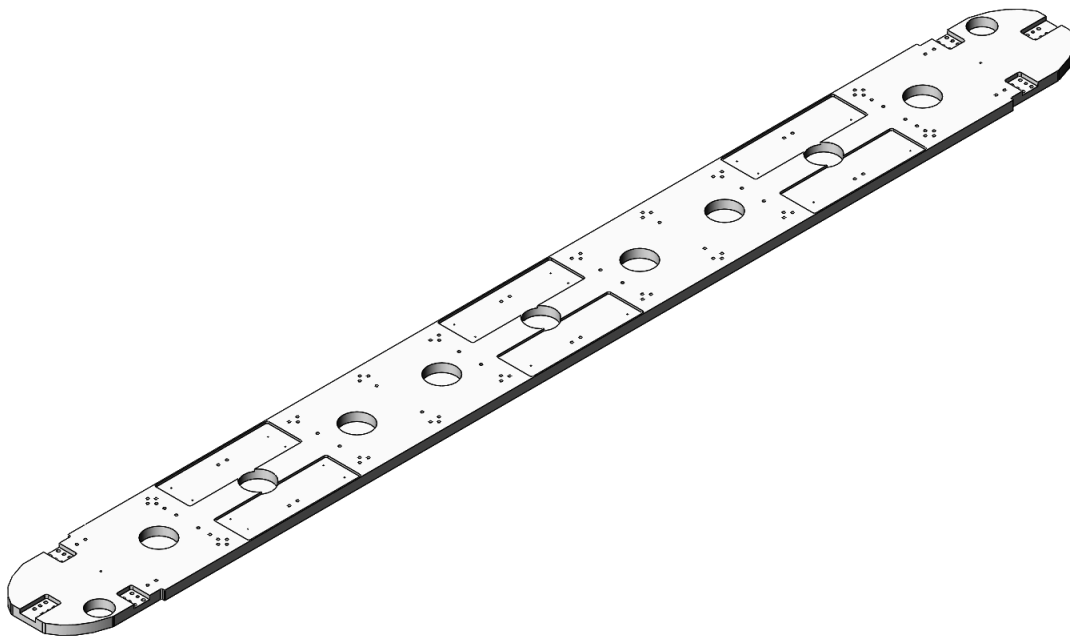

2. Position the base plate across two (2) or more metal saw horses, with the slotted cut-outs facing up.

3. Install the two (2) 180 deg. sections:
  - a. If not already attached, install three (3) mounting plates on the bottom of the 180 deg. sections with two (2) screws each.

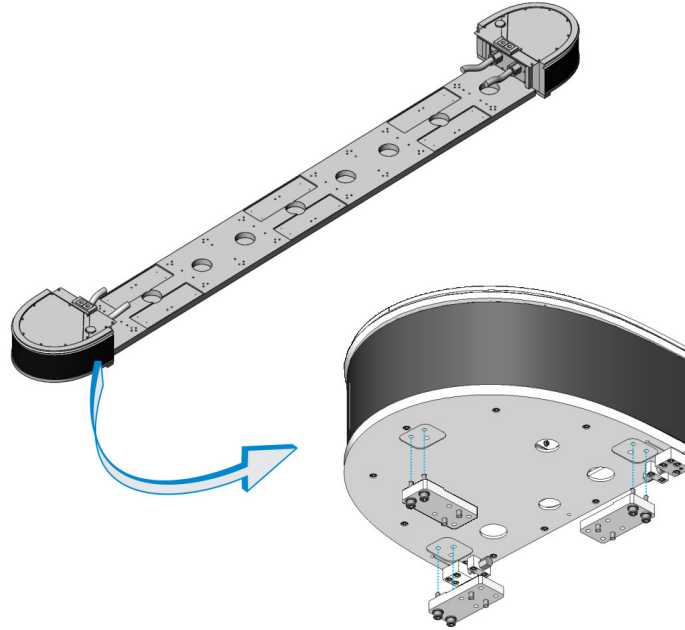

- b. Align the 180 deg. section with the base plate, and then secure with twelve (12) screws.

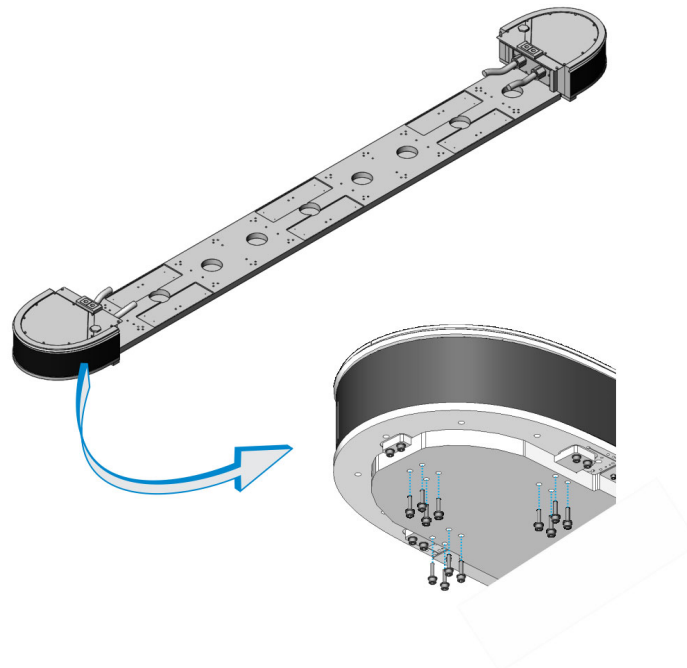

4. Mount the straight sections with their electrical boxes facing inwards, starting with the sections closest to the 180 deg. sections.

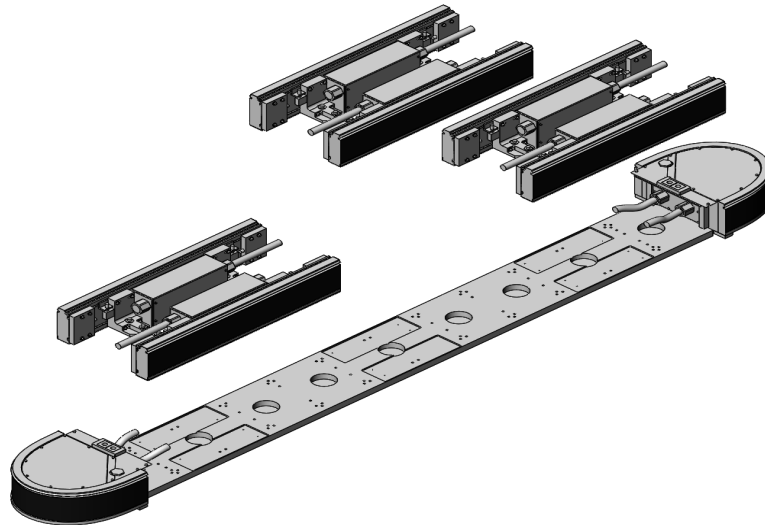

5. Loosely install four (4) screws into each straight section stand base. It is very important that the screws are centered in the screw holes as much as possible. This allows for adjustment when sections are connected together later.

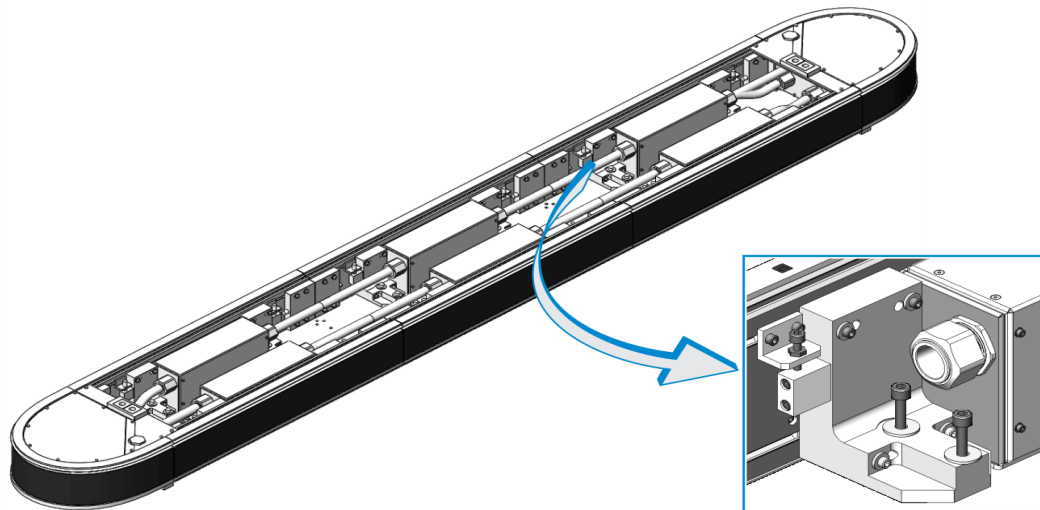

6. Verify that the following are aligned:

- Upper v-rails and flat wear strip pockets.

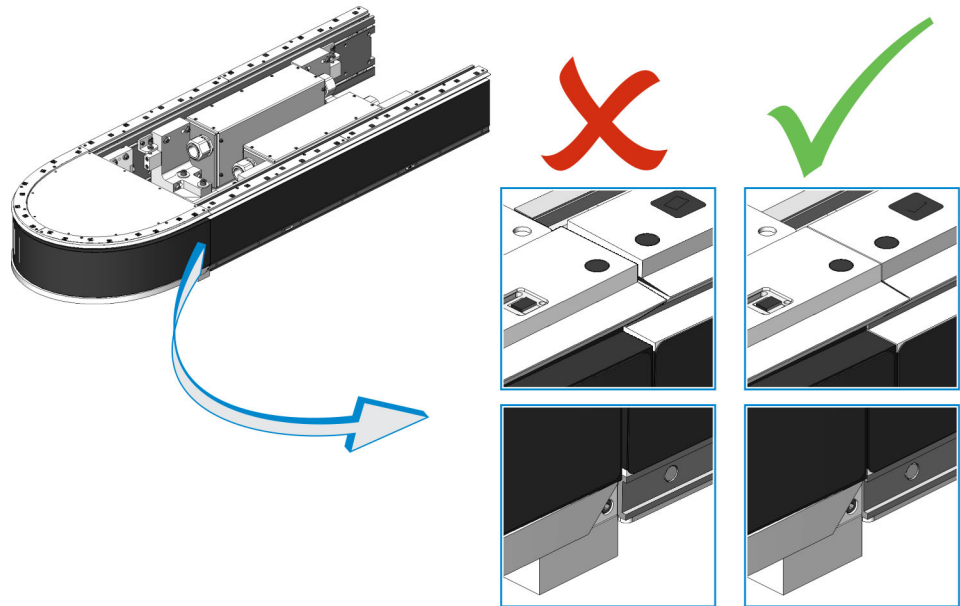

- Back of the laminations at all joints.

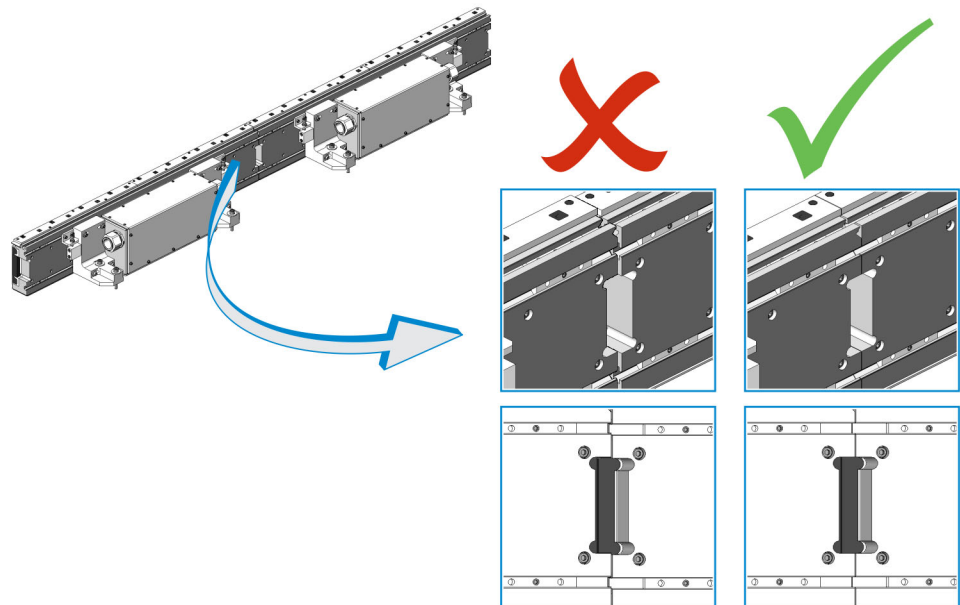

Fix any major misalignment before proceeding with fine alignment.

- Adjust the position of all sections until a 0.5 mm (0.02 in.) gap exists between all sections (between the track structure [or aluminum extrusion], not between the linear motors [or motor laminations]).

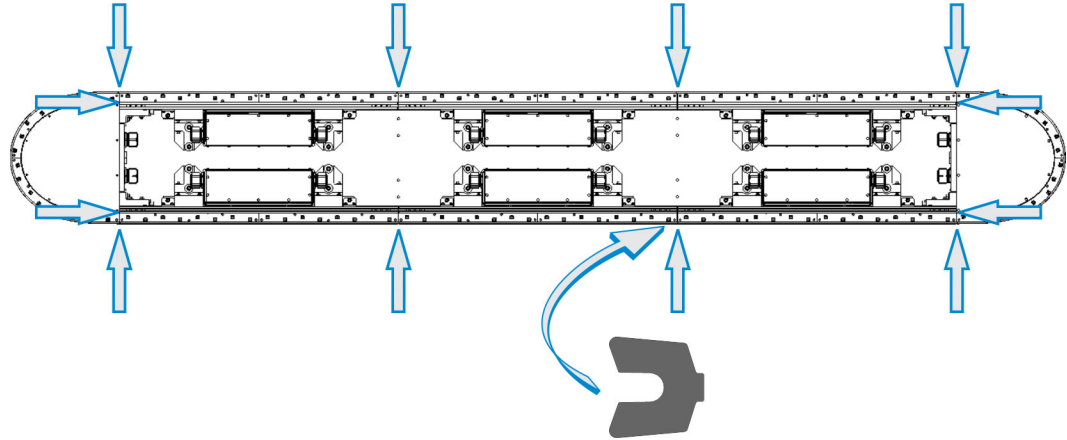

- Install the wedge adjust for the 180 deg. sections. Place the precision level on the t-slot behind the encoder assembly of the straight section when leveling.

See [Install a Wedge Adjust - 180 Deg. \(500 mm\) Section](#) on page 101.

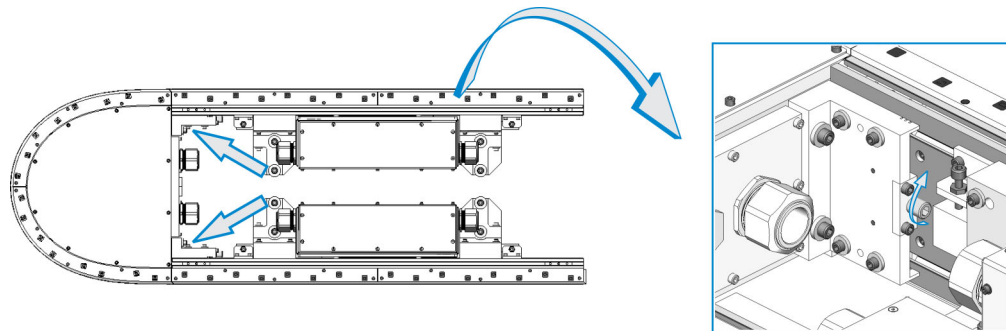



- Level the straight sections next to the 180 deg. sections.  
Place the precision level on the t-slot behind the encoder assembly of the straight section when leveling.

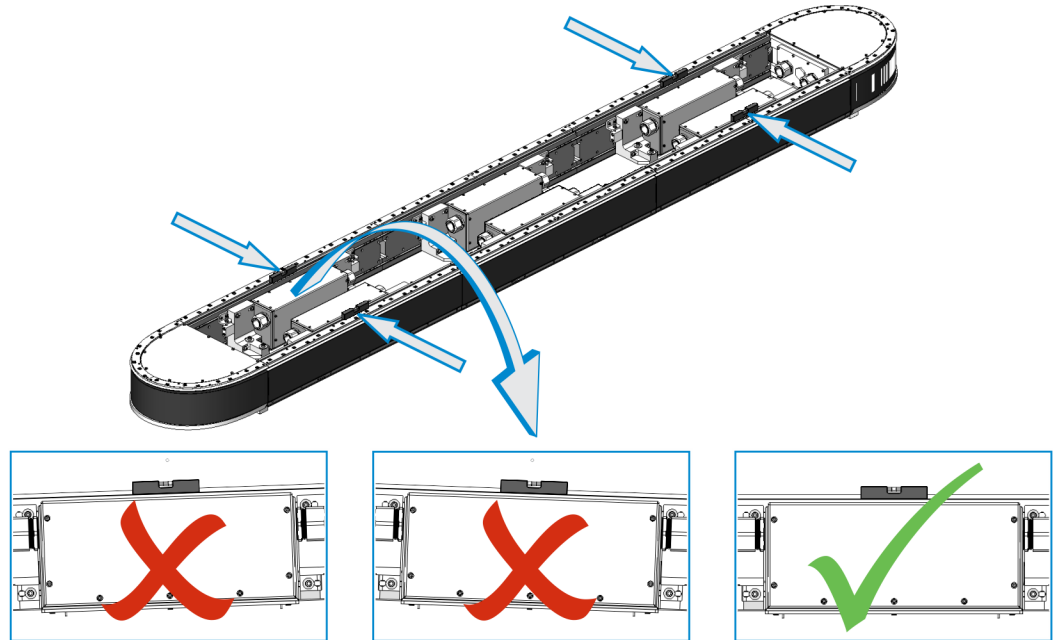

10. Level the straight sections in the middle of the track, and adjust them vertically to align the upper v-rails with the other straight sections.

See [Align the SuperTrak Conveyance Platform Section Joints](#) on page 98, and [Align the SuperTrak Conveyance Platform Section Heights](#) on page 99 for additional information.

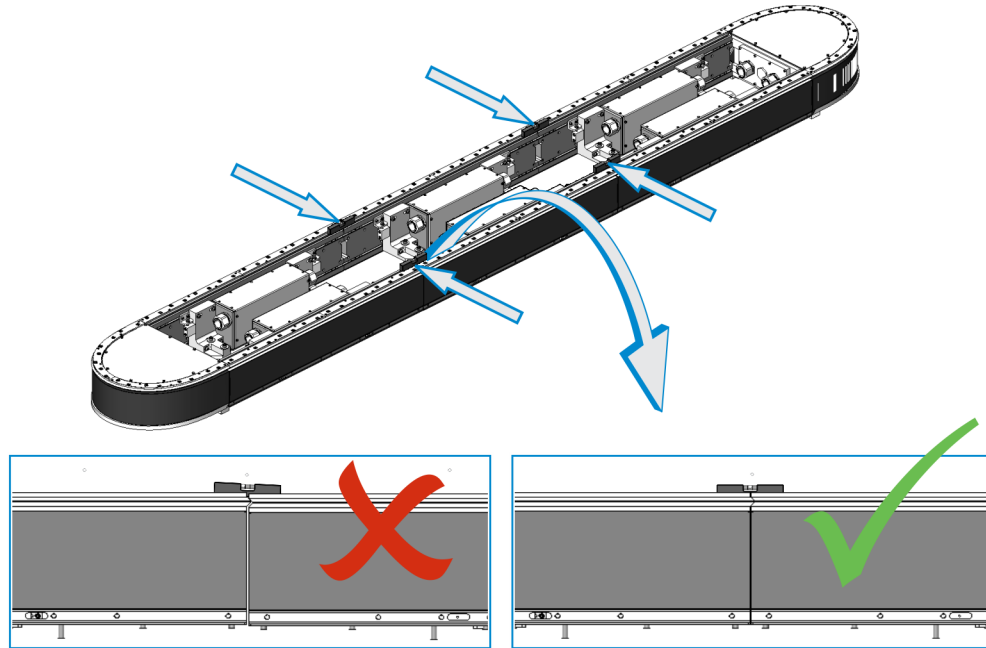

11. Install a wedge adjust between each of the straight sections.

See [Install a Wedge Adjust](#) on page 100.

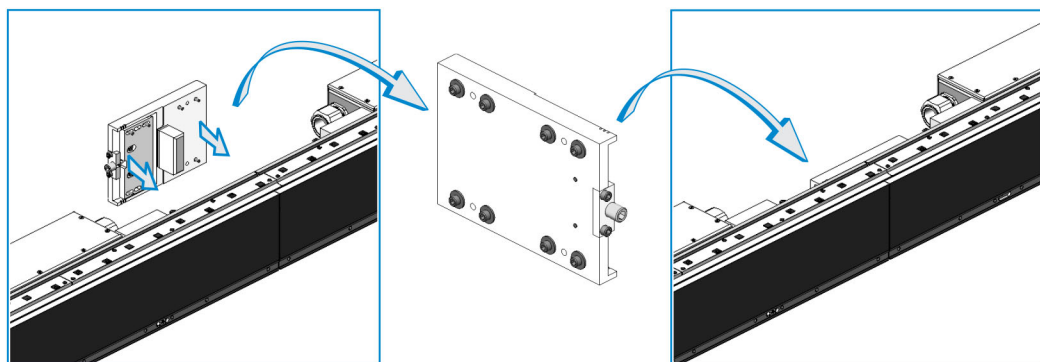

12. Adjust the wedges IN or OUT to align the upper v-rails. Only adjust when the wedge adjust screws are loose, and measure when the wedge adjust screws are tight.

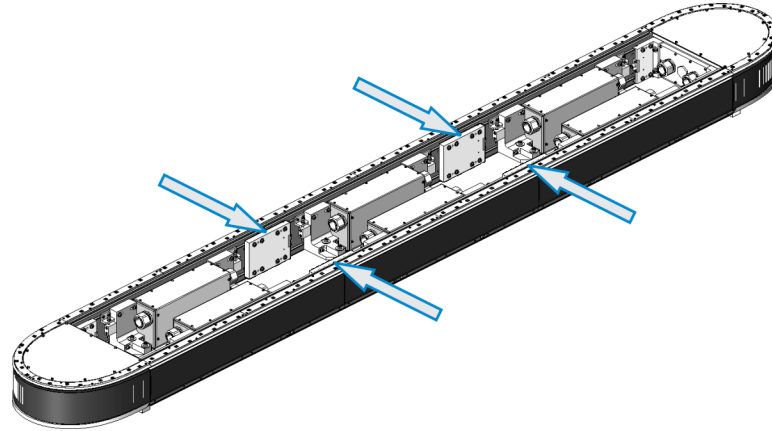

13. Align the upper v-rails by adjusting the wedge or adjusting the screws on the inside of the 180 deg. section.

See [Fine-Adjust the Upper V-Rail](#) on page 103.

14. Align the lower flat rails with the adjustment features mounted below the 180 deg. section.

See [Align a Flat Wear Strip](#) on page 192.

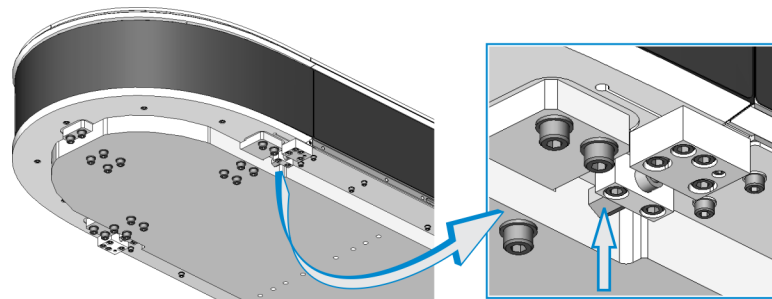

15. Tighten the four (4) screws in each straight section stand base.

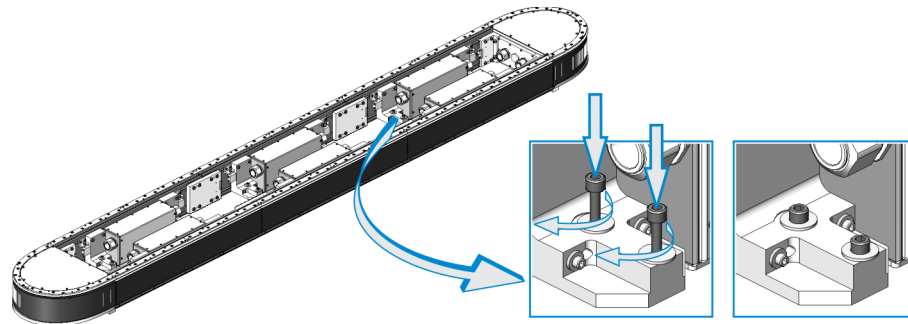

16. Add wear strip locators to straight sections with the tabs directed towards the center of the each section.

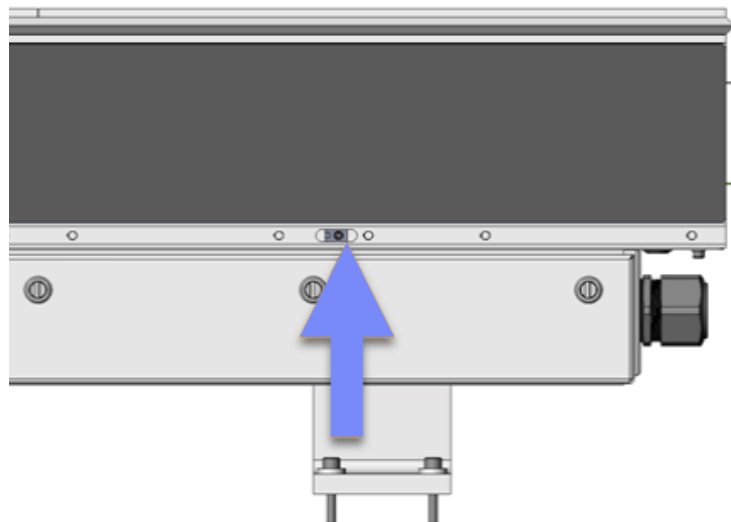

17. Install the wear strips to the straight sections.

See [Replace a Flat Wear Strip](#) on page 189.

*Note: If spacers were used between sections, remove those after installing wear strips.*

18. Add four (4) bolts to the bottom of each electrical box, making sure the grounding cables are secured to locations indicated by grounding symbol stickers.

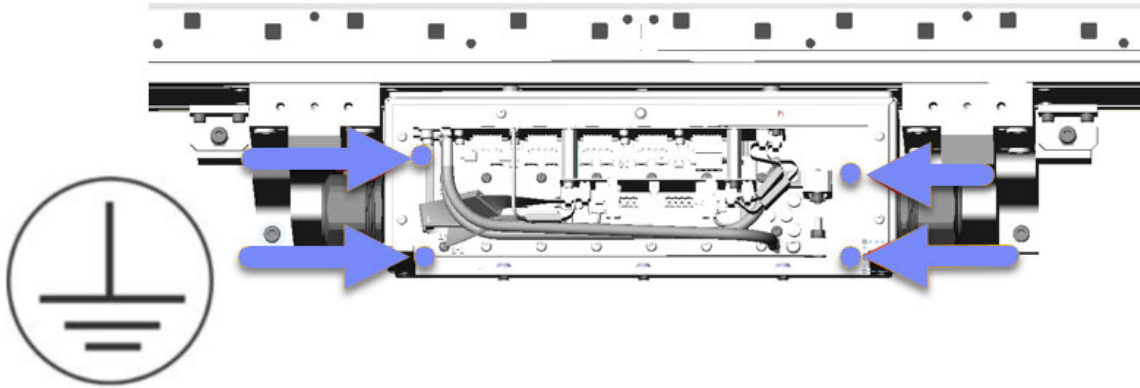

19. Lift the SuperTrak conveyance platform into position.  
Use correct lifting techniques with straps and a forklift.
20. Secure the base plate to the mounting frame.
21. Install the pallets.  
See [Install a Pallet](#) on page 147.
22. If required, fine-adjust the v-rails.  
See [Fine-Adjust the Upper V-Rail](#) on page 103.

## Lift a SuperTrak Conveyance Platform Section

** DANGER**

Always use appropriate lifting devices (for example, a forklift or crane) and use safe lifting practices and procedures when lifting a straight or curved section.

ATS recommends that you obtain relevant information from your national Health and Safety Authority.

This section describes the correct lifting techniques for the following:

- Straight section  
See [Lift a Straight Section Assembly](#) on page 75.
- 180 deg. section (500 mm)  
See [Lift a 180 Deg. Section \(500 mm\)](#) on page 76.
- 180 deg. section (800 mm)  
See [Lift a 180 Deg. Section \(800 mm\)](#) on page 77.
- Segments in an over/under configuration  
See [Lift a 180 Deg. Section \(800 mm\)](#) on page 77.

Always use appropriate lifting devices and use safe lifting practices when moving a section. The following tools are required for this procedure:

- Three (3) M8 rotating eye bolts



- Three (3) lifting straps, each with a minimum lifting capacity of 100 kg (220.5 lb)



- Appropriate lifting device (for example; a forklift or crane)

### Lift a Straight Section Assembly

1. Thread an M8 rotating eye bolt into the inner-most hole of each of the two (2) stands.

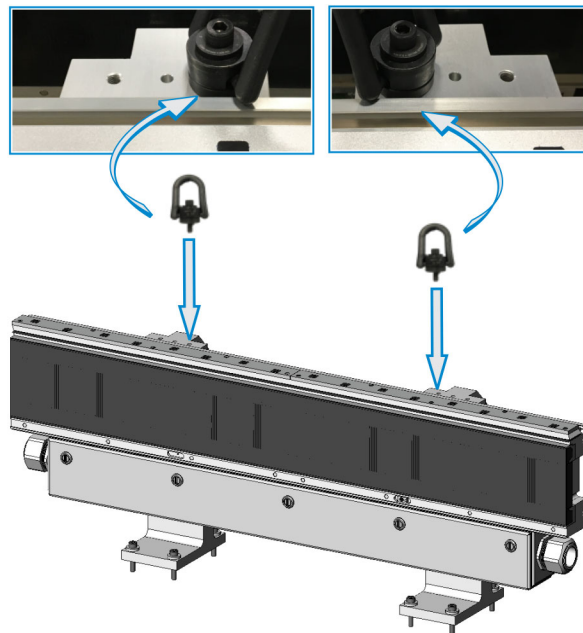

2. Attach each end of one (1) lifting strap to an eye bolt.

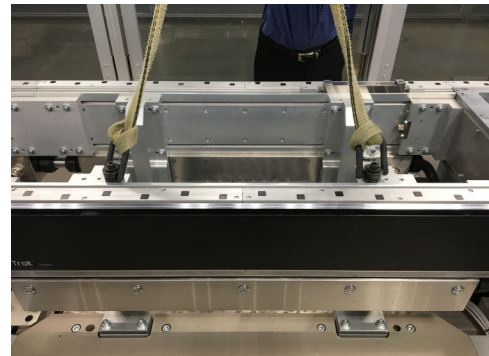

3. Use an appropriate lifting device, such as a forklift, to lift the straight section by the middle of the lifting strap.
4. When the straight section is in the required position, remove the lifting strap and two (2) eye bolts.

### Lift a 180 Deg. Section (500 mm)

1. Wrap one (1) strap around each of the three (3) stands.

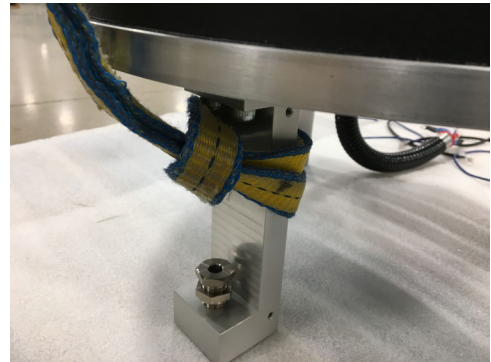

2. Use an appropriate lifting device, such as a forklift, to lift the 180 deg. section up by the ends of the lifting straps.

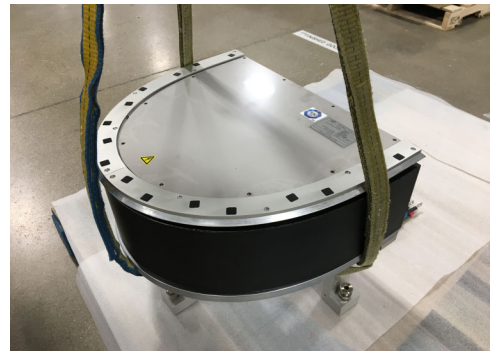

3. When the 180 deg. section is in the required position, remove the lifting straps.



**Lift a 180 Deg. Section (800 mm)**

1. Thread one (1) M8 rotating eye bolt into the top of each of the three (3) stands.

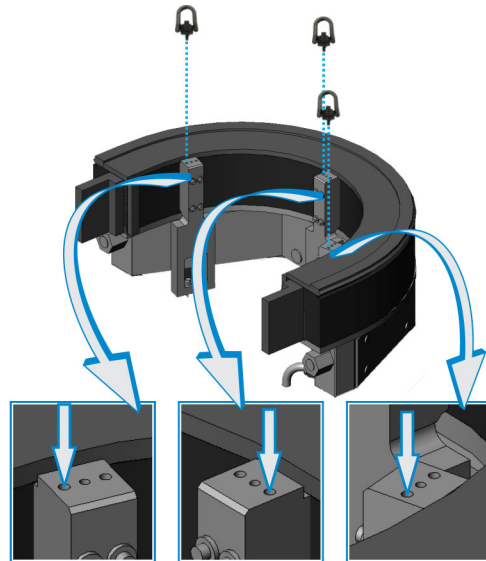

2. Attach one (1) strap to each of the three (3) M8 rotating eye bolts.



3. Use an appropriate lifting device, such as a forklift, to lift the 180 deg. section up by the ends of the lifting straps.
4. When the 180 deg. section is in the required position, remove the lifting straps.

### Lifting Segments in an Over-Under Configuration

Optional lifting brackets may be used for conveyors up to 4m long or for sections up to 5m with one e-turn. The brackets must be positioned to balance the load on each side of the brackets, and **a spreader bar must be used** so that the lifting force on the brackets is vertical.

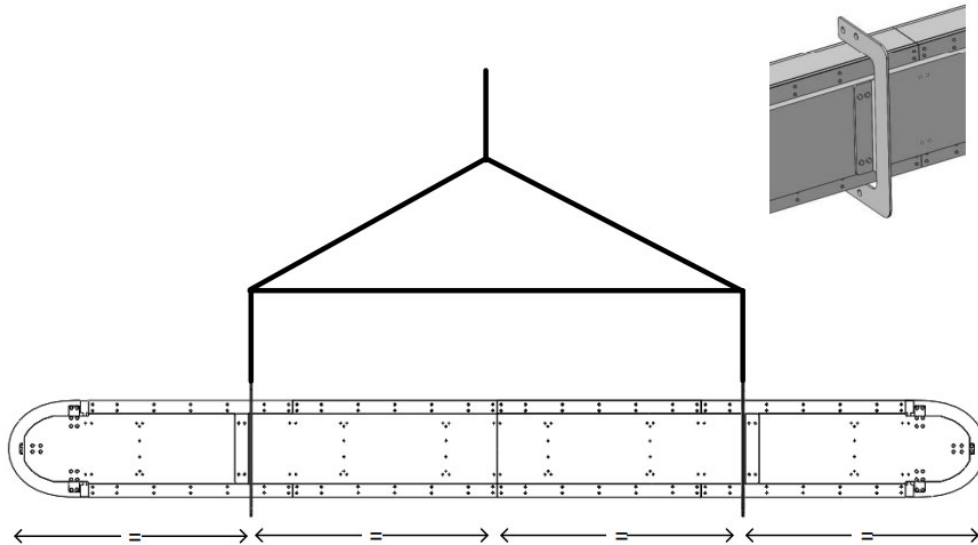

1. Remove from shipping box using the upper two holes on each lifting bracket. Use of a spreader bar is required.

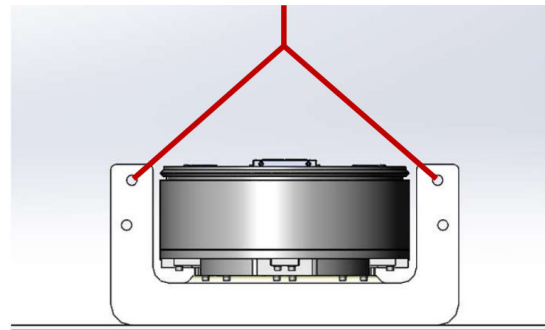

2. If required, reposition lifting brackets so that the mounting holes needed to attach the conveyor to the frame are accessible. Move shackle to the upper of the lifting holes on one side only.

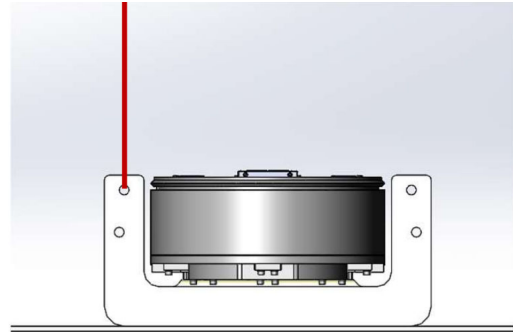

3. Lift so that the lower lifting hole is accessible.

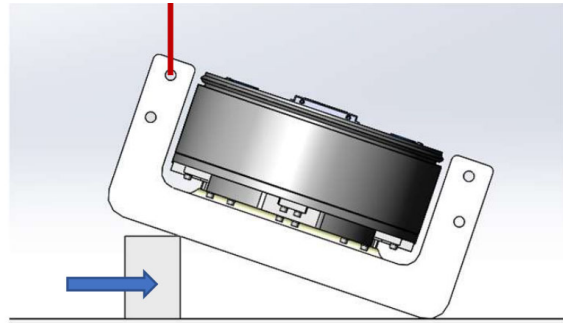

4. Move the shackle to the lower of the lifting holes as pictured.

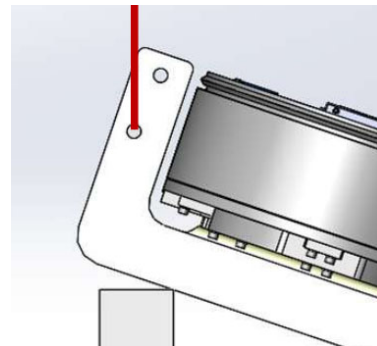

5. Lift into vertical position. As mentioned previously, use of a spreader bar is required.

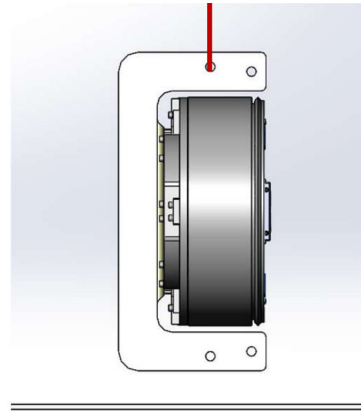

6. Once this change in orientation is complete, mount to frame and then remove lifting bracket (or store in the vertical orientation).

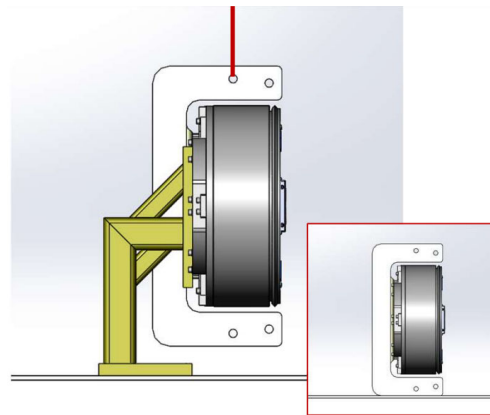

## Install a SuperTrak Conveyance Platform Section on a SuperTrak GEN3 Frame



Always use appropriate lifting devices (for example, a forklift or crane) and use safe lifting practices and procedures when lifting a straight or curved section.

See [Lift a SuperTrak Conveyance Platform Section](#) on page 74.

ATS recommends that you obtain relevant information from your national Health and Safety Authority.

This section describes how to install a straight or curved on a SuperTrak GEN3 frame.

### Install a Straight Section on a SuperTrak GEN3 Frame

1. Install the two (2) cross-braces on top of the frame:
  - a. Align a cross-brace with the frame holes.

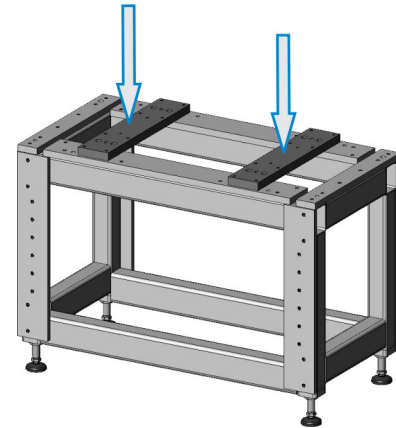

- b. Align a dowel pin with the cross-brace positioning hole. Make sure the threaded end is up.
  - c. Use a mallet to tap the dowel pin through the cross-brace hole and into the frame. The top of the dowel pin is slightly under the cross-brace surface when installed correctly.

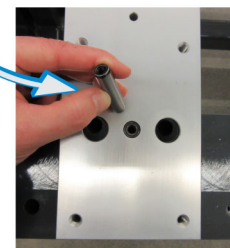
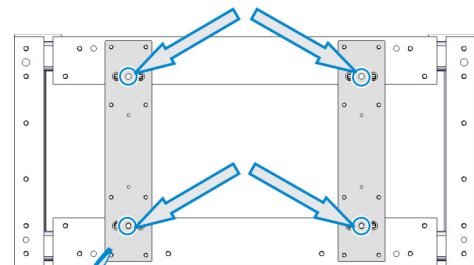

- d. Repeat step a to c for the second cross-brace.
- e. Secure the cross-brace in position with four (4) screws.

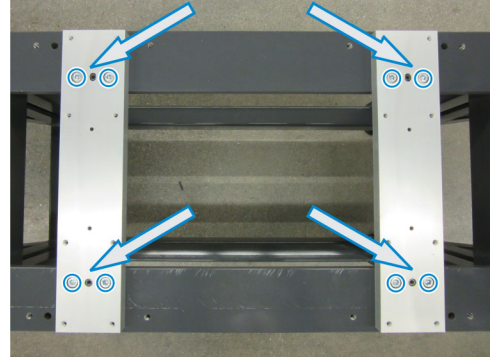

- f. Tap two (2) dowels halfway into the cross-brace. Make sure the dowel remains above the cross-brace surface.

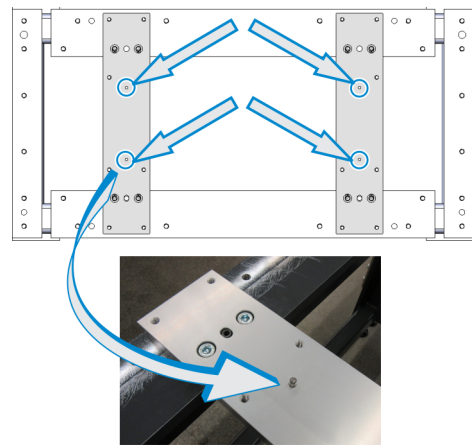

- g. Repeat steps a to f for the second cross-brace.

2. Install the first straight section on the frame:

- a. Lift and position a straight section on the frame.

Roughly center the straight section stands on the cross-braces. Make sure the straight section electrical box faces away from the frame.

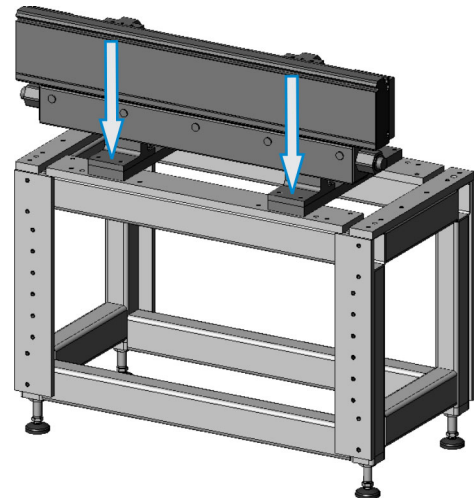

- b. Loosely install eight (8) screws into the stand bases.

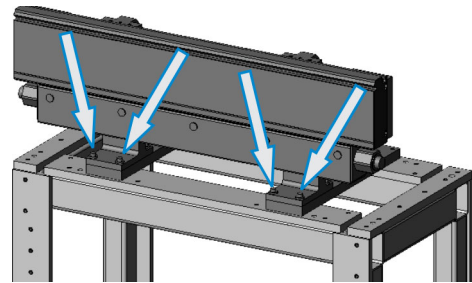

- c. Position a dowel pin between each straight section stand and the cross-brace dowel pins.

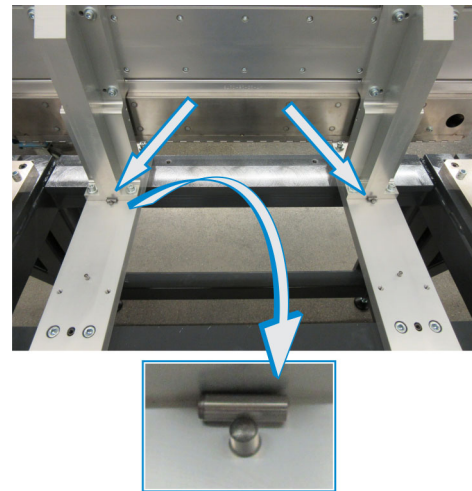

- d. Push the straight section toward the center of the frame, so it is tight against the dowel pins.

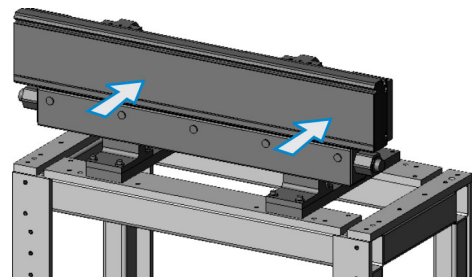

3. Repeat step 2 for the second straight section.
4. Check the alignment of the two (2) straight sections, by holding a square tight against the ends of the two (2) straight sections.

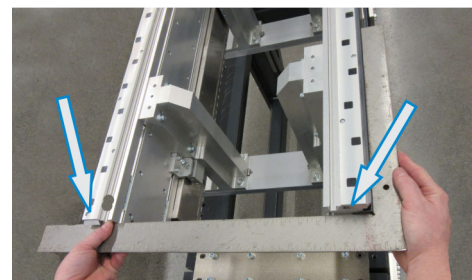

5. If the two (2) straight sections were not aligned in step 4, gently tap the straight section left or right (as required) until they are aligned.

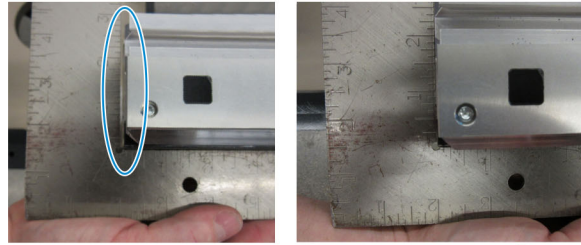
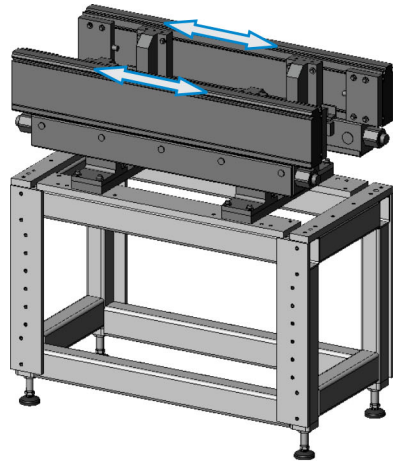

6. Tighten the four (4) screws at the base of each straight section stand.

It is very important that the screws are centered in the screw holes as much as possible. This allows for adjustment when sections are connected together later.

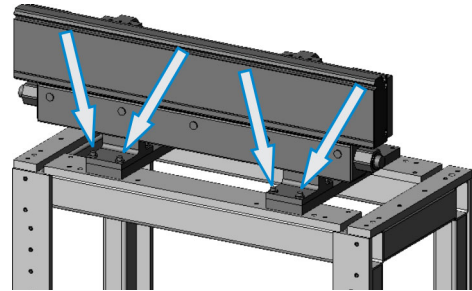



## Install a 180 Deg. Section (500 mm) on a SuperTrak GEN3 Frame

1. Install the 180 deg. plate on the frame:
  - a. Align the 180 deg. plate with the frame holes.
  - b. Install six (6) screws to secure the 180 deg. plate in position.

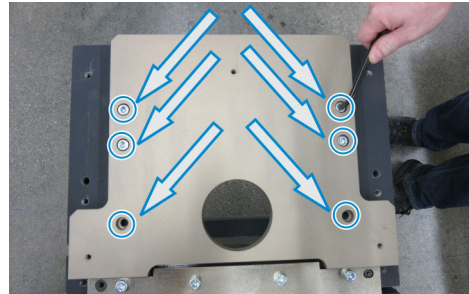

2. Lift and position a 180 deg. section on the 180 deg. plate.
3. Loosely install one (1) lock washer, and one (1) screw in each of the three (3) stand bases.

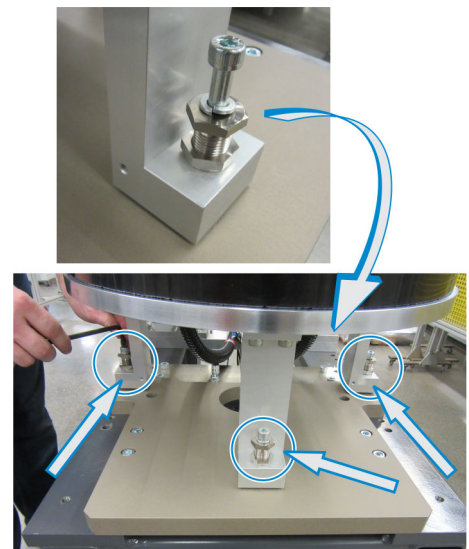

4. Level the 180 deg. section:
  - a. Place a precision spirit level across the frame in the directions illustrated, to determine the leveling foot (or feet) that requires adjustment.

For more precise measurements, remove the top cover from the 180 deg. section before leveling.

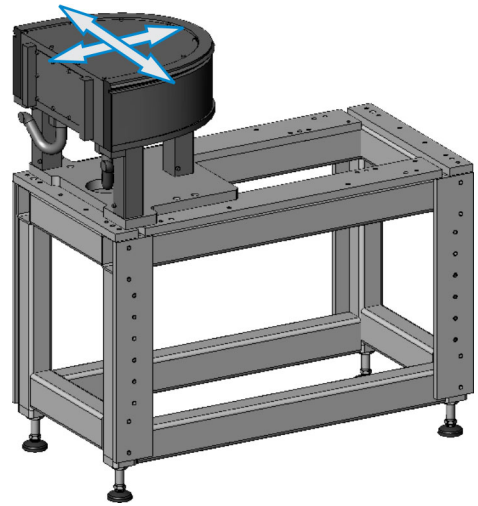

- b. Loosen the upper lock nut.
  - c. Turn the leveling screw as required, to raise or lower the side of the 180 deg. section.

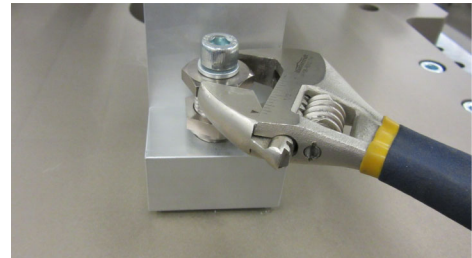

- d. Use a level to verify that the 180 deg. section is level.
    - e. If the 180 deg. section is not level, repeat steps c to d.
    - f. Tighten the upper lock nut.
5. Tighten the three (3) screws from step 3.

## Install a 180 Deg. Section (800 mm) on a SuperTrak GEN3 Frame

1. Install the 180 deg. (800 mm) plate on the frame:
  - a. Align the 180 deg. plate with the frame holes.

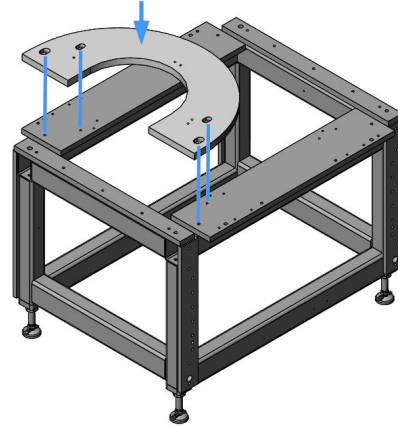

- b. Install four (4) screws to secure the 180 deg. plate in position.

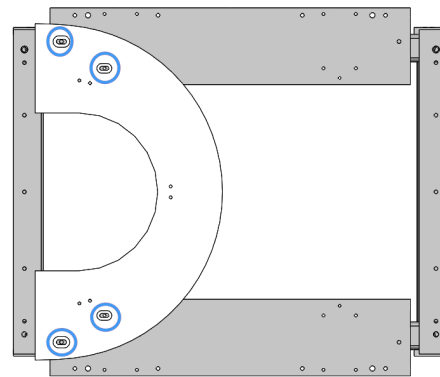

2. Lift and position a 180 deg. section on the 180 deg. plate.
3. Loosely install two (2) lock washers, and two (2) screws in each of the three (3) stand bases.

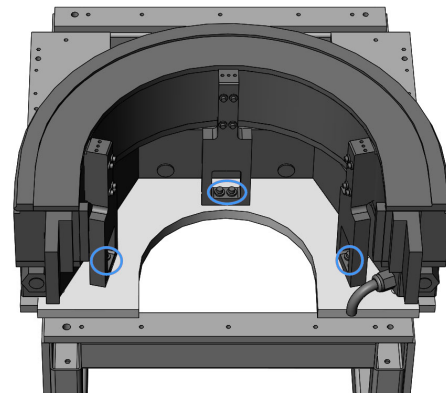

4. Level the 180 deg. section:
  - a. Place a precision spirit level across the frame in the directions illustrated, to determine the leveling foot (or feet) that requires adjustment.

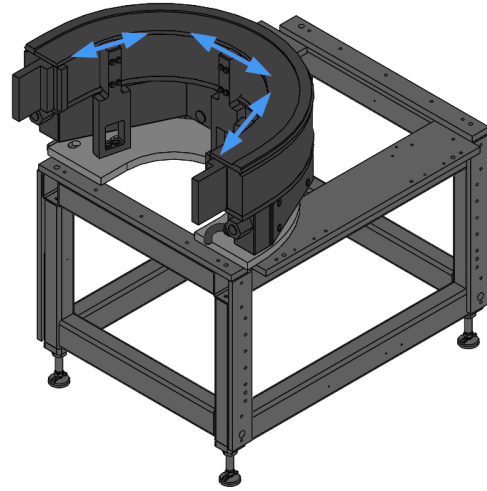

- b. Loosen the four (4) screws on each of the three stands.

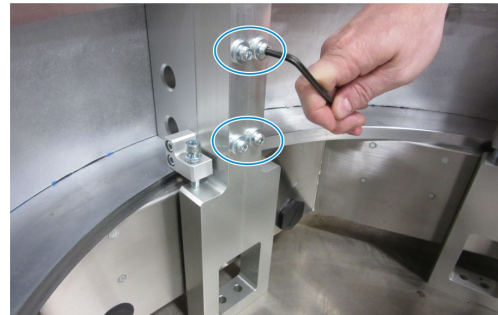

- c. Loosen the upper lock nut.
  - d. Turn the leveling screw as required, to raise or lower the side of the 180 deg. section.



- e. Use a level to verify that the 180 deg. section is level.
  - f. If the 180 deg. section is not level, repeat steps 4c to 4d.
  - g. Tighten the upper lock nut.
5. Tighten the twelve (12) screws from step 4b, and the six (6) screws from step 3.

## Install a 90 Deg. Section on a SuperTrak GEN3 Frame

1. Install the 90 deg. plate on the frame:
  - a. Align the 90 deg. plate with the frame holes.

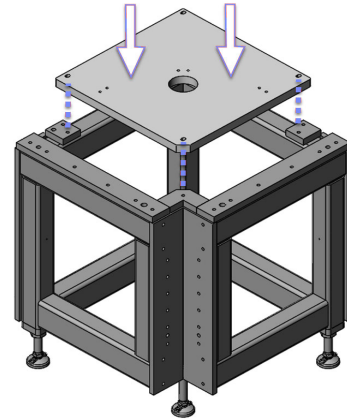

NOTE: When the overall conveyor arrangement is longer than it is wide, orient the mounting plates so that the slots align with the long axis of the conveyor.

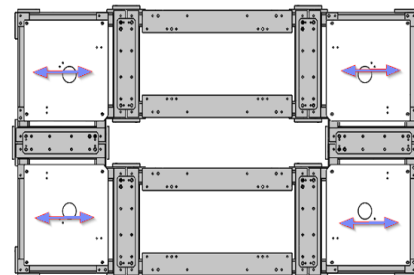

- b. Install four (4) screws to secure the 90 deg. plate in position.

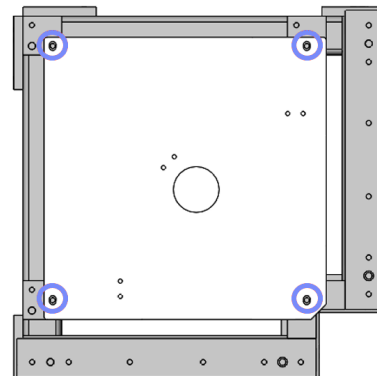

2. Lift and position a 90 deg. section on the 90 deg. plate.
3. Loosely install two (2) lock washers, and two (2) screws in each of the three (3) stand bases.

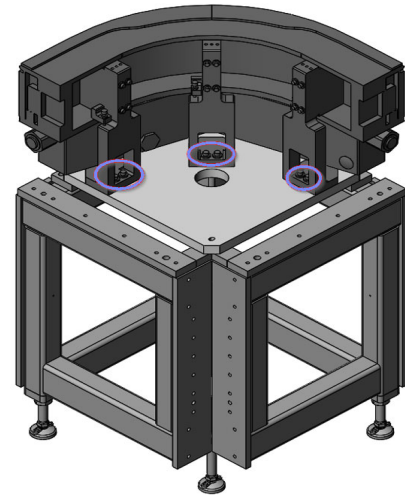

4. Level the 90 deg. section:
  - a. Place a precision spirit level across the frame in the directions illustrated, to determine the leveling foot (or feet) that requires adjustment.

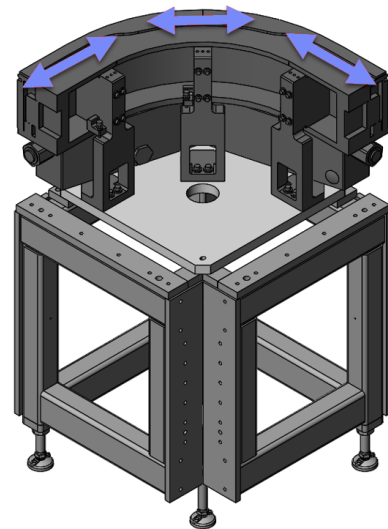

- b. Loosen the four (4) screws on each of the three stands.

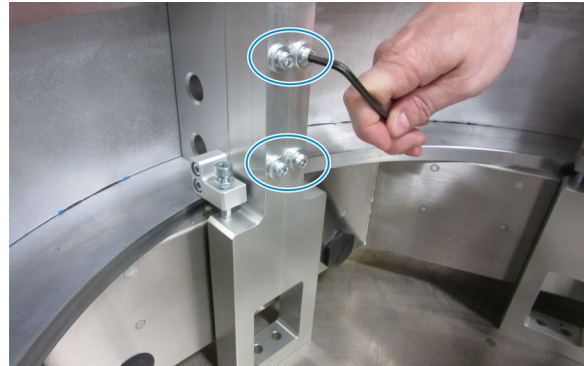

- c. Loosen the upper lock nut.
- d. Turn the leveling screw as required, to raise or lower the side of the 90 deg. section.



- e. Use a level to verify that the 90 deg. section is level.
  - f. If the 90 deg. section is not level, repeat steps 4c to 4d.
  - g. Tighten the upper lock nut.
5. Tighten the twelve (12) screws from step 4b, and the six (6) screws from step 3.

## Install the First SuperTrak Conveyance Platform Section

**DANGER**

Always use appropriate lifting devices (for example, a forklift or crane) and use safe lifting practices and procedures when lifting a straight or curved section.

See [Lift a SuperTrak Conveyance Platform Section](#) on page 74.

ATS recommends that you obtain relevant information from your national Health and Safety Authority.

**NOTICE**

To prevent system damage, keep the system sections upright at all times.



During installation, consider the size of the system. For large systems (>7 sections) install the middle straight section first and work your way out to each 180 deg. section. For small systems (<7 sections), installation can begin from the far left or right 180 deg. section.

In this procedure, "section A" references an installed straight section, 180 deg. section, or group of sections.

1. Position section A in the installation location.

Make sure the installation location has a non-compressing floor (for example; concrete), to correctly level and align section A.

2. Level the frame.

See [Level the Frame](#) on page 95.

3. Place a precision spirit level across the top of section A in the directions illustrated, to determine if additional adjustment is required.

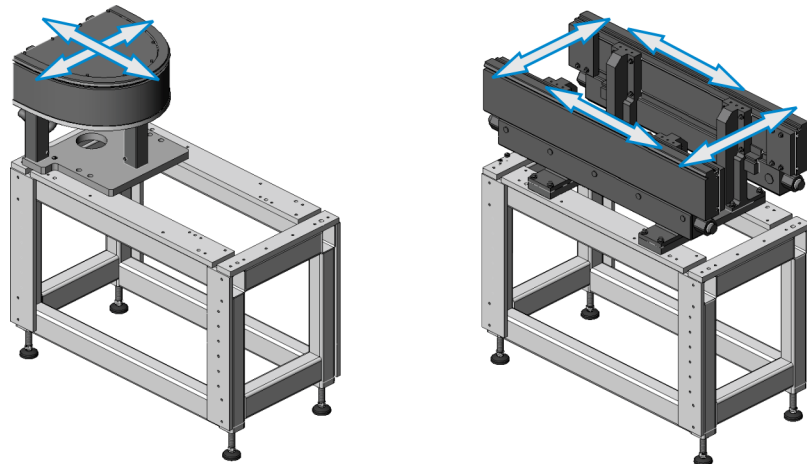



If the section is not level, adjust the required leveling screw.

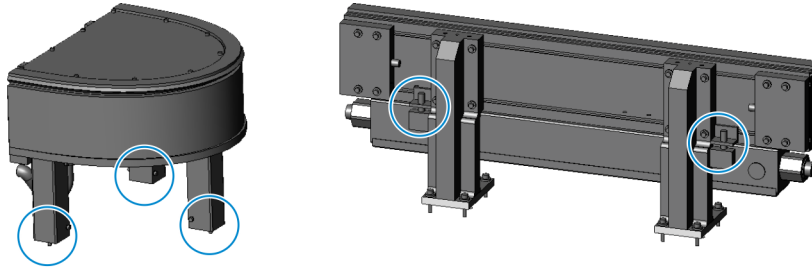

4. Install two (2) dowels through the outer holes of top connection plate, to position the top connection plate on the frame.

The top connection plate for the 180 deg. section is notched; the straight section connection plate is not notched.

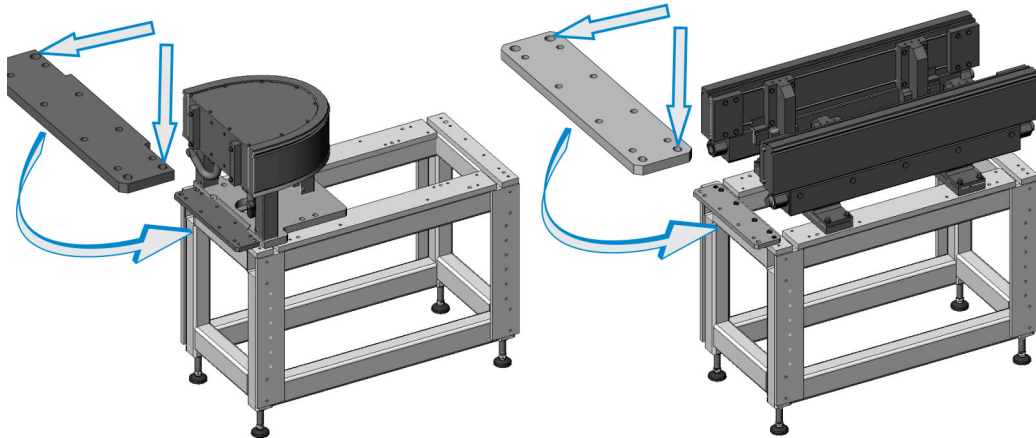

**NOTE:** If you are using compact frames to support 180 deg sections, use the supplied stepped dowels to attach the connector kit to the joint between the compact frame and the one-meter section frame, as pictured.

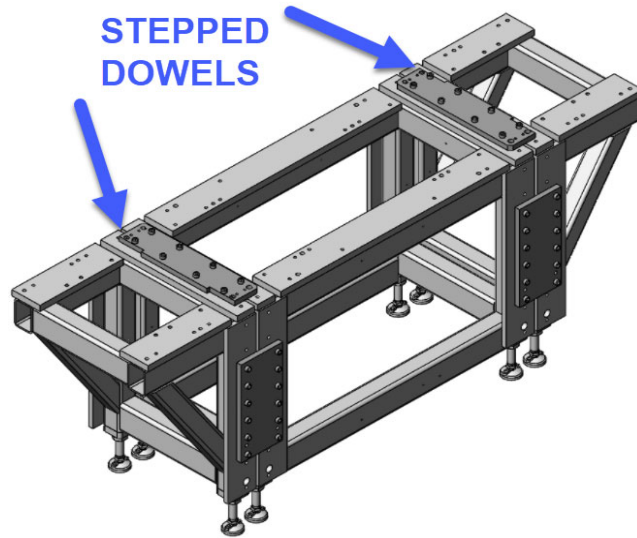

5. Install four (4) screws in the top connection plate to secure it in position.

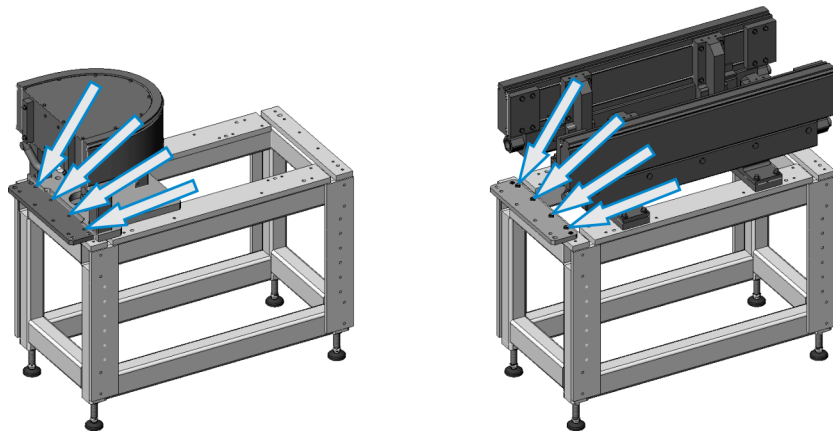

## Level the Frame

To accommodate varying floor heights, the leveling feet of the SuperTrak conveyance platform frame allow for individual height adjustment.

1. Place a precision spirit level across the frame in the directions illustrated, to determine the leveling foot (or feet) that requires adjustment.

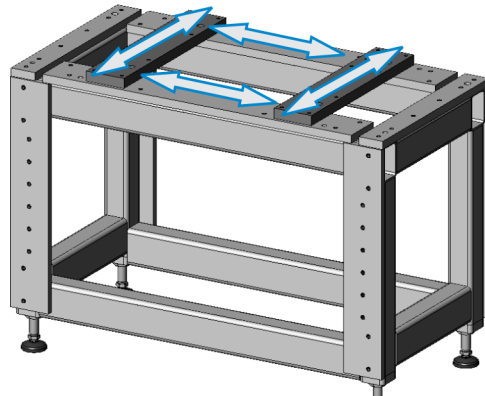

2. If installed, remove the anchor bolt and hold down toe.

<b>A</b>	Hold down toe
<b>B</b>	Anchor bolt and washer
<b>C</b>	Frame
<b>D</b>	Upper lock nut
<b>E</b>	Lower lock nut
<b>F</b>	Leveling foot

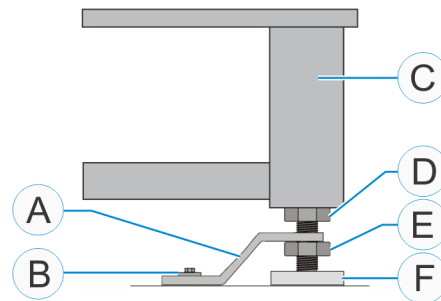

3. Loosen the upper lock nut.
4. Turn the leveling foot as required, to raise or lower the table.
5. Use a level to verify that the table is level.
6. If the frame is not level, repeat steps 1 to 5.
7. Tighten the upper lock nut.
8. If required, install the hold down toe over the lower lock nut.
9. Tighten the anchor bolt.

## Connect Two SuperTrak Conveyance Platform Sections Together

**DANGER**

Always use appropriate lifting devices (for example, a forklift or crane) and use safe lifting practices and procedures when lifting a straight or curved section.

See [Lift a SuperTrak Conveyance Platform Section](#) on page 74.

ATS recommends that you obtain relevant information from your national Health and Safety Authority.

**NOTICE**

- To prevent system damage, always keep the system sections upright.
- When two (2) large SuperTrak conveyance platform sections are joined together, remove the upper v-rail from the connecting straight sections.

The upper v-rail overhangs the edge of the section; removal of the upper v-rail before joining the sections prevents upper v-rail and encoder assembly damage.

It is also recommended to install the interconnect before the sections are joined together, for ease of installation.

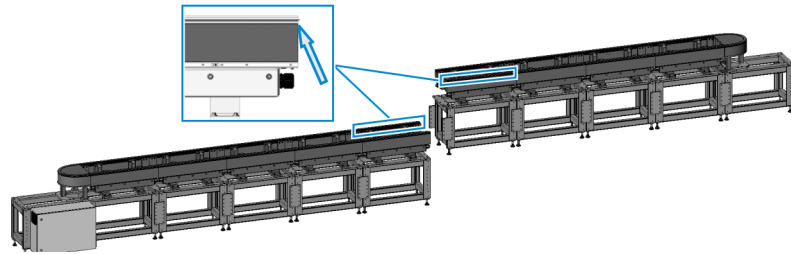

In this procedure, “section A” references an installed straight section, 180 deg. section, or group of sections. “Section B” is the straight section, 180 deg. section, or group of sections being installed next to section A.

1. Align the section B with the section A, and then slide the section B under the top connection plate of section A.
2. If required, adjust the height of section B until the top of the frame touches the bottom of the top connection plate on section A.
3. Install two (2) dowels through the outer holes of top connection plate.
4. Level section B.  
See [Level the Frame](#) on page 95.
5. Loosely install four (4) screws in the top connection plate to secure section B in position.

6. Loosely connect the sides of the frames together. Install a side connection plate on each side of the frame with twelve (12) screws in each.

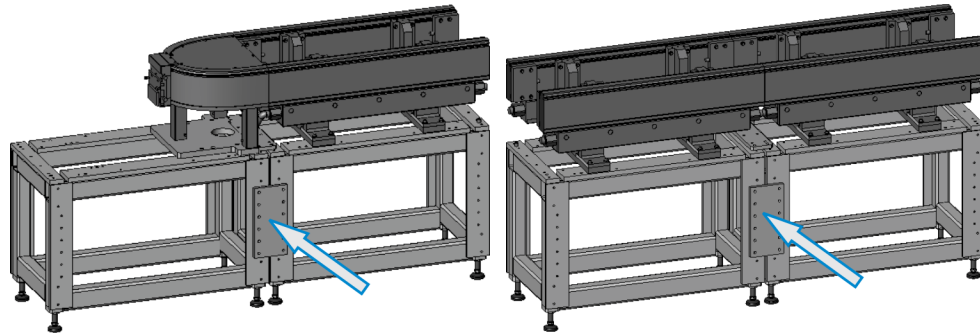

7. Use a 0.5 mm (0.02 in.) shim to verify that a 0.5 mm (0.02 in.) space exists between the aluminum surfaces of section A and section B.

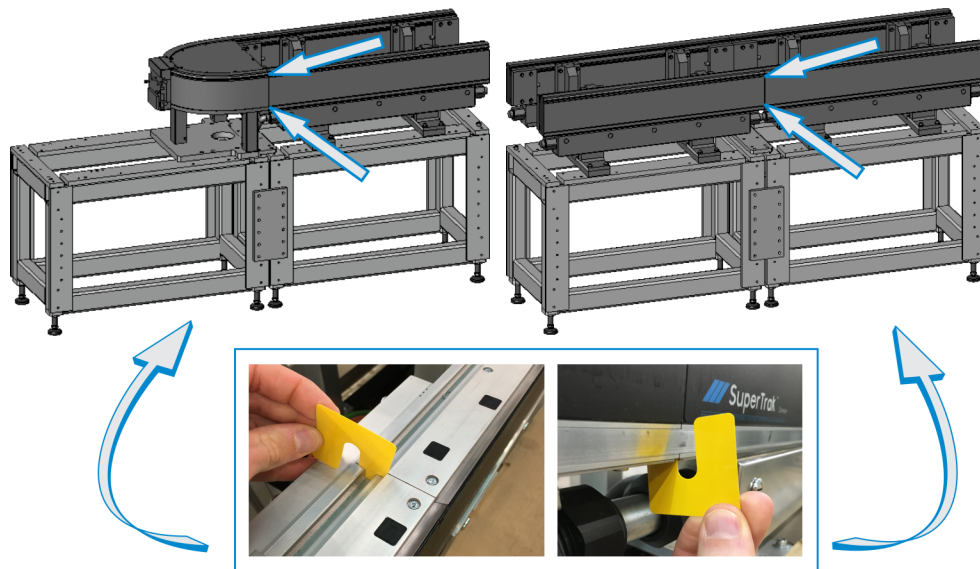

8. Tighten the four (4) screws from step 5.
9. Tighten the twenty-four (24) screws from step 6.

## Align the SuperTrak Conveyance Platform Section Joints

1. In the recess where the motor laminations meet, verify that the laminations align.

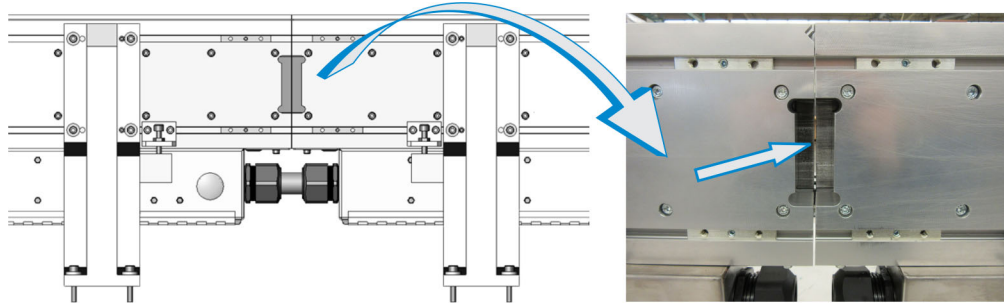

The image below provides a top view of two straight sections that are not aligned.

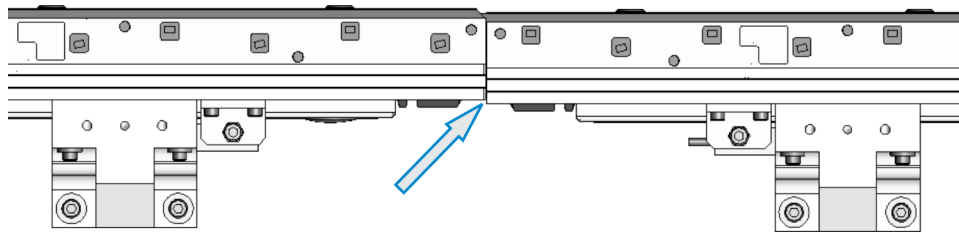

2. If the joints are not aligned:
  - a. Loosen the four (4) screws on the base of the stand that requires adjustment.

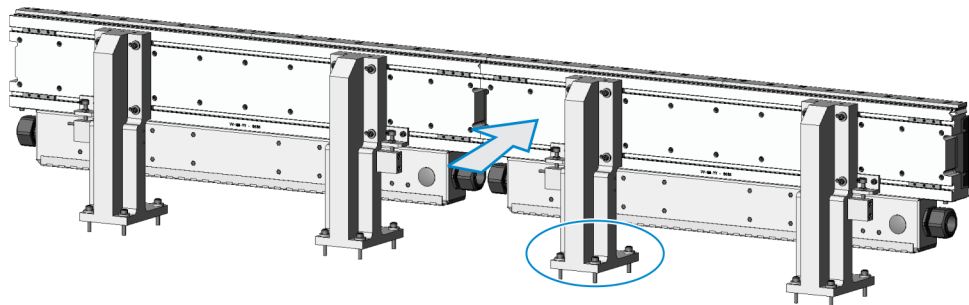

- b. Gently slide the section forward or back until the sections are aligned.
  - c. Tighten the four (4) screws from step a.
  - d. Repeat step 1.

## Align the SuperTrak Conveyance Platform Section Heights

1. At the upper v-rail joint, measure the offset between the two (2) upper v-rails. If the offset exceeds  $\pm 0.07$  mm (0.0027 in.), the SuperTrak conveyance platform sections are not aligned.

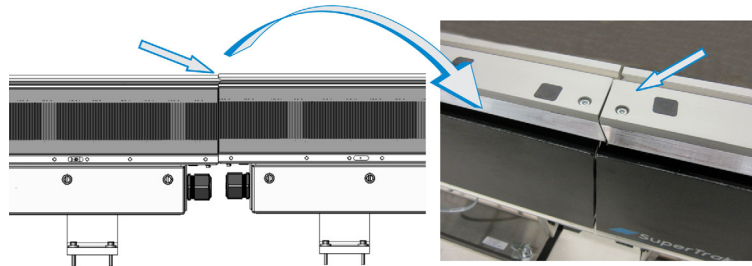

The image below illustrates a possible validation process, where two (2) indicators are mounted to a pallet to measure the offset between the two (2) upper v-rails.

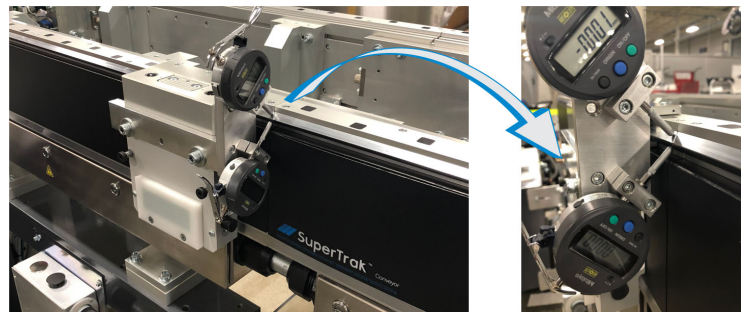

2. If the height is not aligned:
  - a. Loosen the four (4) screws on the top of the stand that requires adjustment.
  - b. Adjust the height adjustment screw up or down until the height is aligned.

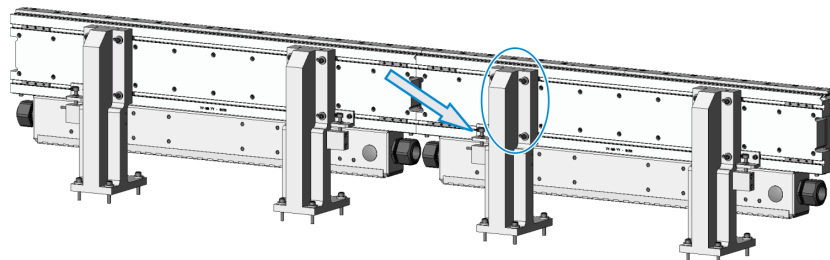

- c. Tighten the four (4) screws from step a.
  - d. Repeat step 1.

## Install a Wedge Adjust

The wedge adjust compensates for excess tolerance between SuperTrak conveyance platform sections.

### Install a Wedge Adjust - Straight Section

1. Verify that the edge of the wedge adjust plate aligns with the center notch on the side of the wedge adjust. If required, turn the adjustment knob to obtain the correct position.

Make sure that the foam piece is adhered to the wedge adjust, as shown in the photo.

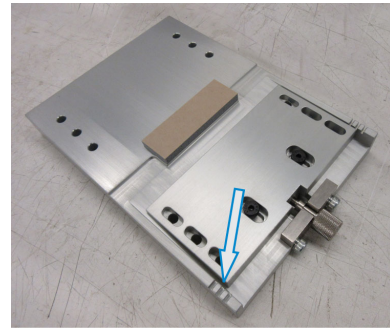

2. Place the magnetic shunt into the opening between the two (2) straight sections.

(The magnetic shunt is an iron block that improves the continuity of the magnetic field for shuttle attraction. It has no mechanical alignment purpose.)

Do not place any objects in the opening before the magnetic shunt is inserted. The magnetic shunt requires iron-to-iron contact with the motor core of each straight section.

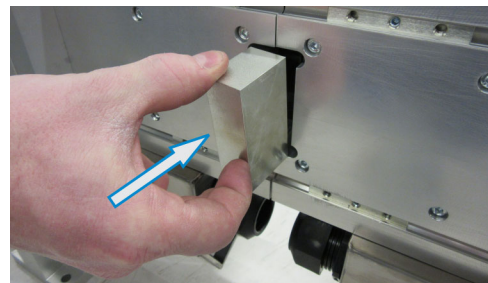

3. Align the wedge across two (2) straight sections.

Make sure the wedge holes align with the on the t-bars in the t-slot.



4. Loosely install eight (8) washers and eight (8) screws to install the wedge to the t-bars.
5. Tighten the four (4) screws on the non-adjustable side of the wedge.

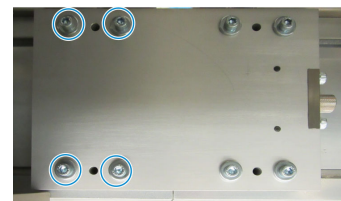



## Install a Wedge Adjust - 180 Deg. (500 mm) Section

1. Verify that the edge of the wedge adjust plate aligns with the center notch on the side of the wedge adjust. If required, turn the adjustment knob to obtain the correct position.

Also make sure that the foam piece is adhered to the wedge adjust as shown in the photo.

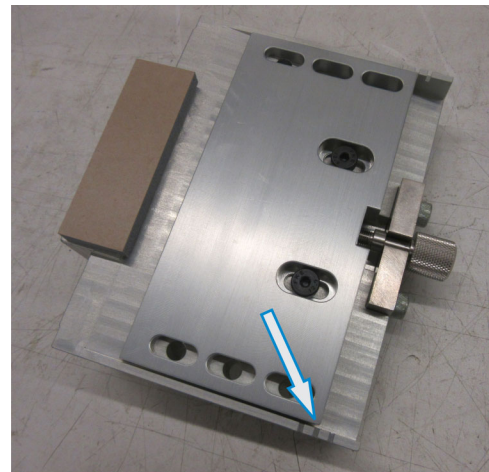

2. Place the magnetic shunt into the opening between the two (2) SuperTrak conveyance platform sections.

(The magnetic shunt is an iron block that improves the continuity of the magnetic field for shuttle attraction. It has no mechanical alignment purpose.)

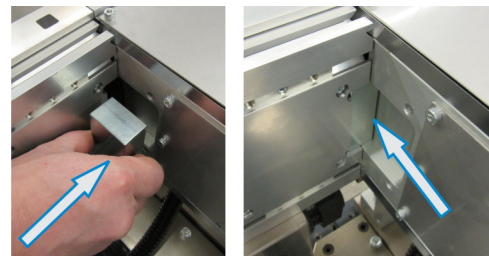

Slide the magnetic shunt into the opening width-wise, and then push it sideways into location. Do not place any objects in the opening before the magnetic shunt is inserted. The magnetic shunt requires iron-to-iron contact with the motor core of both the straight section and the 180 deg. section.

3. Align the wedge adjust across the straight section and a 180 deg. section.

The end of the wedge adjust slides into the opening that was used for the magnetic shunt installation.

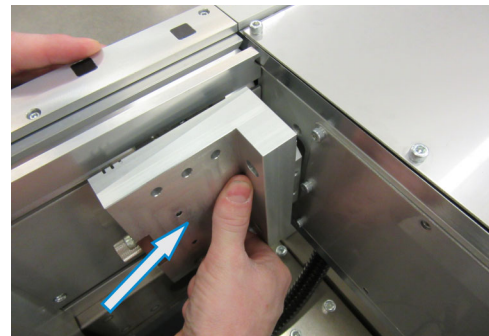

- Loosely install four (4) washers and four (4) screws on the straight section side, and then install and tighten two (2) washers and two (2) screws on the side of the 180 deg. section.

Note that the screws installed on the 180 deg. section are larger.



## Fine-Adjust the Upper V-Rail

**NOTICE**

The maximum vertical tolerance at the upper v-rail joint is 70 µm.



Upper v-rail alignment is an iterative process. Alternate between height and wedge adjustments until the upper v-rail is flush and the sound is consistent when a pallet is pushed past the upper v-rail joint.

Fine-adjust the upper v-rail if the pallets make significant noise when traveling over the upper v-rails. This diagram indicates the location of the components that are referenced in this procedure.

<b>A</b>	Upper v-rail joint
<b>B</b>	Wedge adjust
<b>C</b>	Stand
<b>D</b>	Wedge adjustment knob
<b>E</b>	Height adjustment

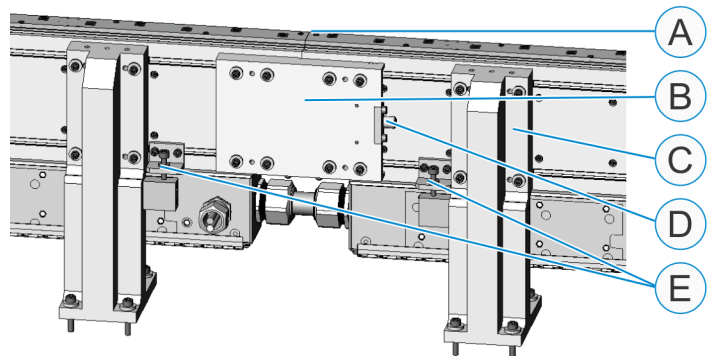

1. Verify that all stand and wedge screws are tight.
2. Complete one (1) of the following:
  - Run your finger over the upper v-rail joint.
  - Manually slide a pallet across the upper v-rail joint in both directions while you watch and listen to the pallet.
3. If you feel a ridge, or if the pallet makes any knocking sounds as it rolls over the upper v-rail joint, proceed to step 4; otherwise, the procedure is complete.
4. Determine which section is higher and by how much, and then complete one (1) of the following:
  - If the upper v-rail requires  $\pm 0.05$  mm ( $\pm 0.002$  in.) adjustment, see [Adjust the Upper V-Rail  \$\pm 0.05\$  mm \( \$\pm 0.002\$  in.\) - Straight Section to Straight Section](#) on page 104.
  - If the upper v-rail requires  $> \pm 0.05$  mm ( $> \pm 0.002$  in.) adjustment, see [Specialized Upper V-Rail Adjustment - Straight Section to Straight Section](#) on page 108.

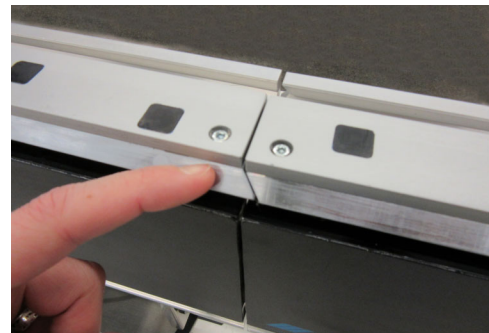

### Adjust the Upper V-Rail $\pm 0.05$ mm ( $\pm 0.002$ in.) - Straight Section to Straight Section

1. If vertical upper v-rail adjustment is required, complete the following steps on the side that requires adjustment:
  - a. Loosen the four (4) screws at the top of the stand.

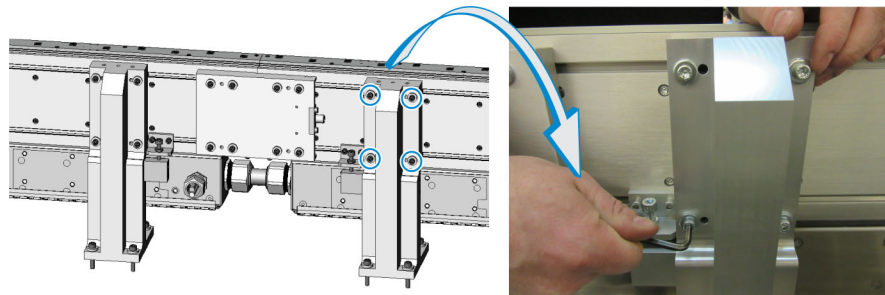

- b. Loosen the four (4) wedge screws.

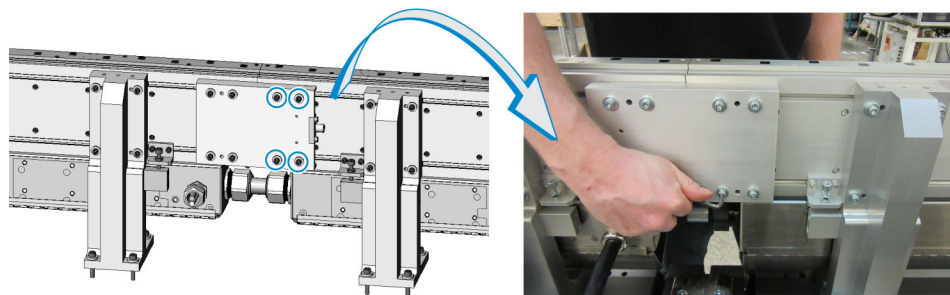

- c. Turn the height adjustment screw as required to adjust the upper v-rail height (UP or DOWN).

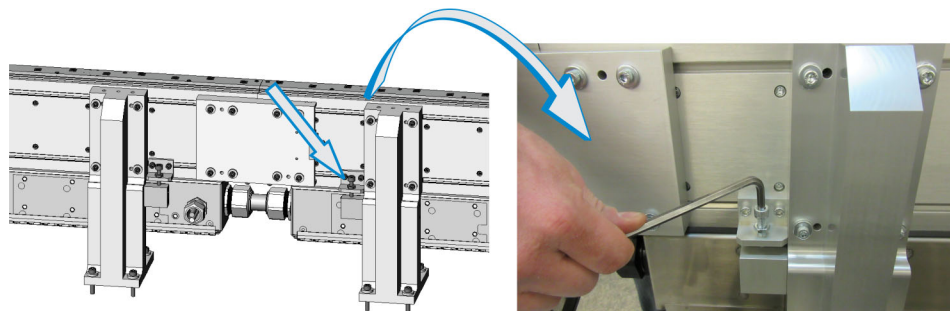

- d. Tighten the four (4) stand screws and four (4) wedge screws that were loosened in step a and b.

2. If horizontal (IN or OUT) upper v-rail adjustment is required, complete the following steps on the side that requires adjustment:

a. Loosen the four (4) screws at the bottom of the stand.

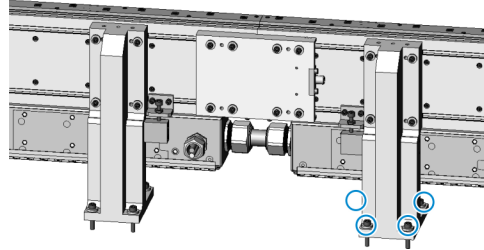

b. Loosen the four (4) wedge screws.

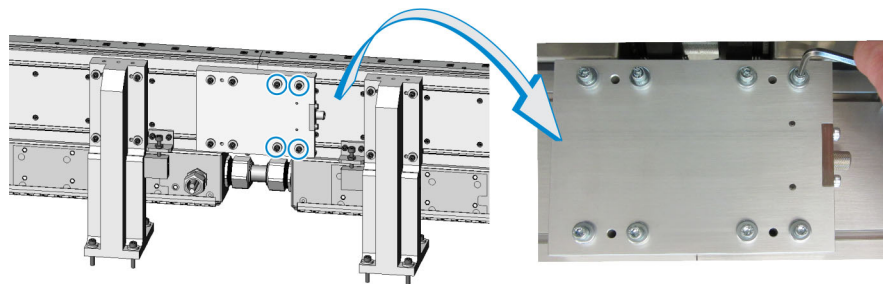

c. Turn the wedge adjustment knob, as required, to adjust the upper v-rail IN or OUT.

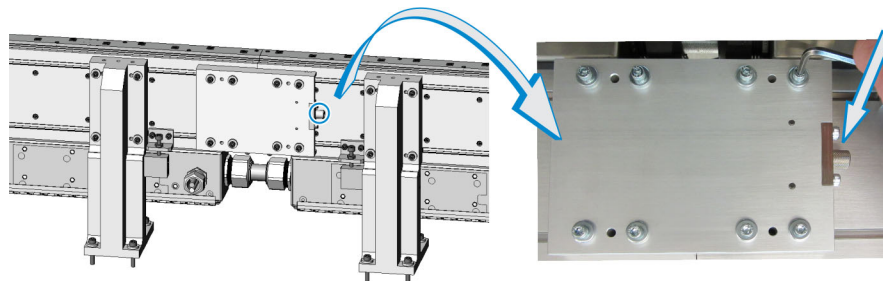

d. Tighten the four (4) stand screws and four (4) wedge screws that were loosened in step a and b.

3. Repeat steps 2 to 4 of *Fine-Adjust the Upper V-Rail* on page 103.

**Adjust the Upper V-Rail  $\pm 0.05$  mm ( $\pm 0.002$  in.) - Straight Section to 180 Deg. Section**

1. If vertical upper v-rail adjustment is required, complete the following steps on the side that requires adjustment:
  - a. Loosen the four (4) screws at the bottom of the stand.

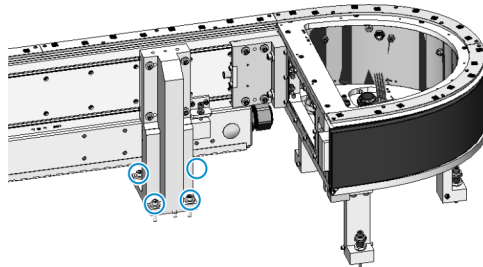

- b. Loosen the four (4) wedge screws.

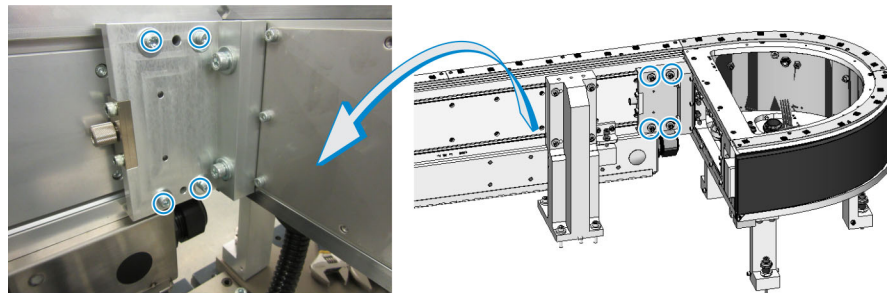

- c. Turn the height adjustment screw as required to adjust the upper v-rail height (up or down).

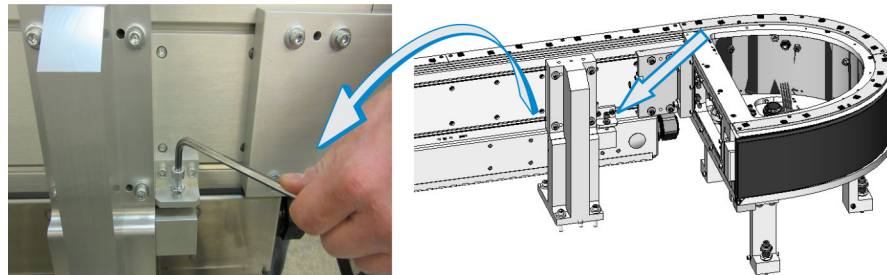

- d. Tighten the four (4) stand screws and four (4) wedge screws that were loosened in step a and b.

2. If horizontal (in or out) upper v-rail adjustment is required, complete the following steps on the side that requires adjustment:

a. Loosen the four (4) stand screws. This allows the stand to shift rather than flex against the rigid stand.

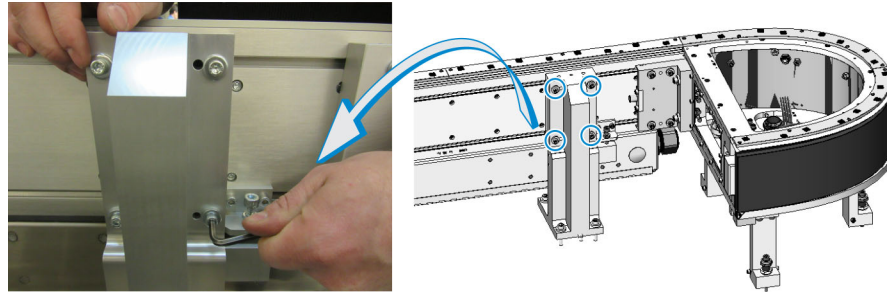

b. Loosen the four (4) wedge screws.

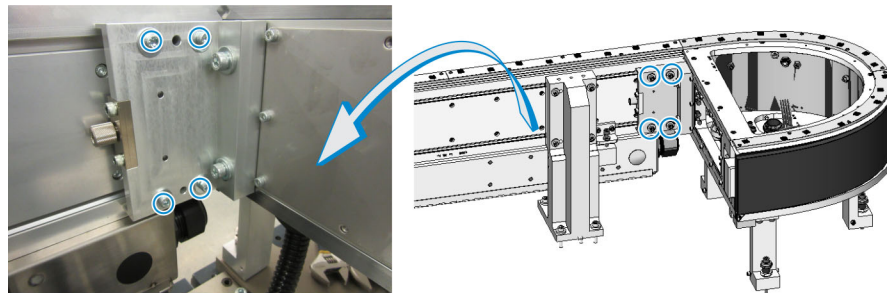

c. Turn the wedge adjustment knob, as required, to adjust the upper v-rail in or out.

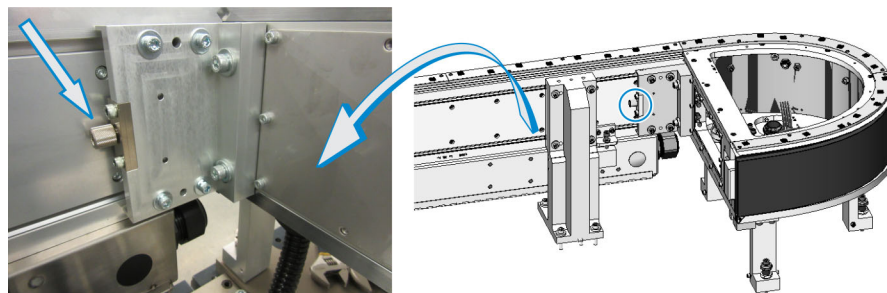

d. Tighten the four (4) stand screws and four (4) wedge screws that were loosened in step a and b.

3. Repeat steps 2 to 4 of *Fine-Adjust the Upper V-Rail* on page 103.

## Specialized Upper V-Rail Adjustment - Straight Section to Straight Section



This is a specialized procedure that is not generally required.

The most important alignment for pallets to travel smoothly is the upper v-rail alignment. The second most important alignment is the lower flat rail alignment. Minor misalignment is acceptable because the wear strip straddles it, but if it is misaligned too much, the wear strip will flex and create an audible “clicking” sound. The third most important alignment is the laminations. If these are not aligned, a magnetic “bump” can occur as pallets travel across it.

For all three alignments, the wedge adjust generally allows for alignment that is adequate enough.

1. Remove the encoder assembly.  
See [Replace an Encoder Assembly](#) on page 165.
2. Loosen the upper v-rail screws.

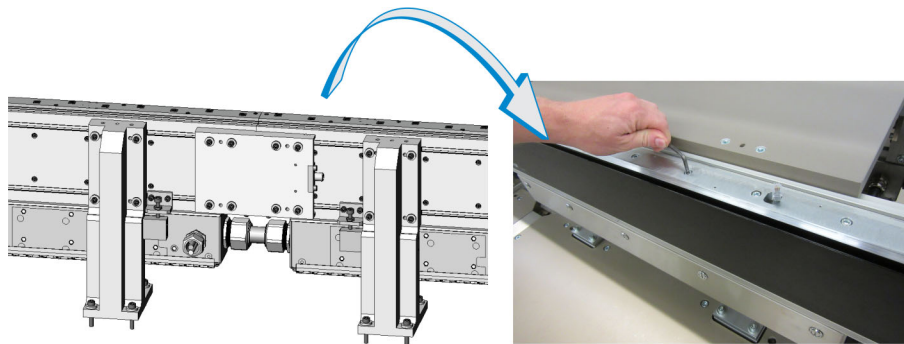

3. At the end of the upper v-rail that requires adjustment, remove the 0.25 mm (0.01 in.) shim and replace it with a smaller or larger shim as required.  
For example, a shim would be placed in the area indicated if the right side required outward adjustment.

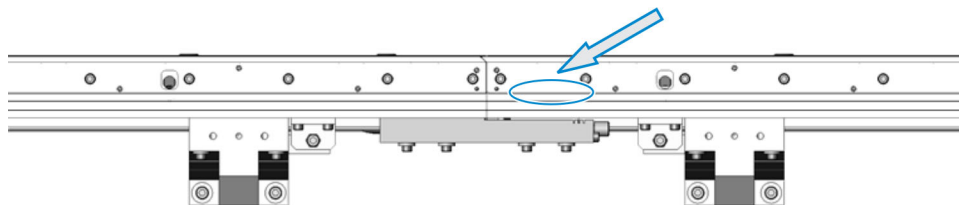

4. Re-install the encoder assembly that was removed in step 1.
5. Repeat steps 2 to 4 of [Fine-Adjust the Upper V-Rail](#) on page 103.



## Specialized Upper V-Rail Adjustment - Straight Section to 180 Deg. Section



This is a specialized procedure that is not generally required.

The most important alignment for pallets to travel smoothly is the upper v-rail alignment. The second most important alignment is the lower flat rail alignment. Minor misalignment is acceptable because the wear strip straddles it, but if it is misaligned too much, the wear strip will flex and create an audible “clicking” sound. The third most important alignment is the laminations. If these are not aligned, a magnetic “bump” can occur as pallets travel across it.

For all three alignments, the wedge adjust generally allows for alignment that is adequate enough.

1. Remove the encoder assembly.  
See [Replace an Encoder Assembly](#) on page 165.
2. Loosen the upper v-rail screws.

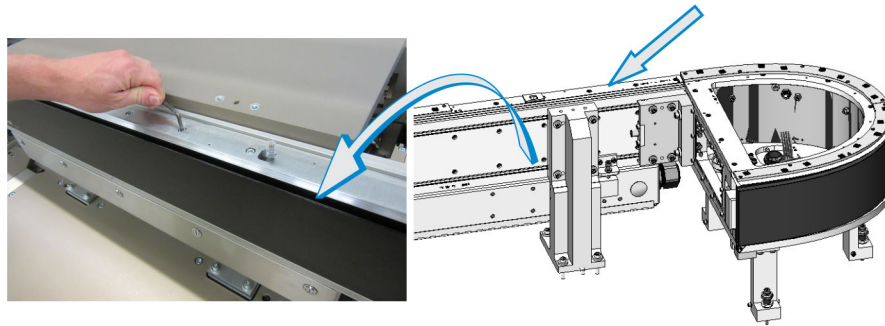

3. At the end of the upper v-rail that requires adjustment, remove the 0.25 mm (0.01 in.) shim and replace it with a smaller or larger shim as required.  
For example, a shim would be placed in the area indicated if the right side required outward adjustment.

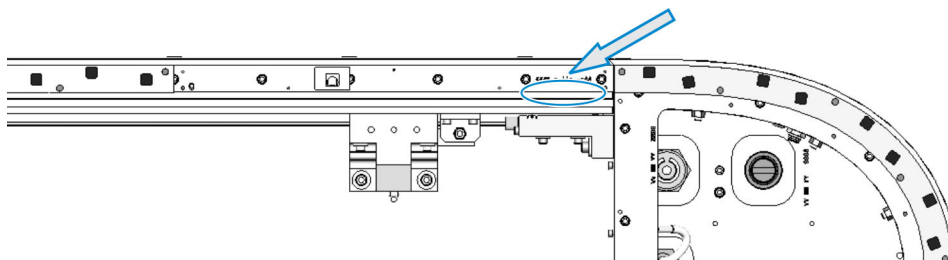

4. Re-install the encoder assembly that was removed in step 1.
5. Repeat steps 2 to 4 of [Fine-Adjust the Upper V-Rail](#) on page 103.

## Install an IR Reader Mount Assembly

**NOTICE**

During this procedure, make sure the clamp plate (see “G” in the diagram below) is positioned between the clamp bolts and the joint plate when you slide the long side of the IR reader mount assembly under the joint of the two (2) adjacent straight sections. Failure to do so will result in joint plate damage.

The IR reader mount assembly can be installed in one of the following locations:

- Custom location, if it meets the following criteria:
  - The air gap between the IR reader and IR tab is 1 mm (0.039 in.).
  - The IR reader is located in front of the SuperTrak conveyance platform section that it is plugged into.
  - There is no interference with a straight section electrical door.
- Across the joint of two (2) adjacent straight sections. This installation location prevents interference with the electrical door of the straight section.

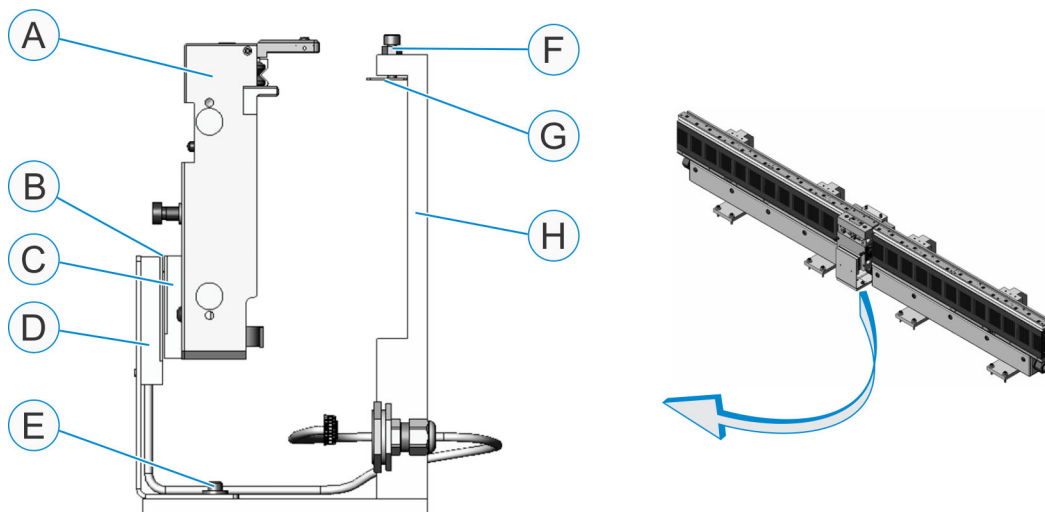

<b>A</b>	Pallet	<b>E</b>	Air gap adjustment screw (with slotted hole)
<b>B</b>	1 mm (0.39 in.) air gap	<b>F</b>	Clamp plate bolt (1 of 2)
<b>C</b>	IR tag (read-only)	<b>G</b>	Clamp plate
<b>D</b>	IR reader	<b>H</b>	IR reader mount assembly

1. Secure the IR reader to the IR reader mount assembly with two (2) screws.

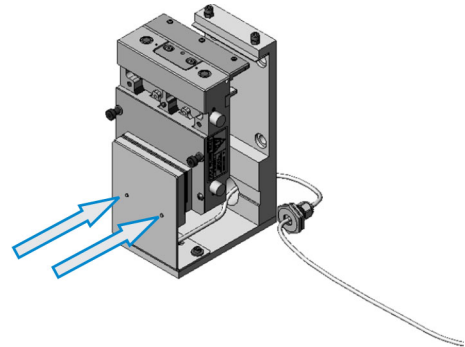

2. Route the IR reader cable through the IR reader mount assembly cable opening.

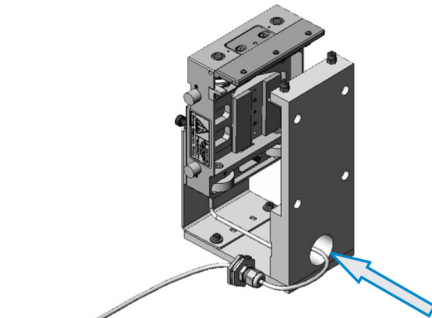

3. Slide the long side of the IR reader mount assembly under the joint of two (2) adjacent straight sections.

To prevent joint plate damage, make sure the clamp plate is positioned between the clamp bolts and the joint plate.

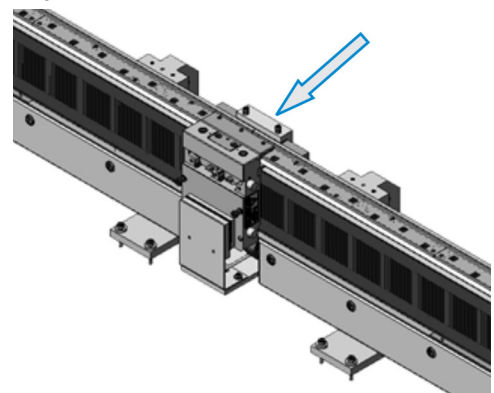

4. Tighten the two (2) clamp screws, to hold the IR reader mount in position.

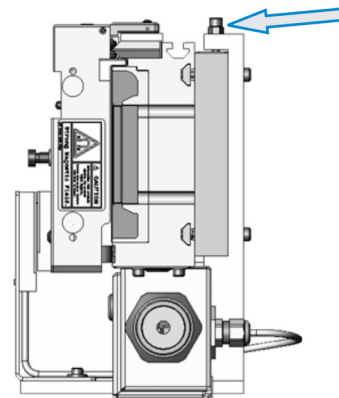

5. Route the IR reader cable into the back of the straight section electrical box, using the supplied knock-out reducer and strain relief connector.

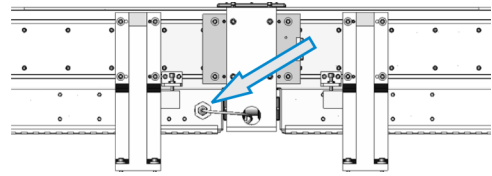

6. Plug the IR reader cable into the IR reader connection on the gateway board. It must be connected to the gateway board of the SuperTrak conveyance platform section that the IR reader is mounted on.

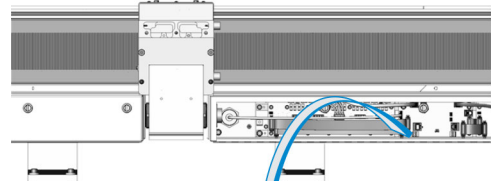

See [Gateway Board](#) on page 30.

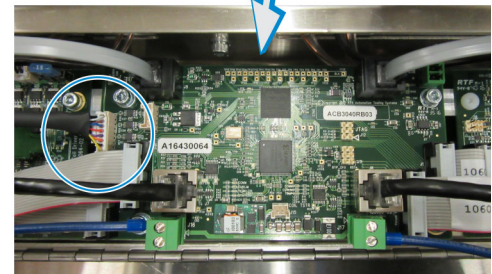

7. Slide a pallet in front of the IR reader.
8. Verify that a 1 mm (0.39 in.) gap exists between the IR tag on the pallet and the IR reader. If required, adjust the air gap adjustment screw to increase or decrease the gap.
9. Configure the IR reader.

See [Access the TrakMaster Built-in Help](#) on page 141.

# Controls and Connections

This section provides the following information about SuperTrak conveyance platform controls, and connections:

- [TrakMaster Software](#) on page 113
- [Guarding](#) on page 114
- [Energy Controls](#) on page 115
- [Connections](#) on page 116

## TrakMaster Software

---

**NOTICE**

The lifespan of some SuperTrak components may be compromised when temperature-related TrakMaster configuration parameters are adjusted from the default value.

For optimum lifespan of SuperTrak conveyance platform components, do not increase the default value of the electronics temperature configuration parameter, and use caution when increasing the coil temperature configuration parameter:

- Coil Temperature Limit (°C); default=60, hard limit=90.
- Electronics Temperature Limit (°C); default=60, hard limit=70.

---

TrakMaster is a Windows-based application that monitors, configures, and is used to troubleshoot the SuperTrak conveyance platform.

## Guarding



Unguarded devices may cause injury or death. Do not start or operate the equipment with guard doors open. Lockout and tagout all energy sources before entering the guarding. Make sure that all guard panels are in place and guard doors are closed before operating the equipment. Never bypass a safety component.

See [Hazardous Energy](#) on page 8 and [Lockout and Tagout](#) on page 11.

Guarding is a protective housing that separates users from dangers; such as, moving devices. The guarding is comprised of a framework fitted with fixed guarding panels, and removable guarding panels.

### Fixed Guard Panels

Fixed guard panels should not be removed.

### Removable Guard Panels

Removable guard panels are available for maintenance and should only be opened by a qualified technician. A tool is required to unlock and remove a panel and to lock a panel in position. These panels are not usually equipped with a safety switch; therefore, the system should not be operated with any of these panels removed.

## Energy Controls

This section describes the energy controls on the SuperTrak conveyance platform.

### SuperTrak Conveyance Platform Power Disconnect Switch



Servicing an electrical panel that is still connected to its power source may cause injury or death. Unless directed otherwise, turn the **main power disconnect** switch to the OFF position. Lock out and tag out the switch before accessing and servicing the electrical panel. Only electrical technicians should perform service on the electrical panel.

See [Hazardous Energy](#) on page 8 and [Lockout and Tagout](#) on page 11.



The SuperTrak conveyance platform control panel is designed to be integrated with a main electrical panel, which includes a **main power disconnect** switch. Use the **main power disconnect** switch to turn OFF system power, but maintain digital (UPS) power in the control panel. Only use the **SuperTrak conveyance platform power disconnect** switch when replacing a SuperTrak conveyance platform electrical component.

The SuperTrak conveyance platform power disconnect switch is located on the control panel door.

Use the **SuperTrak conveyance platform power disconnect switch** when any electronic service or maintenance work is completed.

To isolate the SuperTrak conveyance platform power, turn the **SuperTrak conveyance platform power disconnect switch** to the OFF position. The switch is lockable in the OFF position to prevent accidental or unauthorized enabling of electrical power to the system.

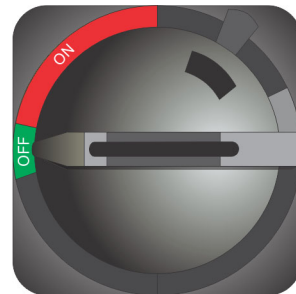

See [Hazardous Energy](#) on page 8.

### Uninterruptible Power Supply

An uninterruptible power supply (UPS) is located inside the control panel.

The UPS provides power to the controller and digital electronics. This maintains pallet position information and allows network communications to continue. The UPS does not provide motor power or cause pallet movement.

## Connections



Connection information provided in this section is based on the use of the ATS SuperTrak control panel. The control panel meets UL certification and product testing. If an alternate electrical panel is used, it must meet the guidelines defined in the *SuperTrak GEN3 Design Considerations* document.

This section describes the following SuperTrak conveyance platform connections:

- [Straight Section to Straight Section Connections](#) on page 116
- [Straight Section to 180 Deg. Section Connections](#) on page 116
- [180 Deg. Section \(500 mm\) to SuperTrak Control Panel Connection](#) on page 116
- [Ethernet Port Connection](#) on page 117
- [Main Power Connection](#) on page 118
- [Safety Circuit Connection](#) on page 119
- [PLC Connection](#) on page 120
- [Ethernet POWERLINK Connection](#) on page 121
- [Gateway Network Connections](#) on page 122

### Straight Section to Straight Section Connections

See [Replace an Electrical Interconnect](#) on page 176.

### Straight Section to 180 Deg. Section Connections

See [If required, remove the existing electrical interconnect as described above.](#) on page 177.

### 180 Deg. Section (500 mm) to SuperTrak Control Panel Connection

See [Install an Electrical Interconnect Between a Curved Section and a SuperTrak Control Panel](#) on page 179.



## Ethernet Port Connection

The Ethernet port (ETH1) connection, located inside the control panel, provides TrakMaster software communication. Any computer (for example; a laptop or HMI) can connect to ETH1 with an Ethernet cable.

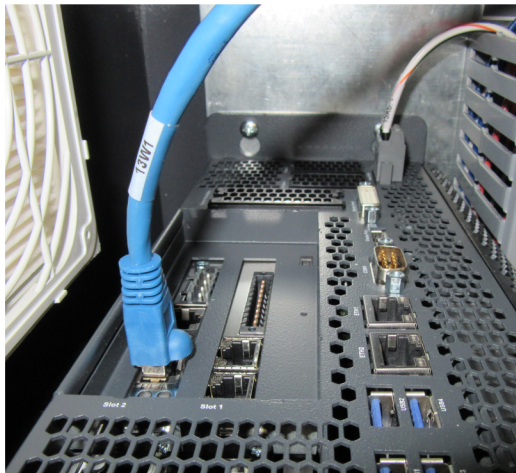
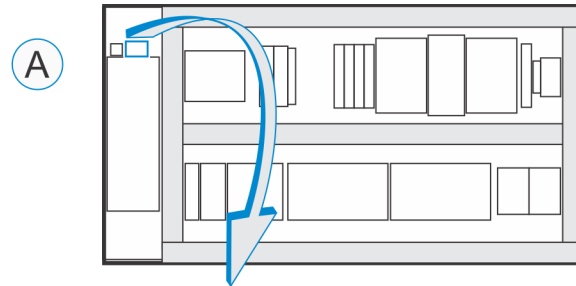

Before



After

ID	Connection Number	Connection Type	Description
A	N/A	N/A	TrakMaster Ethernet port connection location.
B	ETH1	RJ45 Ethernet	Provides TrakMaster software communication.

## Main Power Connection



For the power drop connection, phase orientation does not matter.

The main power cable (incoming) is wired through the back of the panel and into the main AC power disconnect connection, as illustrated:

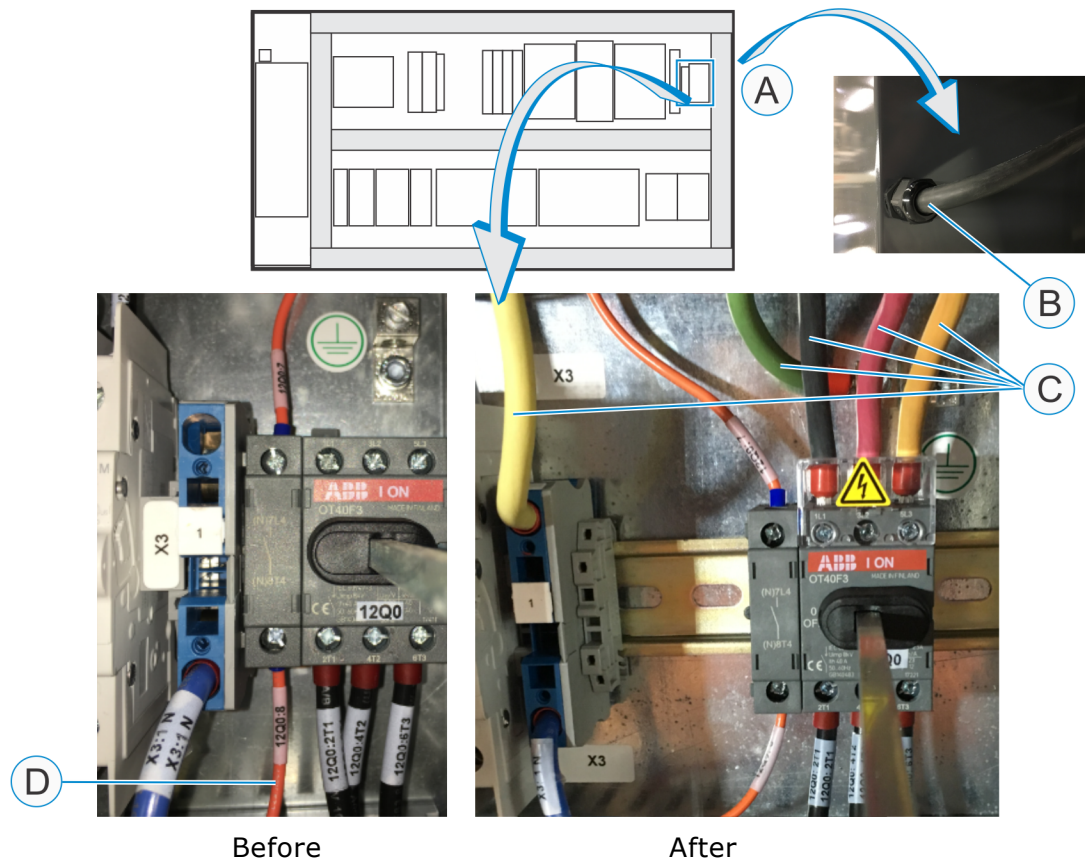

ID	Connection Number	Connection Type	Description
A	N/A	N/A	Main power connection location.
B	N/A	Main power cable	Main power supply (incoming) port at the back of the control panel.
C	N/A	Main power connection	Main power supply (incoming) connections: <ul style="list-style-type: none"> <li>• Green - PE (ground)</li> <li>• Black, Red, Orange - Phase 1, 2, or 3 (in any order)</li> <li>• White - Neutral</li> </ul>
D	12Q0:8	UPS	UPS power goes through the auxiliary contact on the main disconnect.

## Safety Circuit Connection

The SuperTrak conveyance platform is integrated with a system safety circuit in the control panel. Wire the safety circuit as illustrated:

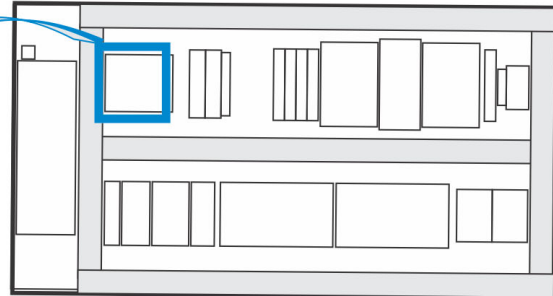
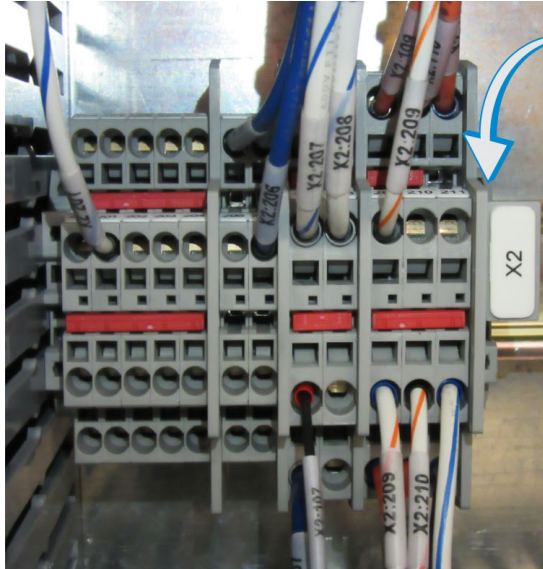

X2 Customer Connections

Simplified Safety Coil Example

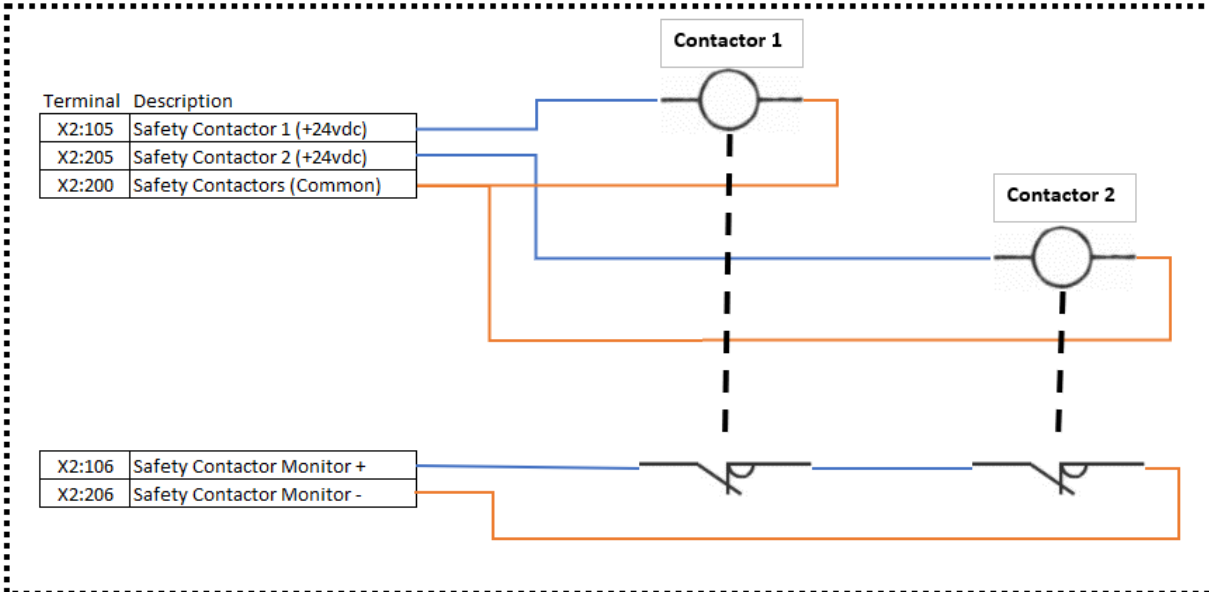

## PLC Connection

The programmable logic controller (PLC) connection is inside the control panel. An Ethernet cable is wired through the back of the panel and into the 14K1 PLC connection, as illustrated:

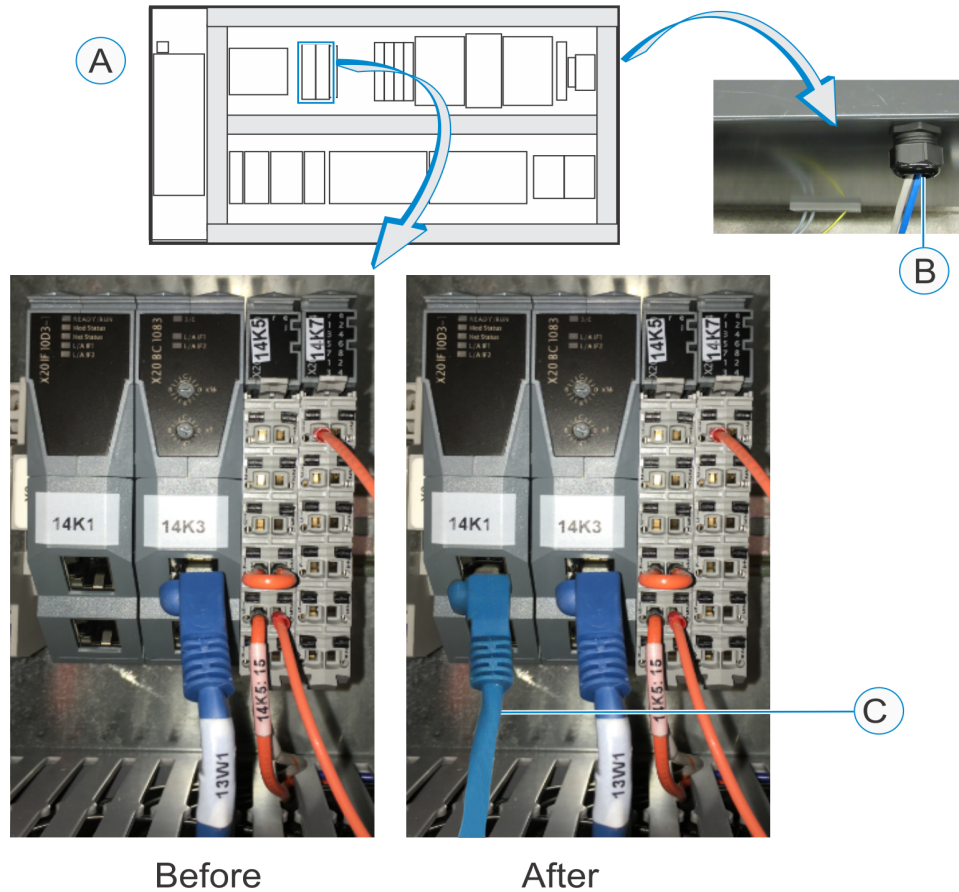

ID	Connection Number	Connection Type	Description
A	N/A	N/A	Safety circuit connection location.
B	206	Reset out	Required contactor safety monitoring connection.
C	105	24+ VDC	Incoming from the safety circuit (fail safe output). <sup>a</sup>

a. The electrical module is protocol-specific, and is supplied according to the customer's requirements.

## Ethernet POWERLINK Connection

The Ethernet POWERLINK connection exists in the control panel when it is shipped. One end of an Ethernet cable is plugged into the front port of Slot 2 on the controller, and the other end of the cable is plugged into IF1 of the bus controller, as illustrated:

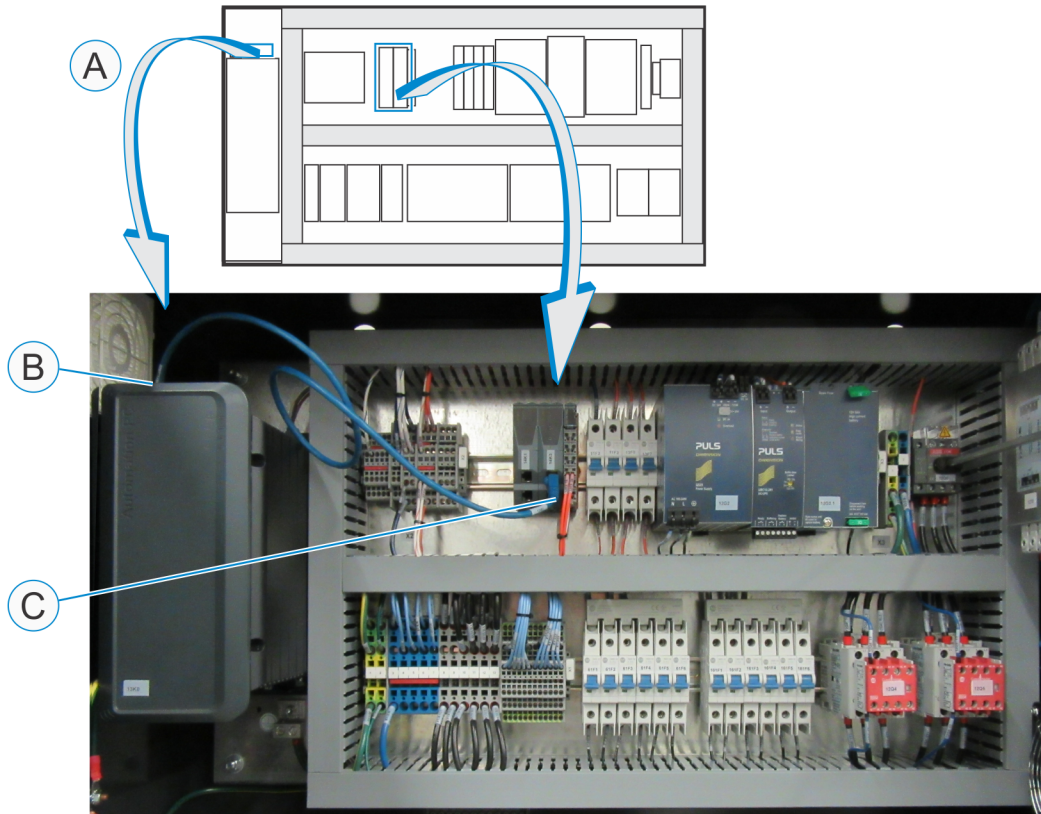

ID	Connection Number	Connection Type	Description
A	N/A	N/A	Ethernet POWERLINK connection location.
B	13K0:IF1/1	RJ45 POWERLINK connection	Connects to the controller (slot 2, front port).
C	14K3:1F1	RJ45 POWERLINK connection	Connects to the bus controller (upper port).

## Gateway Network Connections

**NOTICE** Turn OFF the 24 V gateway power, and turn OFF the controller before connecting the gateway network.



Although the gateway network connections are implemented using standard Ethernet cables, it is not an Ethernet network and should not be connected to Ethernet devices.

The gateway network connections use Ethernet cables to connect an array of gateway boards to the controller.

### Left and Right Gateway Networks

The SuperTrak conveyance platform is divided into two (2) networks: the left network, and the right network. Each network begins with a cable that is routed through the control panel electrical interconnect to the controller.

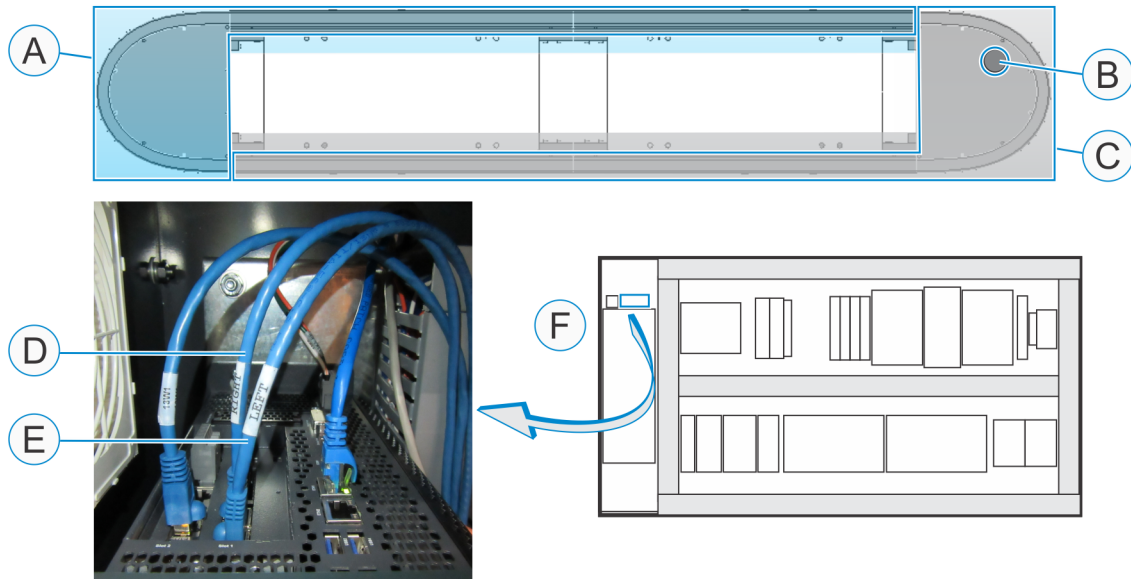

ID	Connection Type	Description
A	N/A	Right gateway network.
B	N/A	Control panel electrical interconnect. Left and right gateway network cables route to the control panel through a flexible conduit.
C	N/A	Left gateway network.
D	RJ45	Right gateway network Ethernet cable.
E	RJ45	Left gateway network Ethernet cable.
F	N/A	Left and right gateway network connection locations.

**Gateway Board Connections**

**NOTICE**

Gateway network cables should never cross one another.

As illustrated below, the left gateway connections connect to the controller upstream using the right network ports, and connect from the controller downstream using the left network ports. The right gateway connections are opposite; they connect to the controller upstream using the left network ports, and connect from the controller downstream using the right network ports.

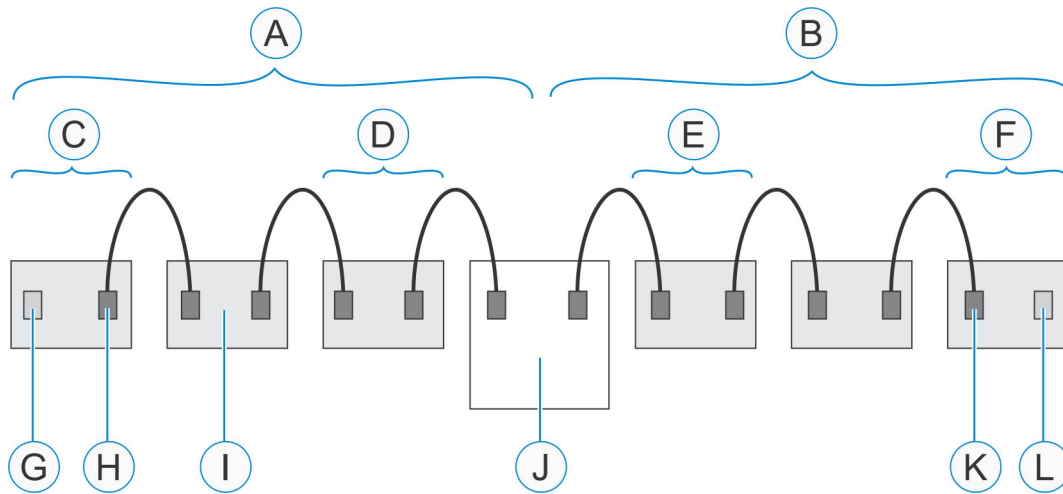

ID	Connection Type	Description
A	N/A	Left gateway network
B	N/A	Right gateway network
C	N/A	Left tail section (farthest from the controller)
D	N/A	Left head section (closest to the controller)
E	N/A	Right head section (closest to the controller)
F	N/A	Right tail section (farthest from the controller)
G	RJ45	Left network port (not connected)
H	RJ45	Right network port (connected)
I	N/A	Gateway board (1 of 6)
J	N/A	Controller
K	RJ45	Left network port (connected)
L	RJ45	Right network port (not connected)

**Straight Sections with 180 Deg (500 mm) Sections**

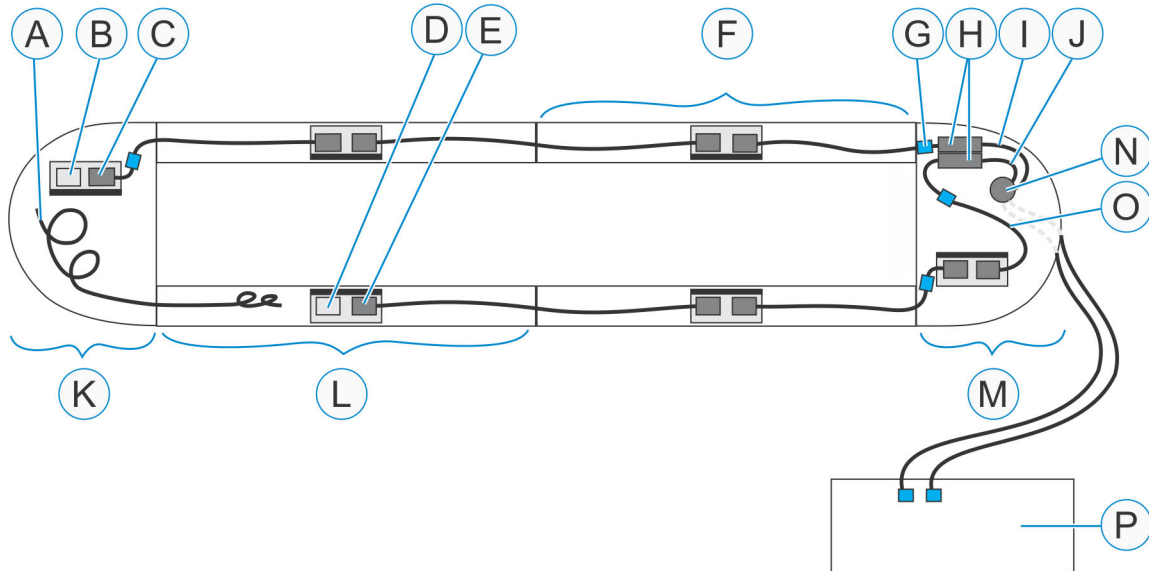

ID	Connection Type	Description
A	N/A	Ethernet cable - not connected
B	RJ45	Right network port (not connected)
C	RJ45	Left network port (connected)
D	RJ45	Left network port (not connected)
E	RJ45	Right network port (connected)
F	N/A	Right head section
G	N/A	Ferrite (1 of 6)
H	RJ45	F-F coupler
I	RJ45	Ethernet cable - right network cable from controller (connected)
J	RJ45	Ethernet cable - left network cable from controller (connected)
K	N/A	Right tail section
L	N/A	Left tail section
M	N/A	Left head section
N	N/A	Control panel electrical interconnect
O	N/A	Left network patch cable
P	N/A	Control panel



**Sample Gateway Network Connections in a 180 Deg (500 mm) Section**

The following image illustrates some of the gateway network connections. The black line through the center of the image joins two (2) images together.

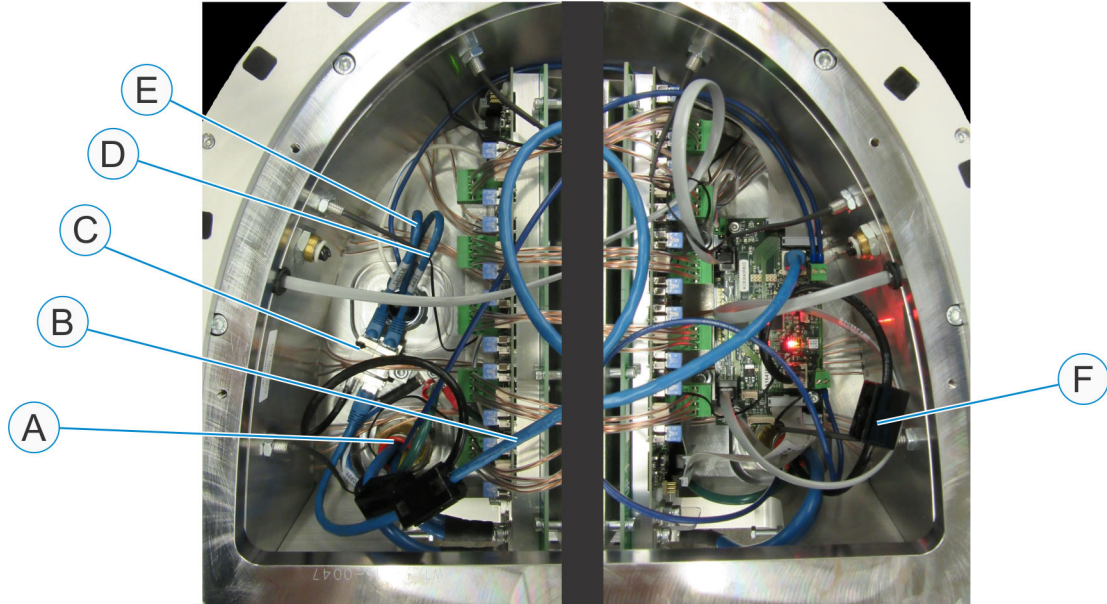

<b>A</b>	Control panel electrical interconnect	<b>D</b>	Ethernet cable - left network cable from controller (connected)
<b>B</b>	Left network patch cable	<b>E</b>	Ethernet cable - right network cable from controller (connected)
<b>C</b>	F-F coupler	<b>F</b>	Ferrite (1 of 3 shown)

**Straight Sections with 180 Deg (800 mm) Sections**

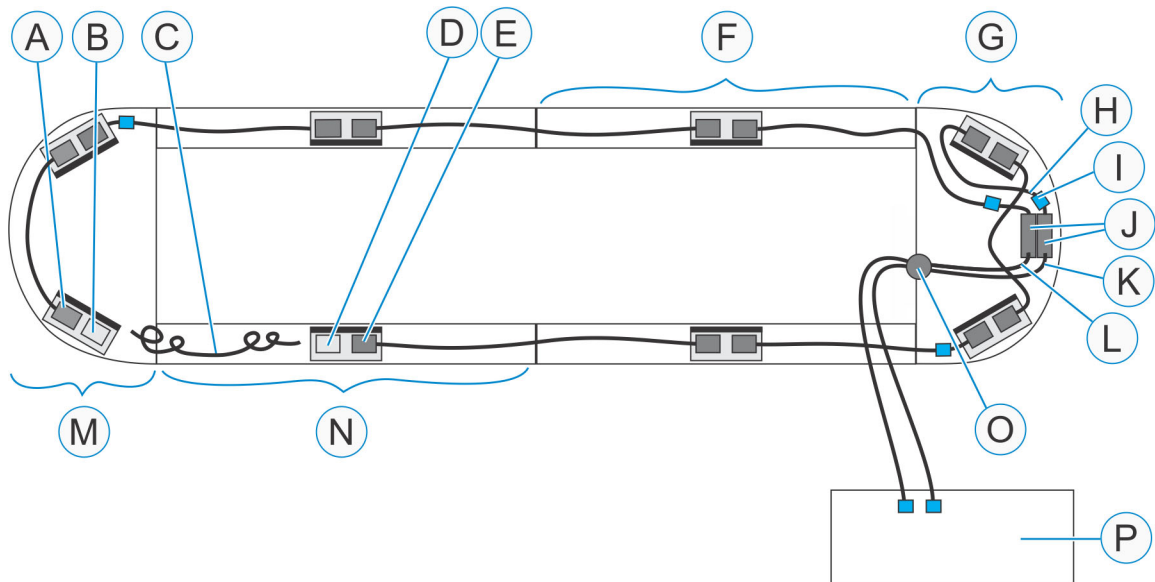

ID	Connection Type	Description
A	RJ45	Left network port (connected)
B	RJ45	Right network port (not connected)
C	N/A	Ethernet cable - not connected
D	RJ45	Left network port (not connected)
E	RJ45	Right network port (connected)
F	N/A	Right head section
G	N/A	Left head section
H	N/A	Left network patch cable
I	N/A	Ferrite (1 of 6)
J	RJ45	F-F coupler
K	RJ45	Ethernet cable - left network cable from controller (connected)
L	RJ45	Ethernet cable - right network cable from controller (connected)
M	N/A	Right tail section
N	N/A	Left tail section
O	N/A	Control panel electrical interconnect
P	N/A	Control panel

**Straight Sections with 90 Deg Sections**

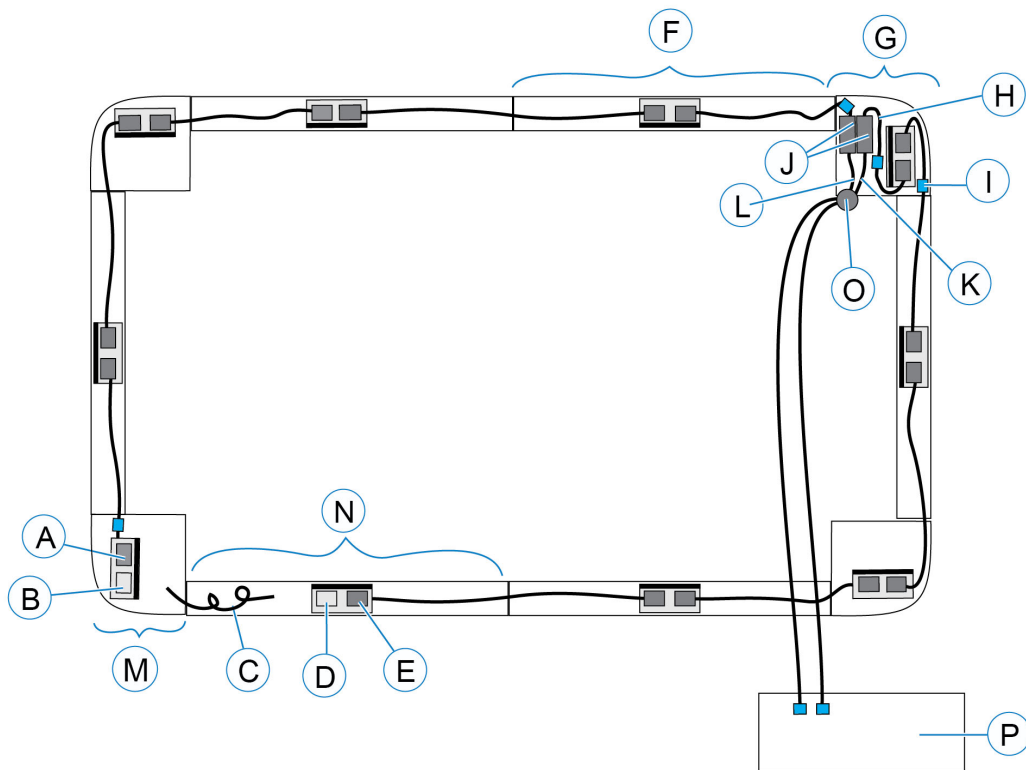
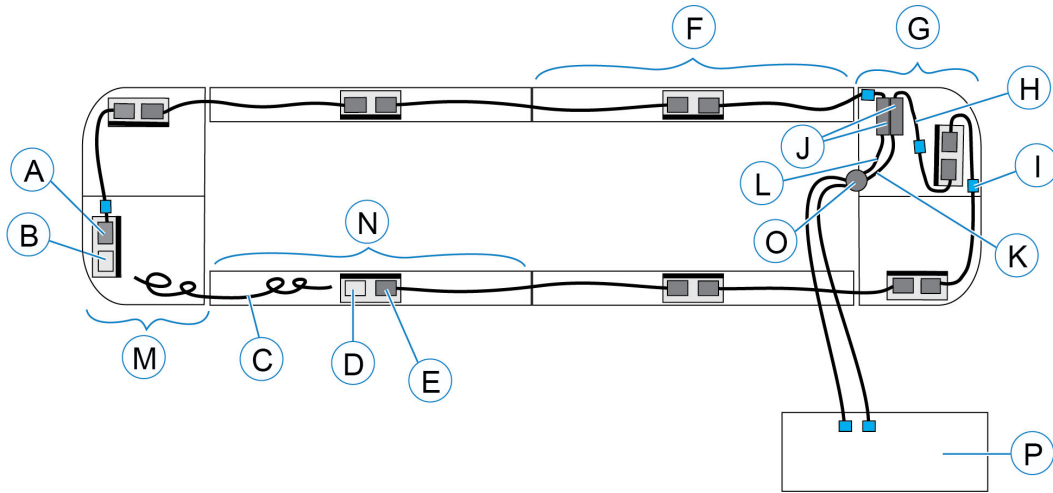

ID	Connection Type	Description
A	RJ45	Left network port (connected)
B	RJ45	Right network port (not connected)

<b>ID</b>	<b>Connection Type</b>	<b>Description</b>
<b>C</b>	N/A	Ethernet cable - not connected
<b>D</b>	RJ45	Left network port (not connected)
<b>E</b>	RJ45	Right network port (connected)
<b>F</b>	N/A	Right head section
<b>G</b>	N/A	Left head section
<b>H</b>	N/A	Left network patch cable
<b>I</b>	N/A	Ferrite (1 of 6)
<b>J</b>	RJ45	F-F coupler
<b>K</b>	RJ45	Ethernet cable - left network cable from controller (connected)
<b>L</b>	RJ45	Ethernet cable - right network cable from controller (connected)
<b>M</b>	N/A	Right tail section
<b>N</b>	N/A	Left tail section
<b>O</b>	N/A	Control panel electrical interconnect
<b>P</b>	N/A	Control panel

# Operating Procedures

This section provides the following SuperTrak conveyance platform operating procedures:

- *Pre-Start Inspection* on page 130
- *Pre-Power ON Checks* on page 132
- *SuperTrak Conveyance Platform Power ON Behavior* on page 137
- *SuperTrak Conveyance Platform Power OFF Behavior* on page 139
- *TrakMaster Procedures* on page 140
- *Monitor the SuperTrak Conveyance Platform* on page 142

# Pre-Start Inspection

**NOTICE**

Before the SuperTrak conveyance platform power is turned ON for the first time, complete the pre-power ON checks.

See [Pre-Power ON Checks](#) on page 132.

In addition, complete one (1) or more of the following to make sure the upper v-rail is adequately lubricated:

- Make sure there is a pallet for every 2 m of track.
- Add an additional 20 drops of lubricant to the pallet lubrication felt.
- Manually wipe lubricant onto the upper v-rail.

Remove excess oil from the SuperTrak that may have dripped from the upper v-rail.



During startup, the SuperTrak conveyance platform uses an identification process to locate unrecognized pallets. There could be uncontrolled pallet movement during this process. When all pallets are located, the SuperTrak conveyance platform switches to normal pallet control.

For systems where minor pallet collisions are acceptable, no action is required. Be aware that straight sections have minimal or no movement during startup, whereas curved sections may have significant movement.

For systems where pallet collisions are not acceptable, use the PLC code (or TrakMaster) before startup to determine which sections contain unrecognized pallets, and then manually move those pallets so the software can identify the pallet position.

Task	Complete
1. Verify that all users have been properly trained and instructed in safety procedures and SuperTrak conveyance platform operation.	
2. Verify that the top and bottom rails are clean and that the pallets have had the proper preventive maintenance.	
3. Inspect around the SuperTrak conveyance platform, to make sure there are no abnormal obstructions along the path that the pallets travel.	
4. Verify that all energy sources have locks and tags removed.	
5. Verify that no one is working inside the guarding.	
6. Verify that all guarding is correctly installed and operational.	
7. Complete the pre-power ON check to confirm that shorts do not exist in the system. See <a href="#">Pre-Power ON Checks</a> on page 132.	
8. Confirm that the sections are correctly aligned. Section joints and heights should not exceed $\pm 0.07$ mm (0.003 in.). See <a href="#">Align the SuperTrak Conveyance Platform Section Joints</a> on page 98, and <a href="#">Align the SuperTrak Conveyance Platform Section Heights</a> on page 99.	

	<b>Task</b>	<b>Complete</b>
9.	Disconnect the black section-to-section Ethernet cable at the end of the right network going into the left network to avoid any errors during start-ups. See <a href="#">Gateway Network Connections</a> on page 122.	
10.	Confirm that the ETH1 port is used for TrakMaster to communicate with SuperTrak. See <a href="#">Ethernet Port Connection</a> on page 117.	
11.	Confirm that the right and left network cables are correctly connected. See <a href="#">Left and Right Gateway Networks</a> on page 122.	
12.	Open TrakMaster. The default IP address for the SuperTrak is 192.168.13.2. The computer must be connected to the ETH1 port on the controller computer. <ul style="list-style-type: none"> <li>• Confirm the communication.</li> <li>• Confirm that faults and warnings do not exist.</li> <li>• Confirm that the latest controller software is installed (<b>Advanced &gt; Firmware</b>)</li> </ul>	
13.	Calibrate the encoders. See the TrakMaster built-in help for the calibration procedure.	
14.	Verify stable motion of a single SuperTrak pallet: <ol style="list-style-type: none"> <li>1. Install a <u>single</u> SuperTrak pallet on the SuperTrak conveyance platform.</li> <li>2. Confirm that the motor power supply is ON.                On TrakMaster, check the <b>Motor Power</b> column on the <b>System Status/Control</b> screen.</li> <li>3. Move the pallet around the system at a high speed (2500 mm/sec).</li> <li>4. Verify that no abnormal sounds or pallet instability is detected.</li> </ol>	
15.	Verify stable motion of all SuperTrak pallets: <ol style="list-style-type: none"> <li>1. Turn the motor power OFF.                On TrakMaster, check the <b>Motor Power</b> column on the <b>System Status/Control</b> screen.</li> <li>2. Install all required SuperTrak pallets on the SuperTrak conveyance platform.</li> <li>3. Verify that the number of pallets on TrakMaster match the physical number of pallets on the SuperTrak conveyance platform.</li> <li>4. Turn the motor power ON.</li> <li>5. Move the pallets around the system at high speed (2500 mm/sec).</li> <li>6. Verify that no abnormal sounds or pallet instability is detected.</li> </ol>	

## Pre-Power ON Checks

### NOTICE

- Before the SuperTrak conveyance platform power is turned ON for the first time, complete the pre-power ON checks.
- If any straight or curved section is added or removed, complete the pre-power ON checks.
- If a circuit board or power cable is replaced, complete the pre-power ON checks.

Complete the pre-power ON check procedure before you turn the SuperTrak conveyance platform power ON:

- After completing a new SuperTrak conveyance platform installation.
- After a straight section or curved section is added or removed.
- After a circuit board is replaced.
- After a power cable is replaced.

### Prerequisites

- Digital multimeter
- Set of metric hex keys

### Procedure

1. Open the electrical door of a straight section.
2. Set a digital multimeter to measure resistance.
3. Measure the resistance between the following:
  - Motor power connection and the common connection.  
See *Measure the Resistance Between the Motor Power Connection and the Common Connection* on page 133.
  - Ground (frame) and the common connection.  
See *Measure the Resistance Between the Ground (Frame) and the Common Connection* on page 134.
  - Common connection and the 24V digital power connection.  
See *Measure the Resistance Between the Common Connection and the 24V Digital Power Connection* on page 135.
  - Motor power connection and the 24V digital power connection.  
See *Measure the Resistance Between the Motor Power Connection and the 24V Digital Power Connection* on page 136.
4. If all step 3 resistance tests pass, it is safe to turn the SuperTrak conveyance platform power ON.



## Measure the Resistance Between the Motor Power Connection and the Common Connection

1. Test the resistance as shown below:

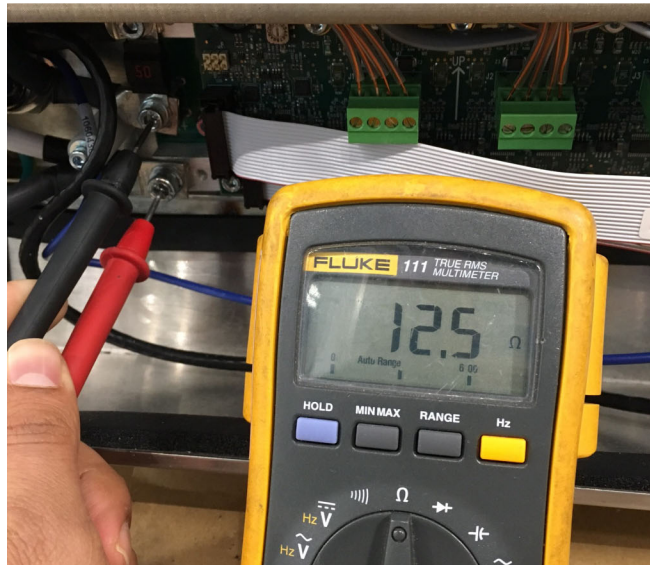
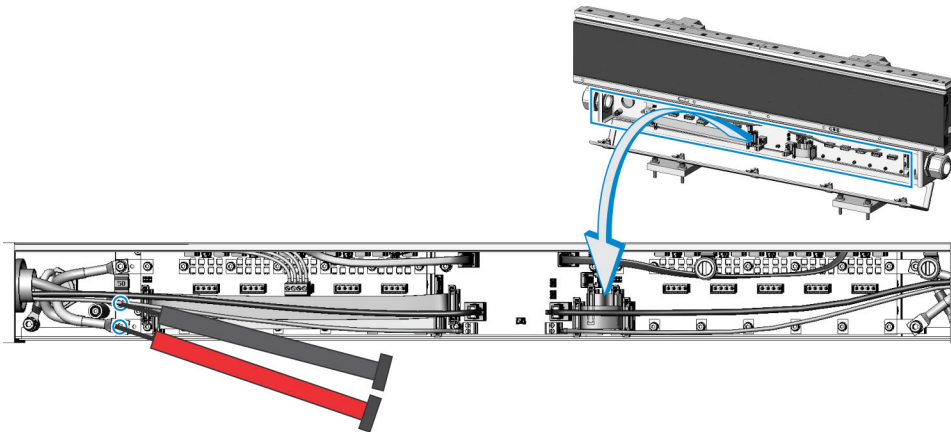

2. Look at the value displayed on the multimeter screen and determine if the resistance is acceptable:

- Pass - The value is initially  $<10\Omega$  and then slowly rises to  $>10\Omega$ . This occurs because the capacitors are charging.
- Fail - The value quickly settles at  $<5\Omega$ . This indicates that a short exists.

See *A short exists between the motor power connection and the common connection or ground (frame)*, on page 252.

## Measure the Resistance Between the Ground (Frame) and the Common Connection

1. Test the resistance as shown below:

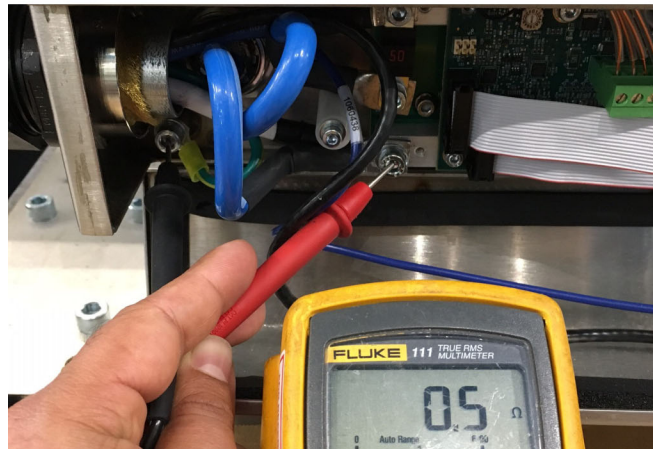
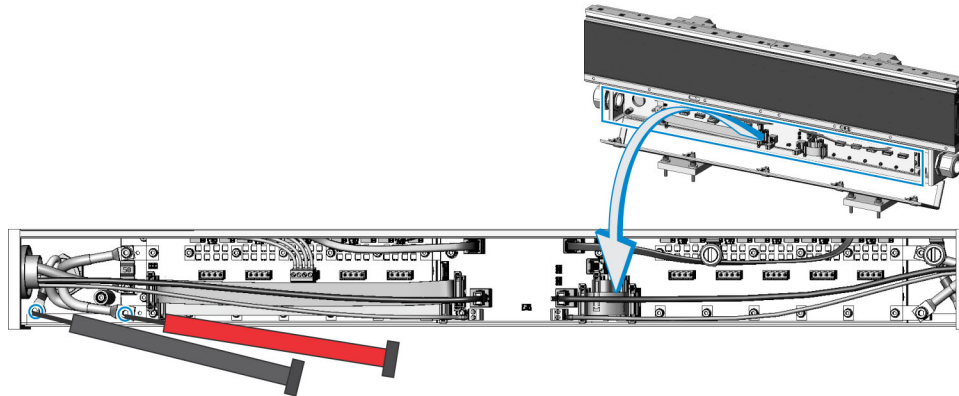

2. Look at the value displayed on the multimeter screen and determine if the resistance is acceptable:
  - Pass - The value is  $<1\Omega$ .
  - Fail - The value is  $>1\Omega$ .
3. Verify that the bonding jumper is correctly installed in the 180 deg. section that contains the control panel electrical interconnect.

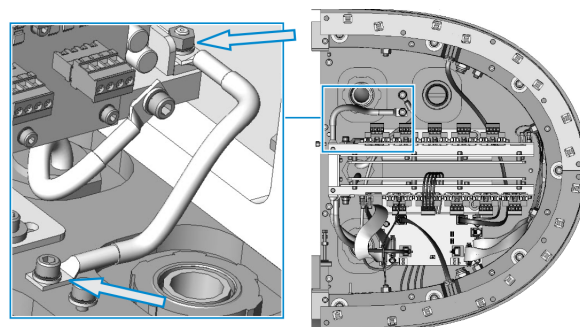

## Measure the Resistance Between the Common Connection and the 24V Digital Power Connection

1. Test the resistance as shown below:

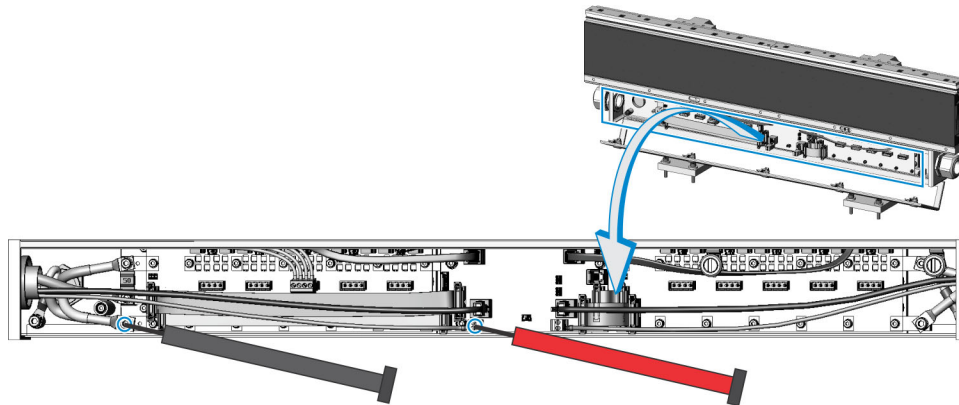

2. Look at the value displayed on the multimeter screen and determine if the resistance is acceptable:

- Pass - The value is initially  $<500\Omega$  and then quickly rise to  $>1000\Omega$ . This occurs because the capacitors are charging.
- Fail - The value quickly settles at  $<5\Omega$ . This indicates that a short exists.

See *A short exists between the 24V digital power connection and the common connection or ground (frame)*. on page 253.

## Measure the Resistance Between the Motor Power Connection and the 24V Digital Power Connection

1. Test the resistance as shown below:

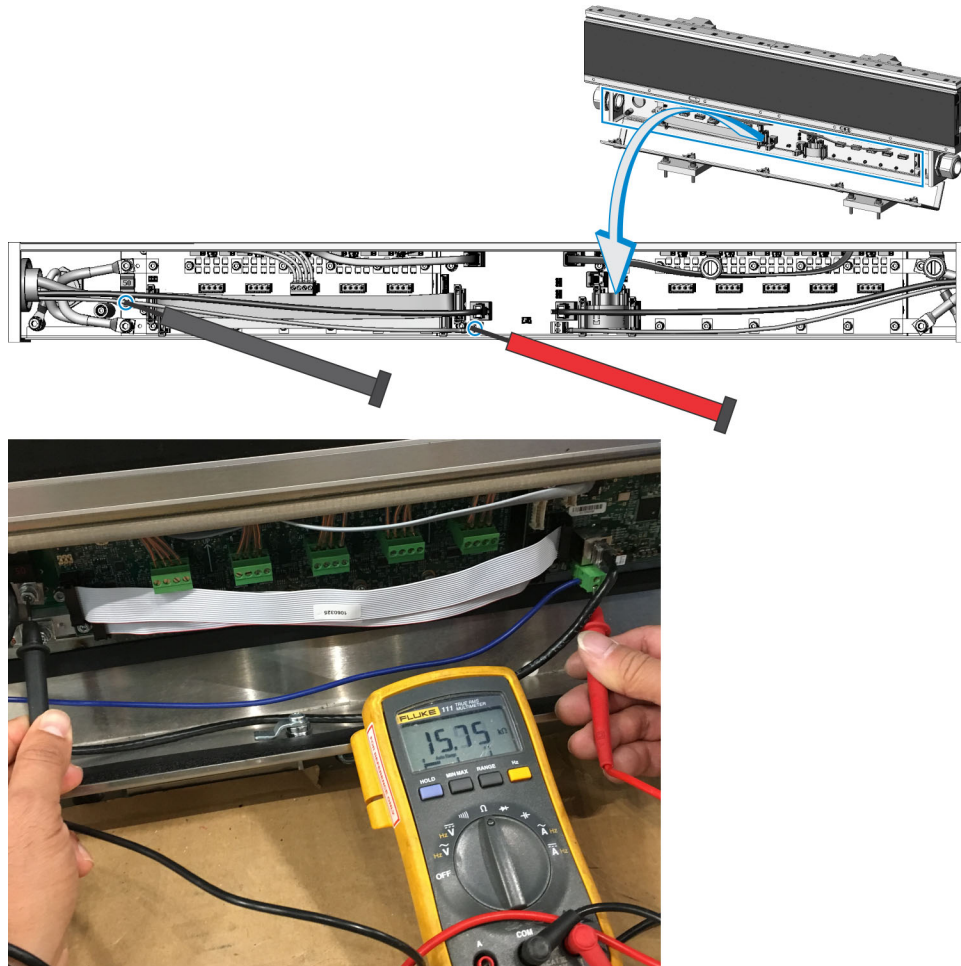

2. Look at the value displayed on the multimeter screen and determine if the resistance is acceptable:

- Pass - The value is  $>10\Omega$ .
- Fail - The value is  $<10\Omega$ . This indicates that a short exists.

See *A short exists between the motor power connection and the 24V digital power connection.* on page 254.

## SuperTrak Behavior



The SuperTrak conveyance platform is typically integrated with a larger automation system. This section describes the SuperTrak conveyance platform power ON procedure and does not include any steps for the larger system.

Each section has two (2) power connections:

- Motor power (28VDC for high power sections, 15VDC for low power sections,)
- Digital power (24V)

Motor power turns OFF with the safety circuit, but digital power remains ON. The digital power maintains feedback from the encoders, so that the SuperTrak conveyance platform continues to monitor the pallet positions.

The SuperTrak conveyance platform digital power turns ON when the **main power disconnect switch** is placed in the ON position (if the **SuperTrak conveyance platform power disconnect switch** is in the ON position). This provides power to the SuperTrak conveyance platform controller, encoders, and other digital electronics in the motors. The SuperTrak Conveyance Platform digital power can be ON prior to the main disconnect turning ON if the UPS has battery power remaining.

## SuperTrak Conveyance Platform Power ON Behavior

When the system is in a safe state and cell power is ON, the system safety circuit turns the fail safe output ON to the SuperTrak conveyance platform control panel, which turns the SuperTrak conveyance platform motor power supplies ON. This must only occur when the guard doors are closed and the system is in a safe state to start operation. To avoid rapid switching of the SuperTrak conveyance platform power supplies, the system safety circuit must be configured with a minimum 2 second delay after the fail safe output turns OFF before it turns back ON.

When the PLC is ready to allow pallet motion, the PLC enables the SuperTrak conveyance platform by turning ON defined bits on the PLC network. Pallet movement does not occur until the PLC enables pallet motion. The PLC can enable pallet motion at the system level or for individual sections. The PLC must verify that all robots and tooling are clear before it enables pallet motion.

When the PLC enables pallet movement, the SuperTrak conveyance platform initializes the pallets, returns them to their proper starting location, and then moves pallets as required.

The system startup procedure varies, depending on whether the UPS has timed out or not and digital power was lost:

- If digital power is not lost, all pallet locations and data are maintained. The system continues to work from where it left off.
- If digital (UPS) power is lost and a cold start occurs, the pallets travel to the default target locations and the PLC decides what to do next for startup. Multiple options are available to manage system startup after a cold start, for example:
  - The PLC can cycle all pallets around the SuperTrak conveyance platform, determine the pallet ID, return the pallets to the stations they left off, and continue running.
  - If the PLC knows that the line was purged, the pallets can all go to the first processing station by default and the system can start running.
  - The PLC can send all pallets to a reject station where any parts partially processed are removed and the system starts over after a cold start.
  - The SuperTrak conveyance platform digital electronics can be wired to the equivalent of a panel lighting circuit that does not lose power when the main disconnect is switched OFF. In this case, the SuperTrak conveyance platform pallet positions and data are always maintained unless the entire plant loses power and the battery backed UPS times out.

## SuperTrak Conveyance Platform Power OFF Behavior

To stop the system, the PLC disables the SuperTrak conveyance platform over the network at the appropriate time. This is typically triggered by a system **cycle stop** or **cycle end** button on the PLC-controlled operator interface. For example:

- The PLC can complete all current operations, move tooling clear, and then disable the SuperTrak conveyance platform.
- The PLC can completely purge the line of parts, and then disable the SuperTrak conveyance platform. When the system stops, the user turns the **main power disconnect switch** to the OFF position.

When the PLC detects that the safety circuit is open (for example; a guard door is open, or an emergency stop button is activated), it immediately drops the enable signal to the SuperTrak conveyance platform. This causes pallets to decelerate to a controlled stop. At the same time, the system safety circuit maintains the fail safe output to the SuperTrak conveyance platform for a time delay OFF of 100-300 milliseconds. The amount of time is configured based on pallet speed and payload, to make sure that there is adequate time for the pallets to stop. A 300 millisecond delay is adequate for a pallet with high payload traveling at full speed.

The disable delay time is set in both the system safety circuit and in the TrakMaster software (see **Section Parameters > Section Disable Delay Time**). When the disable delay time is correctly configured, pallets come to a controlled stop and avoid bumping on an abrupt cell power OFF. If a disable delay time is not configured (**Section Disable Delay Time** is set to zero [0]), the SuperTrak conveyance platform shorts the coils to help decelerate the pallets on cell power OFF, which minimizes how far the pallets coast.

# TrakMaster Procedures



TrakMaster is not required to operate the SuperTrak conveyance platform; however, it is useful for troubleshooting and configuring the SuperTrak conveyance platform.

TrakMaster is a Windows-based application that monitors, configures, and is used to troubleshoot the SuperTrak conveyance platform.

## Download TrakMaster

1. Email [supertrak\\_support@atsautomation.com](mailto:supertrak_support@atsautomation.com) to obtain a login account.
2. Navigate to <http://atsautomation.leapfile.com/>.
3. Click **File Portal**.

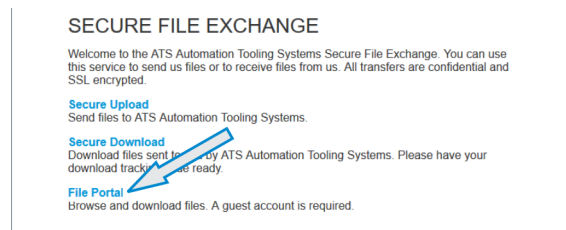

4. Enter your **Login ID** and **Password**, and then click **Login**.
5. Click **SuperTrak G3**.
6. Complete one (1) of the following:
  - Select the checkbox(es) of the required software version, and then click **Download Selected**.

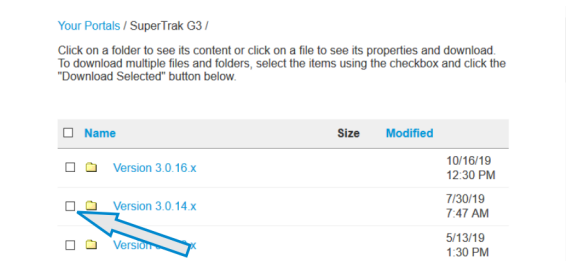

- Click a folder to view the folder contents, select the checkbox(es) of the required files, and then click **Download**.

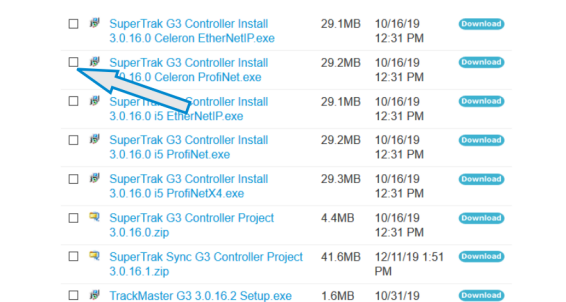



## Login to TrakMaster

1. Open TrakMaster.
2. Click **File > Login**.
3. Enter your **User Name** and **Password**.

User accounts and the associated permissions are configurable. The software includes the following initial accounts: **Administrator**, **Programmer**, **Maintenance**, and **Operator**. All passwords are initially **password**.

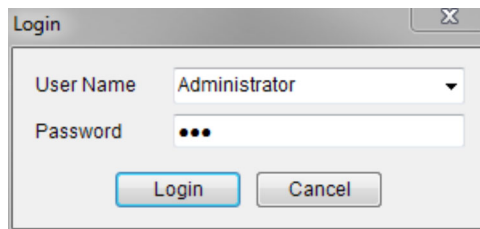

4. Click **Login**.

If login is successful, TrakMaster displays the SuperTrak Connections dialog; otherwise, TrakMaster displays an error message and the Login dialog.

See [Access the TrakMaster Built-in Help](#) on page 141.

## Access the TrakMaster Built-in Help



See the **Quick Start** section for initial SuperTrak conveyance platform connection and configuration instructions.

1. Open TrakMaster.
2. Click **Help > Contents**.

## Monitor the SuperTrak Conveyance Platform

It is important to be aware of the state of SuperTrak conveyance platform during operation. When you are aware of how the SuperTrak conveyance platform correctly works, it is easier to notice when a change occurs. Some things to notice include:

- Watch all devices for smooth operation. If a device does not seem to be operating correctly, stop the SuperTrak conveyance platform and notify a service technician.
- Be aware of the speed at which the components function. If they appear to move slower than usual or are progressively getting slower, maintenance may be required.
- Watch for debris accumulation on the upper v-rail. This is an indication that the pallets require immediate lubrication.
- Watch for debris accumulation on the lower rails. Wipe down the lower rails with a clean cloth dampened with isopropyl alcohol or equivalent.
- Watch for repeated faults and listen for pallet noise. Inspect and repair the pallet as required.
- Listen for knocking sounds as the pallets travel over the upper v-rail joins. Knocking sounds are an indication that the upper v-rail requires adjustment.

# Technician Procedures

This section provides the following technician procedures:

- *Electrical Procedures* on page 144
  - *Install a Power Supply* on page 145
  - *Install a Power Supply* on page 145
  - *Replace an Electrical Interconnect* on page 176
  - *Replace a Coil Driver Board* on page 150
  - *Replace a Gateway Board* on page 157
  - *Replace an Encoder Assembly* on page 165
  - *Replace a Motor Thermistor* on page 168
  - *Replace the Main Motor Fuse* on page 173
  - *Replace a Coil Fuse* on page 174
  - *Replace an Electrical Interconnect* on page 176
- *Mechanical Procedures* on page 191
  - *Install a Pallet* on page 191
  - *Inspect a Pallet* on page 195
  - *Replace a Pallet Bumper* on page 198
  - *Replace the Pallet Flat Wheels* on page 199
  - *Replace the Pallet V-Wheels* on page 201
  - *Replace a Pallet Magnet Assembly* on page 205
  - *Replace a Pallet Anti-Static Brush* on page 206
  - *Adjust a Pallet Shim* on page 207
  - *Replace a Pallet Lubrication Felt* on page 210
  - *Replace a Pallet Spring* on page 211
  - *Replace a Pallet Encoder Strip Assembly* on page 212
  - *Install a Station Setup Fixture* on page 214
  - *Align a Pallet Encoder Strip Assembly* on page 215
  - *Replace an Upper V-Rail* on page 230
  - *Replace a Flat Wear Strip* on page 238
  - *Replace a Motor Cover Label* on page 243
  - *Replace a Straight Section* on page 244

## Electrical Procedures

** DANGER**

Completing any maintenance procedures with the SuperTrak conveyance platform electrically powered may result in serious injury or death. Lock out and tag out all electrical energy sources before part service or replacement.

See [Hazardous Energy](#) on page 8, and [Lockout and Tagout](#) on page 11.

**NOTICE**

To prevent damage to electrical components from electrostatic discharge (ESD), always use an ESD wrist strap when working with electrical components. An ESD wrist strap prevents the buildup of static electricity.

This section provides SuperTrak conveyance platform electrical procedures.

## Install a Power Supply

**NOTICE**

- Make sure the power supply is wired correctly during installation. Incorrect wiring causes component damage.
- The length of the 28VDC power cable (between the power supply and track section) must be the same for all power supplies on the same system to obtain the correct voltage and power balancing.
- It is recommend to distribute the power supplies as evenly as possible around the SuperTrak conveyance platform.

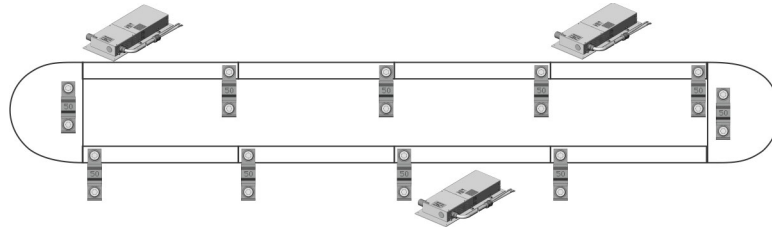

If possible, install the power supplies on the sections with the highest performance demands.

- Ensure that each power supply has at least 50 mm of space around all sides, with venting holes and fan(s), to allow for proper air flow.



For a wiring overview, see the wiring pin-out overview label located on the electrical door of each straight section and curved section during this procedure.

The number of installed power supplies varies, depending on the demands of the specific SuperTrak conveyance platform.

This diagram describes the location of the components that are required to install the power supply.

<b>A</b>	Power supply OK signal
<b>B</b>	28 VDC power output location
<b>C</b>	Mounting plate
<b>D</b>	Mounting bracket (1 of 4)
<b>E</b>	Mounting plate screw (1 of 4)
<b>F</b>	AC power input plug
<b>G</b>	Tested label

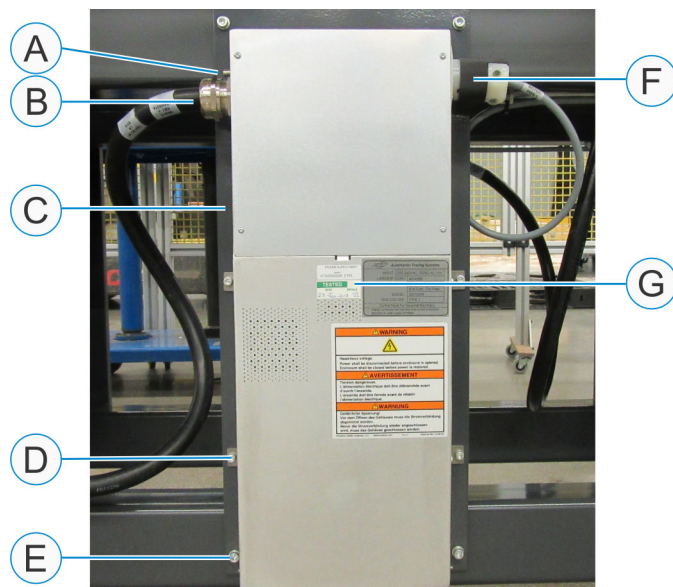

See [Power Supply](#) on page 42.

## Replace or Install a New Power Supply

1. Turn the **SuperTrak conveyance platform power disconnect switch** to the OFF position.
2. Lock out and tag hazardous energy.  
See *Lockout and Tagout Locations* on page 12.

3. If you are installing a new power supply, complete the following steps:

- a. Determine the power supply installation location.
- b. Drill and tap four (4) holes into the frame.  
The holes must align with the mounting plate holes.
- c. Secure the mounting plate to the frame with four (4) screws.
- d. As required, remove the black plug in the section before connecting.

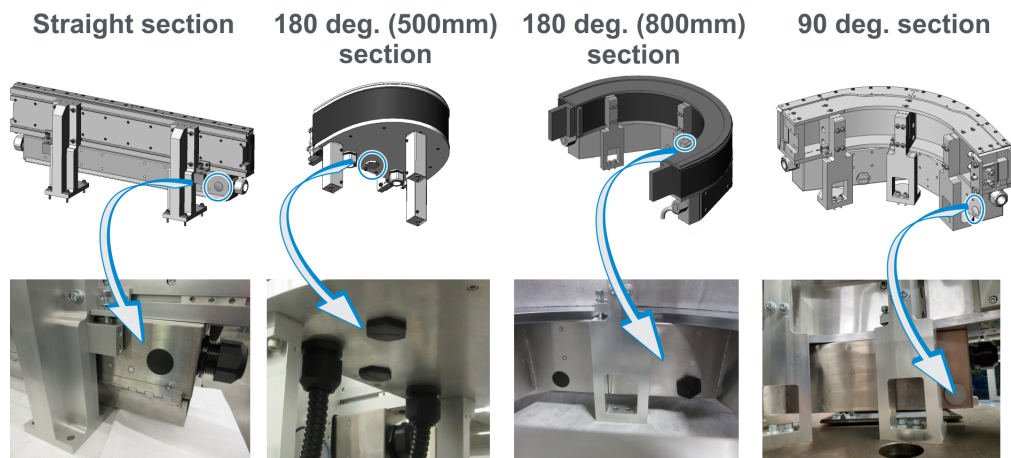

- e. Proceed to step 5.
4. If you are replacing an existing power supply:
  - a. Remove the four (4) screws that secure it to the mounting plate.
  - b. Disconnect the power supply wire connections from the SuperTrak conveyance platform (not from the power supply).
5. Secure the new power supply to the mounting plate with one (1) screw in each of the four (4) mounting brackets.
6. As required, complete one (1) of the following to access the left coil driver board:
  - For all straight, 180 deg. (800 mm), and 90 deg. sections: Open the electrical door at the base of the section's motor.

- For 180 deg (500 mm) sections: Remove the top cover from the 180 deg. (500 mm) section. It may also be helpful to remove the panel on the back of the section.
7. Feed the 28 VDC power output cable through the plug opening (step 3d) and then tighten the connection.



8. Connect the power supply cables to the left coil driver board:

- a. Remove the screw from the top of the 50A fuse, and the screw from the common connection wire.

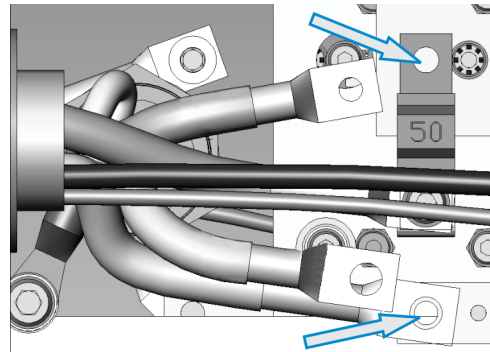

- b. Align the positive (+) 28VDC motor power wire of the power supply with the top of the 50A fuse.

- c. Secure the wire and fuse in position with a lock nut, washer, and screw.

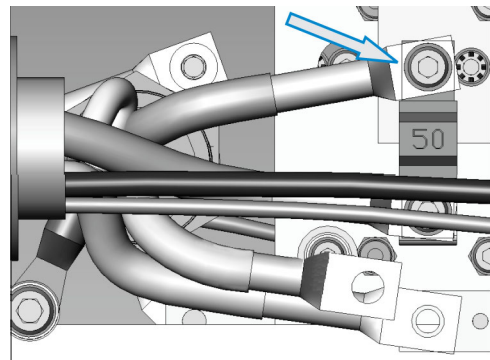

- d. Align the negative (-) common wire from the left electrical interconnect, and the negative (-) common wire of the power supply with the common connection.

These two (2) wires both have a white stripe on them.

- e. Repeat step 8c.
- f. Verify that the wiring is the same as the *Left Coil Driver Board with a Power Supply Connected* on page 29.

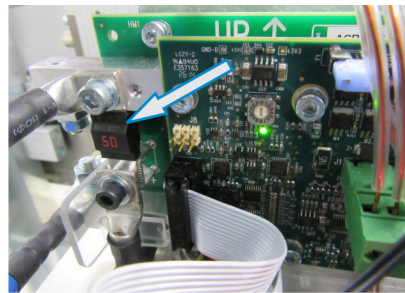
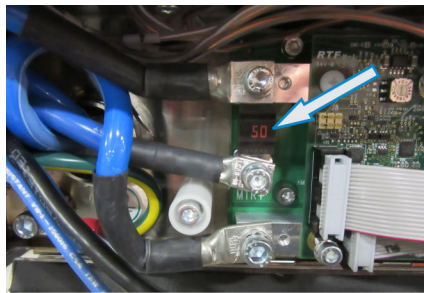
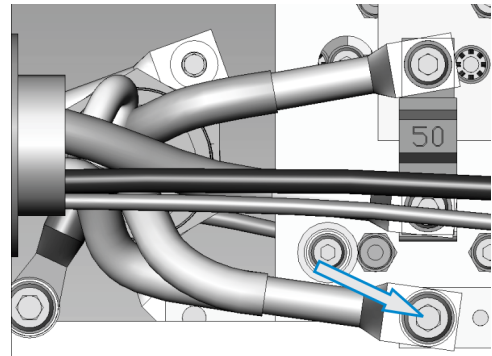

- 9. Feed the AC power input cable through the cable entry plate at the back of the control panel.

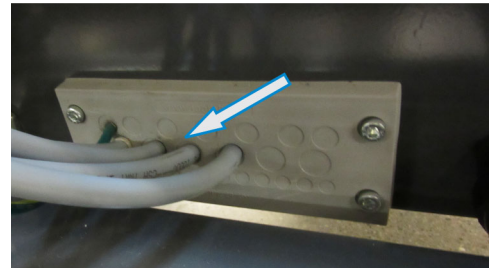



10. Connect the AC power input plug to the terminal strip (-X1) in the control panel.

The control panel can have six (6) or twelve (12) breakers. The base control panel includes six (6), with an option to increase to twelve (12).

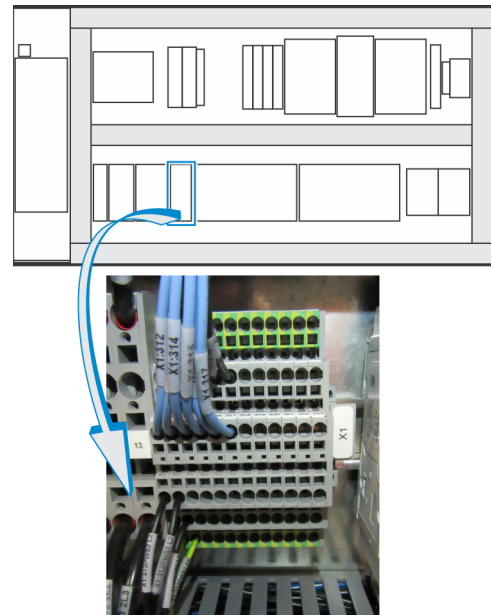

11. As required, complete one (1) of the following to connect the power supply OK signal:

- Connect the power supply OK signal to a field-mounted remote input block, for PLC monitoring.
- Connect to the control panel discrete input.

## Replace a Coil Driver Board

This section describes how to replace a coil driver board in a straight section or in a 180 deg. section.

### Remove a Coil Driver Board - Straight Section

**NOTICE**

To prevent electrical board damage from electrostatic discharge (ESD), use an ESD wrist strap when working with the coil driver board. An ESD wrist strap prevents the buildup of static electricity.

1. Turn the **SuperTrak conveyance platform power disconnect switch** to the OFF position.

2. Lock out and tag hazardous energy.

See [Lockout and Tagout Locations](#) on page 12.

3. Use a flat head screwdriver to unlock the five (5) locks, and then open the electrical door.

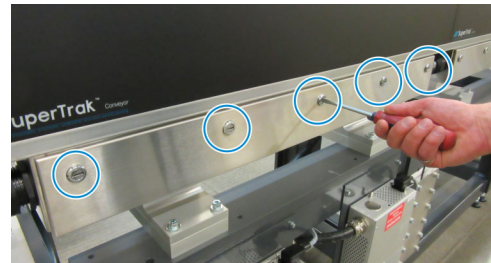

4. Unplug the two (2) ribbon cables.  
Pull each of the four (4) ribbon cable plugs straight out.

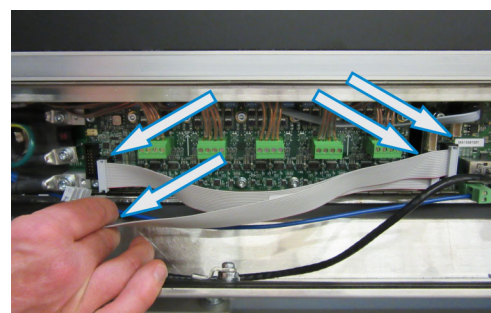

5. Unplug the five (5) coil plugs.  
Pull each coil plug straight out.

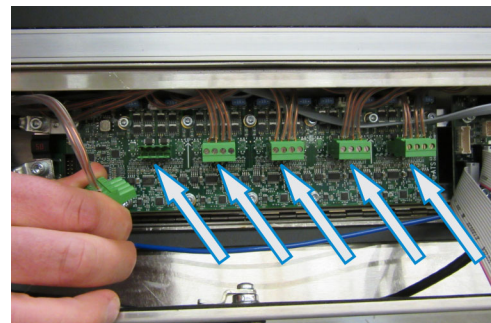

6. Remove the fourteen (14) screws that secure the coil driver board to the bus bar.  
Note that one (1) screw is nylon. This screw is located in the upper-left corner of the coil driver board.

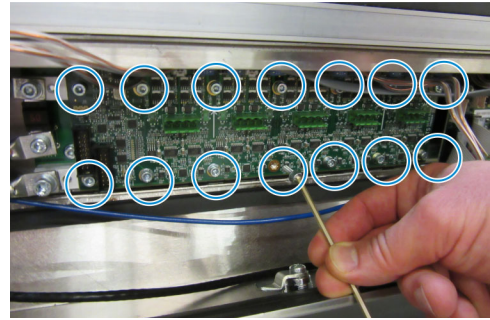

7. Pull the coil driver board straight down and out, and then disconnect the five (5) thermistor connections.  
Squeeze the tabs for each thermistor connector plug and then pull straight out.

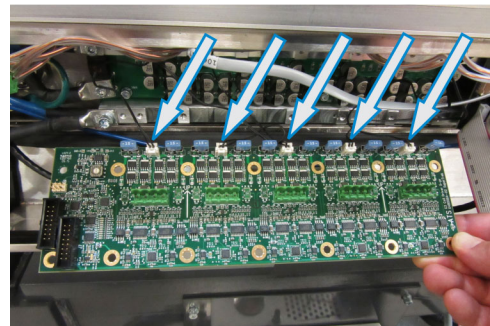

## Remove a Coil Driver Board - 180 Deg. Section (500 mm)

**NOTICE**

To prevent electrical board damage from electrostatic discharge (ESD), use an ESD wrist strap when working with the coil driver board. An ESD wrist strap prevents the buildup of static electricity.

1. Turn the **SuperTrak conveyance platform power disconnect switch** to the OFF position.
2. Lock out and tag hazardous energy.  
See [Lockout and Tagout Locations](#) on page 12.

3. Remove ten (10) screws and ten (10) washers from the top cover of the 180 deg. section, and then lift and remove the top cover.

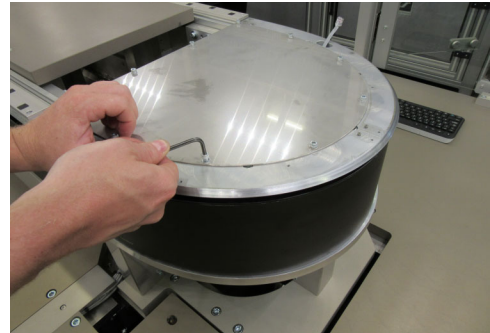

4. Unplug the two (2) ribbon cables.  
Pull each of the four (4) ribbon cable plugs straight out.

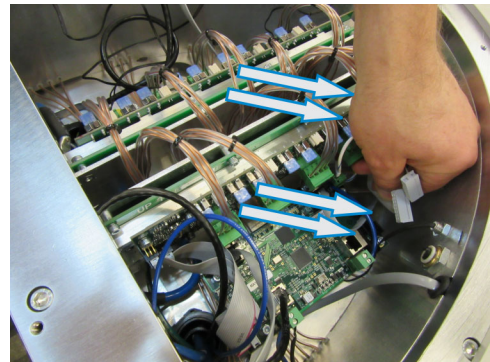

5. Unplug the five (5) coil plugs.  
Pull each coil plug straight out.

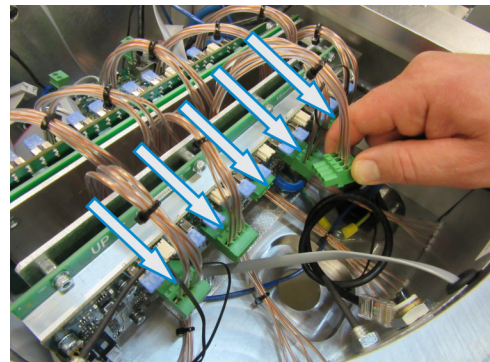

- Remove the fourteen (14) screws that secure the board to the bus bar.

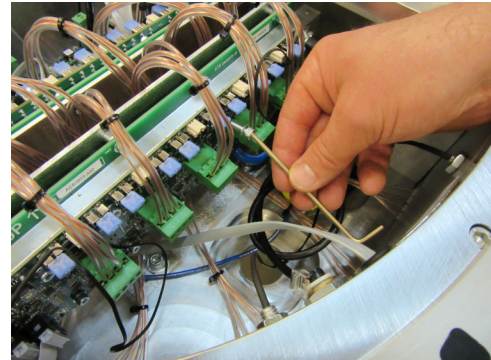

- Disconnect the three (3) thermistor connections.  
Squeeze the tabs for each thermistor connector plug and then pull straight out.

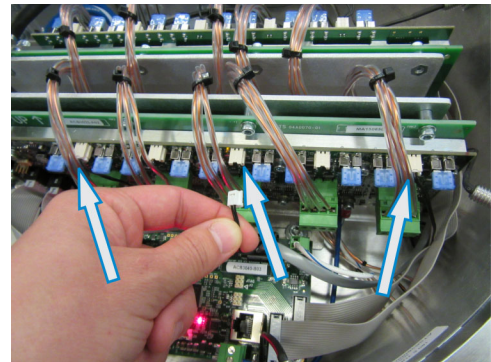

- Lean the coil driver board forward and lift straight up.

### Remove a Coil Driver Board - 180 Deg. Section (800 mm) or 90 Deg. Section

**NOTICE**

To prevent electrical board damage from electrostatic discharge (ESD), use an ESD wrist strap when working with the coil driver board. An ESD wrist strap prevents the buildup of static electricity.

- Turn the **SuperTrak conveyance platform power disconnect switch** to the OFF position.
- Lock out and tag hazardous energy.  
See [Lockout and Tagout Locations](#) on page 12.
- Use a flat head screwdriver to remove the screws from the electrical door, and then set the electrical door aside.
- Remove the gateway board.  
Complete steps 4 to 9 of the [Remove a Gateway Board - Straight Section, 90 Deg. Section, or 180 Deg. \(800 mm\) Section](#) on page 157.
- Remove the coil driver board.  
Complete steps 4 to 7 of the [Remove a Coil Driver Board - Straight Section](#) on page 150.

## Install a Coil Driver Board - Straight Section, 180 Deg. Section (800 mm), or 90 Deg. Section

### NOTICE

- To prevent electrical board damage from electrostatic discharge (ESD), use an ESD wrist strap when working with the coil driver board. An ESD wrist strap prevents the buildup of static electricity.
- During installation, do not pinch any wires behind the coil driver board when screws are installed. This can cause an electrical short.

If required, reference [Straight Section - Left Coil Driver Board](#) on page 28 during this procedure.

1. Remove the old coil driver board.  
See [Remove a Coil Driver Board - Straight Section](#) on page 150.
2. Inspect the new coil driver board, to make sure it contains ten (10) 15 A fuses.
3. Connect the five (5) thermistor connections.
4. Align the coil driver board with the screw holes inside the straight section or curved section.

Make sure there are no wires behind the coil driver board.

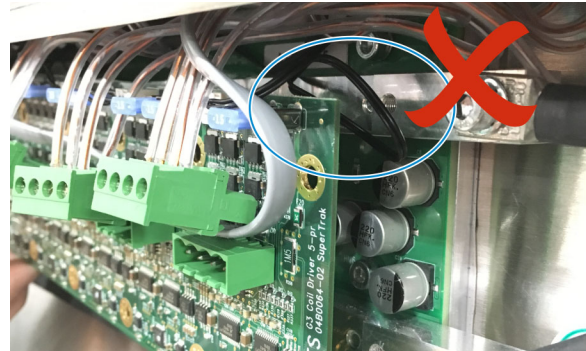

5. Secure the coil driver board in position with fourteen (14) screws. Make sure that the screw in the upper-left corner of the coil driver board is nylon, and that the coil driver board wires are clear of the screws.

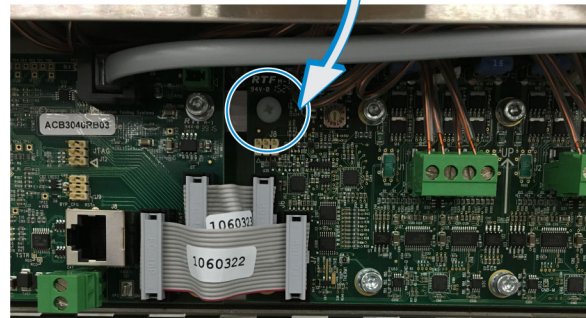
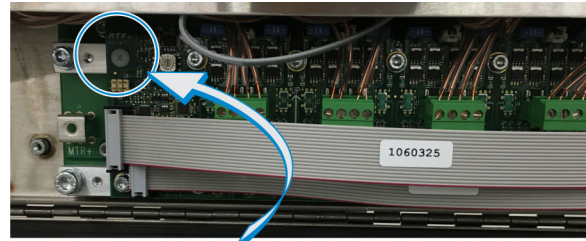

6. Connect the five (5) coil plugs.
7. Connect the two (2) ribbon cables.

## Install a Coil Driver Board - 180 Deg. Section (500 mm)

### NOTICE

- To prevent electrical board damage from electrostatic discharge (ESD), use an ESD wrist strap when working with the coil driver board. An ESD wrist strap prevents the buildup of static electricity.
- During installation, take care not to pinch wires when the coil driver board screws are installed. This can cause an electrical short.

If required, reference [Straight Section - Left Coil Driver Board](#) on page 28, and [Left Coil Driver Board with a Power Supply Connected](#) on page 29 during this procedure.

1. Remove the old coil driver board.

See [Remove a Coil Driver Board - 180 Deg. Section \(500 mm\)](#) on page 152.

2. Inspect the new coil driver board, to make sure it contains ten (10) 15 A fuses.
3. Align the coil driver board with the screw holes inside the straight section or 180 deg. section.
4. Secure the coil driver board in position with fourteen (14) screws.

Make sure that the screw in the upper left corner of the coil driver board is nylon.

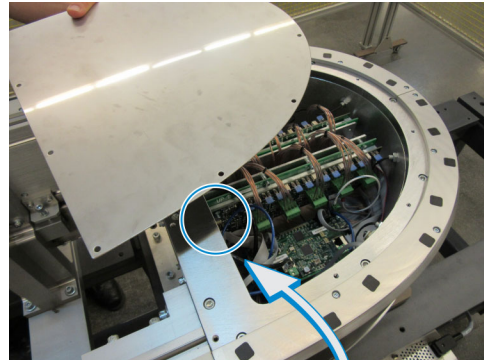

5. Connect the five (5) coil plugs.
6. Connect the two (2) ribbon cables.
7. Connect the three (3) thermistor connections.



## Replace a Gateway Board

This section describes how to replace a gateway board in a straight section, 90 deg. section, or in a 180 deg. section

### Remove a Gateway Board - Straight Section, 90 Deg. Section, or 180 Deg. (800 mm) Section

**NOTICE**

To prevent electrical board damage from electrostatic discharge (ESD), use an ESD wrist strap when working with the gateway board. An ESD wrist strap prevents the buildup of static electricity.

1. Turn the **SuperTrak conveyance platform power disconnect switch** to the OFF position.

2. Lock out and tag hazardous energy.

See [Lockout and Tagout Locations](#) on page 12.

3. Use a flat head screwdriver to unlock the lock screws to open the electrical door access.

- *Straight section (pictured at right)*--there are five lock screws on the access door.

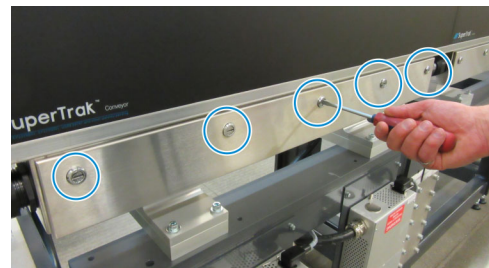

- *180 deg. (800 mm) section*--there are two gateway boards, one in the right and one in the left electrical compartment. Unlock the four screws on the access door where the gateway board you want to replace is located.

- *90 deg. section*--the gateway board is located in the left of the two electrical compartments. Unlock the six screws on the left-side access door.

4. Unplug the two (2) 24V digital power connections.

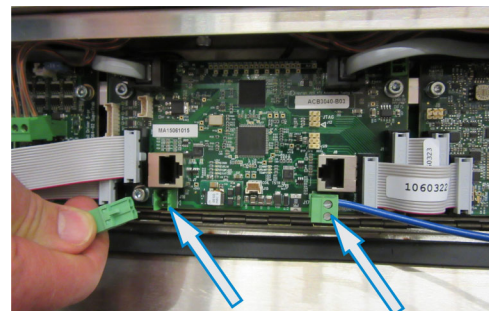

5. As required, unplug one (1) or two (2) motor network connection cables.

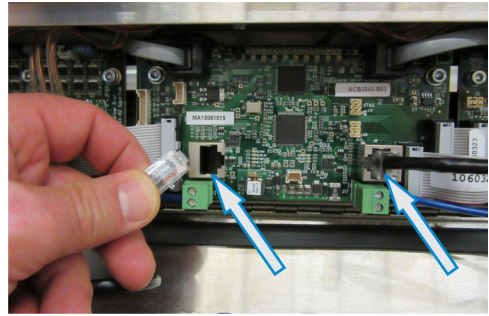

6. Unplug the four (4) ribbon cables.

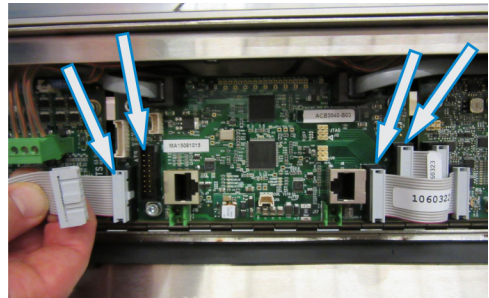

7. Disconnect the two (2) encoder cables (right and left).

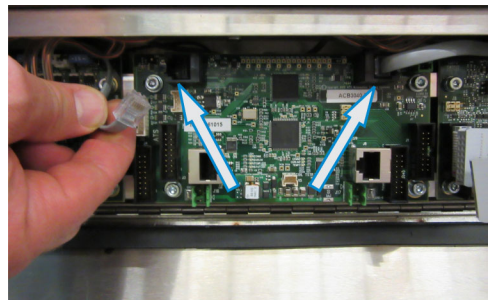

8. Loosen, do not remove, all four (4) connection screws.

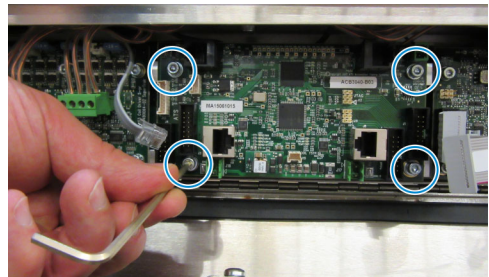

9. Remove the gateway board.

As illustrated, verify that three (3) white plastic spacers are connected to each screw.

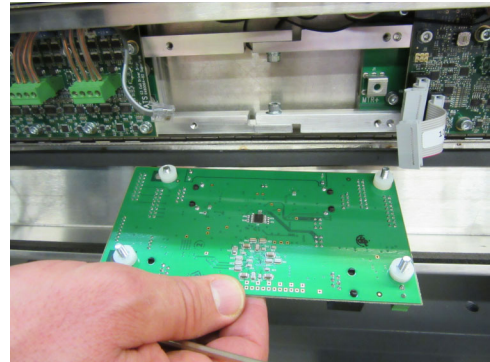

10. If the gateway board is being returned for repair, remove the hardware (screws, washers, and spacers), and make sure the gateway board is packaged in an ESD safe bag.

## Remove a Gateway Board - 180 Deg. Section (500 mm)

**NOTICE**

To prevent electrical board damage from electrostatic discharge (ESD), use an ESD wrist strap when working with the gateway board. An ESD wrist strap prevents the buildup of static electricity.

1. Turn the **SuperTrak conveyance platform power disconnect switch** to the OFF position.
2. Lock out and tag hazardous energy.  
See [Lockout and Tagout Locations](#) on page 12.

3. Remove ten (10) screws and ten (10) washers from the top cover of the 180 deg. section, and then lift and remove the top cover.

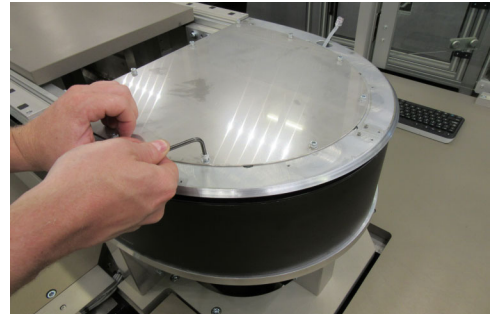

4. Disconnect the two (2) 24V digital power connections.

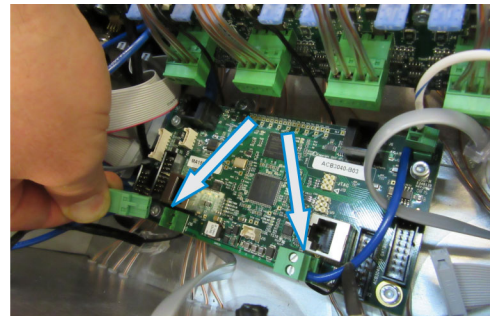

5. Unplug the four (4) ribbon cables.

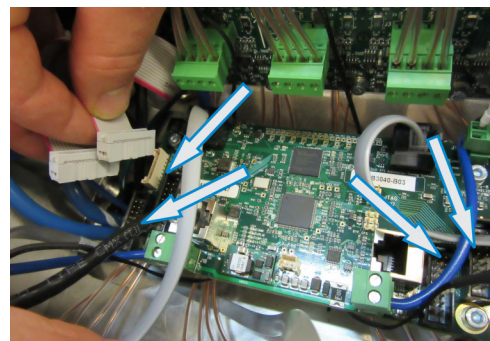

6. Unplug the two (2) encoder cables (right and left).

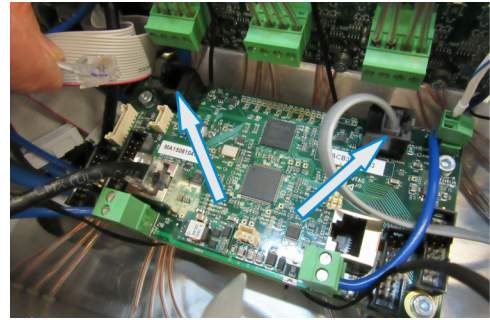

7. As required, unplug one (1) or two (2) motor network connection cables.

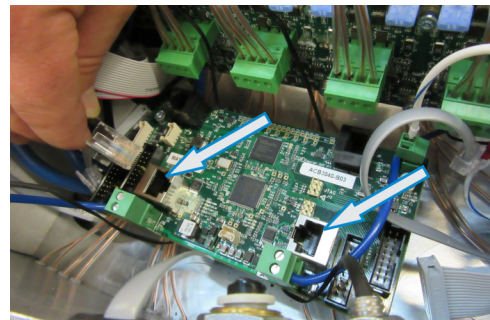

8. Disconnect the ground wire.

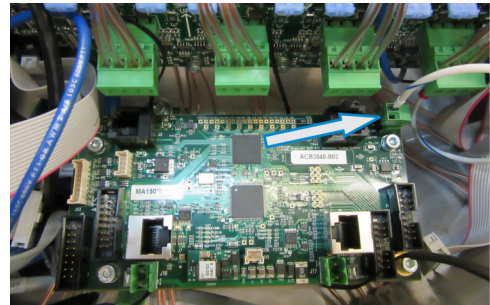

9. Remove the four (4) connection screws.

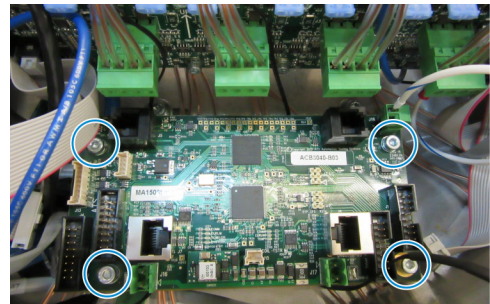

10. Remove the gateway board.
11. If the gateway board is being returned for repair, remove the hardware (screws, washers, and spacers), and make sure the gateway board is packaged in an ESD safe bag.

## Install a Gateway Board - Straight Section, 90 Deg. Section, or 180 Deg. (800 mm) Section

**NOTICE**

To prevent electrical board damage from electrostatic discharge (ESD), use an ESD wrist strap when working with the gateway board. An ESD wrist strap prevents the buildup of static electricity.

If required, reference *Gateway Board* on page 30 during this procedure.

1. Remove the old gateway board:  
See *Remove a Gateway Board - Straight Section, 90 Deg. Section, or 180 Deg. (800 mm) Section* on page 157.
2. Assemble the gateway board:
  - a. Install a toothed washer on each of the four (4) screws.
  - b. Install flat washer on each of the four (4) screws.
  - c. Insert each of the four (4) screws through the gateway board.
  - d. Install three (3) white plastic spacers on the end of each of the four (4) screws.  
Make sure the spacers are within a thread or two of the end of the screw.
3. Align the screws in the gateway board with the threaded holes inside the straight section.

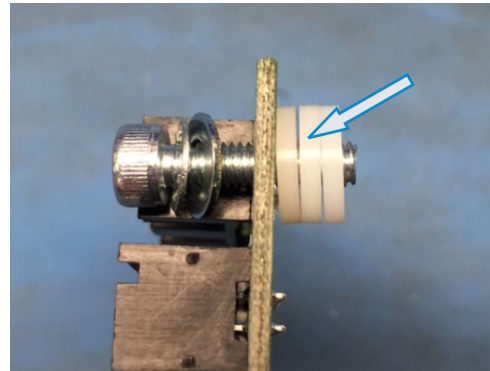

4. On each of the four (4) corners of the gateway board, verify that the gateway board sits flat on the white plastic spacers.

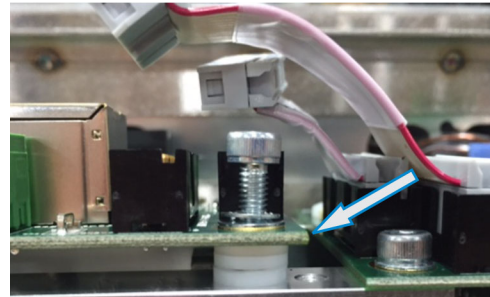

5. Secure the gateway board in position with four (4) screws. To prevent distortion of the gateway board, tighten one (1) screw at a time, working around the board in a clockwise direction.

Depending on how the screws and white spacers bind, it may be necessary to tighten each screw a thread at a time.

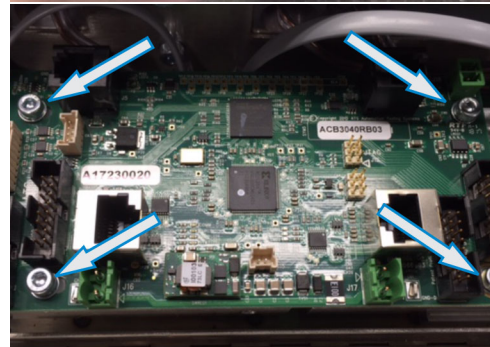

6. Torque each of the four (4) screws to 18 lbf-in (2 Nm).

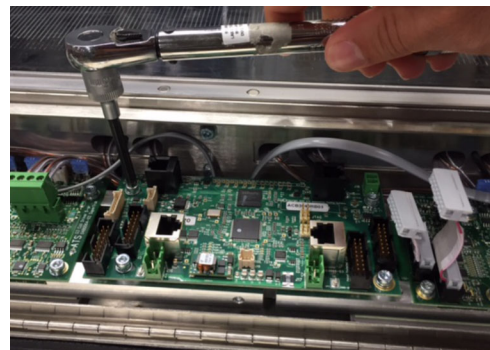

7. Reconnect the cables to the gateway board:

- a. Connect the two (2) encoder cables (right and left).
- b. Connect the four (4) ribbon cables.
- c. As required, connect one (1) or two (2) motor network connection cables.
- d. Connect the two (2) 24V digital power connections.

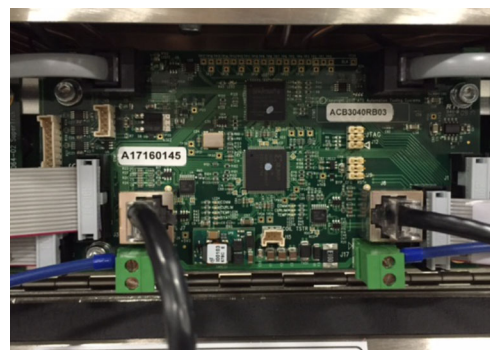

8. Close the electrical door, and then lock the five (5) locks with a flat head screwdriver.

## Install a Gateway Board - 180 Deg. Section (500 mm)

**NOTICE**

To prevent electrical board damage from electrostatic discharge (ESD), use an ESD wrist strap when working with the gateway board. An ESD wrist strap prevents the buildup of static electricity.

If required, reference [Gateway Board](#) on page 30 during this procedure.

1. Remove the old gateway board:  
See [Remove a Gateway Board - 180 Deg. Section \(500 mm\)](#) on page 160.
2. Verify that the gateway board does not contain any white plastic spacers, and then align the gateway board with the screw holes inside the 180 deg. section.
3. Secure the gateway board in position with four (4) screws.
4. Connect the ground wire.
5. As required, connect one (1) or two (2) motor network connection cables.
6. Connect the two (2) encoder cables (right and left).
7. Connect the four (4) ribbon cables.
8. Connect the two (2) 24V digital power connections.
9. Align the top cover on the 180 deg. section.
10. Install ten (10) screws and ten (10) washers to secure the top cover in position.



## Replace an Encoder Assembly

A 180 deg. (800 mm) section has four (4) encoder assemblies, while all other curved and straight sections have two (2) encoder assemblies. Replace the encoder assembly if a SuperTrak conveyance platform fault indicates that replacement is required.

### Remove an Encoder Assembly - Straight Section

1. Turn the **SuperTrak conveyance platform power disconnect switch** to the OFF position.
2. Lock out and tag hazardous energy.  
See [Lockout and Tagout Locations](#) on page 12.
3. Remove the five (5) encoder assembly screw caps.

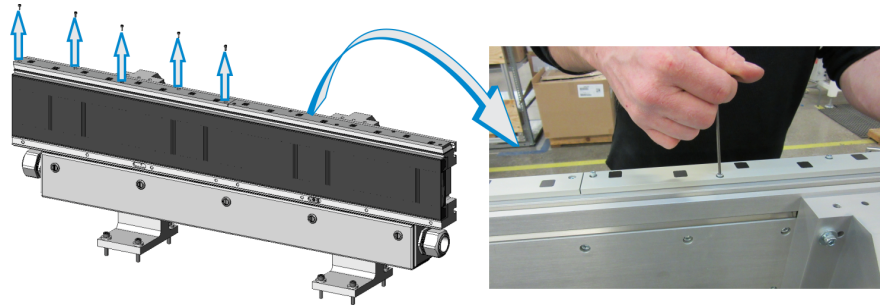

4. Remove the five (5) encoder assembly screws.
5. Lift the encoder assembly straight up, off the two locating dowels.

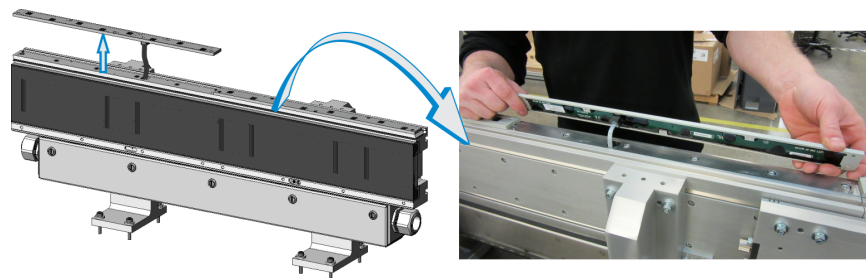

6. Disconnect the RJ11 plug from the encoder assembly connection.

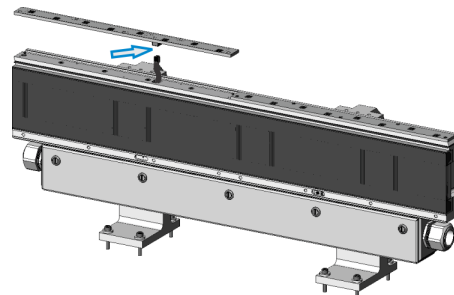

### Remove an Encoder Assembly - Curved Sections

1. Turn the **SuperTrak conveyance platform power disconnect switch** to the OFF position.
2. Lock out and tag hazardous energy.  
See *Lockout and Tagout Locations* on page 12.
3. Remove the five (5) encoder assembly screw caps.  
*Note: The images in these instructions show the 180 deg. (500 mm) section, but the process is the same for other curved sections.*

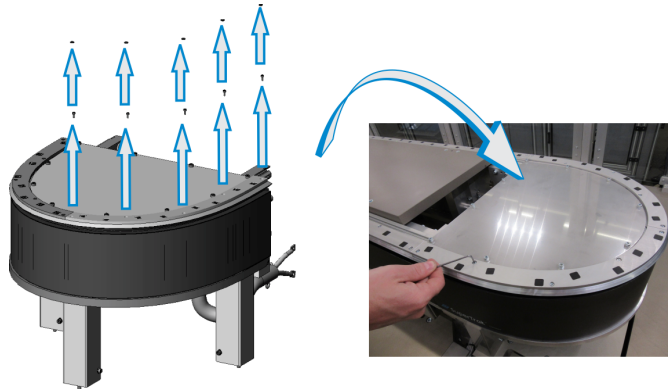

4. Remove the five (5) encoder assembly screws.
5. Lift the encoder assembly straight up, off the two locating dowels.

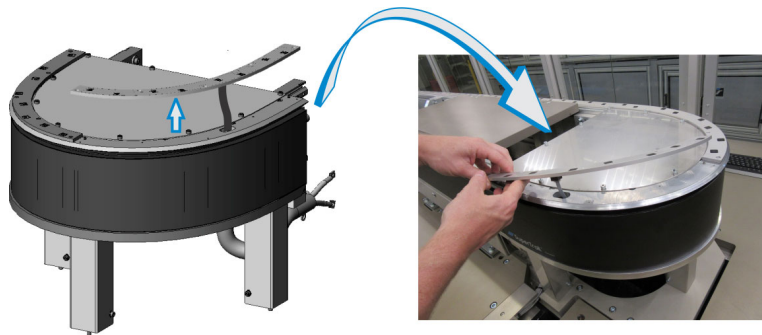

6. Disconnect the RJ11 plug from the encoder assembly connection.

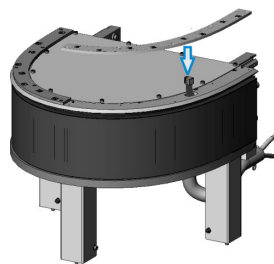

## Install an Encoder Assembly - Straight and Curved Sections

Power to the controller and gateways should OFF while installing encoders, and then turned ON before calibration.

1. If required, remove the old encoder assembly.  
See [Remove an Encoder Assembly - Straight Section](#) on page 165.  
See [Remove an Encoder Assembly - Curved Sections](#) on page 166.
2. Connect the RJ11 plug to the new encoder assembly connection.
3. Align the encoder assembly with the locating dowels.
4. To prevent damage to the RJ11 connection, make sure it is aligned with the RJ11 opening.
5. Press the encoder assembly firmly down onto the locating dowels.
6. Secure the encoder assembly in position with five (5) screws.
7. Install an encoder assembly screw cap over each of the five (5) screws.
8. Remove locks and tags.
9. Turn the **SuperTrak conveyance platform power disconnect switch** to the ON position.
10. Calibrate the motor with the new encoder assembly.  
See the TrakMaster built-in help for the calibration procedure.
11. If the straight section has a pallet setup stationary mount installed, reference the encoder positions.  
See [Reference the Encoder Position](#) on page 225.

## Replace a Motor Thermistor



A thermistor replacement fault can be set to be ignored in the TrakMaster software. This allows the SuperTrak conveyance platform to continue to run until the thermistor can be replaced at a convenient time.

See the TrakMaster built-in help for additional information.

Motor thermistor connections are made with the coil driver boards. Replace a motor thermistor if a SuperTrak conveyance platform fault indicates that replacement is required.

### Replace a Mid-Section Thermistor - Straight Section, 90 Deg. Section, or 180 Deg. Section (800 mm)

There are ten (10) thermistors in each straight section: five (5) on the left coil driver board, and five (5) on the right coil driver board. This section describes how to replace the the 2nd-9th thermistors

1. Turn the **SuperTrak conveyance platform power disconnect switch** to the OFF position.
2. Lock out and tag hazardous energy.

See [Lockout and Tagout Locations](#) on page 12.

3. Open the section's electrical door.
4. If access to the motor thermistor is blocked, disconnect the applicable coil connection.

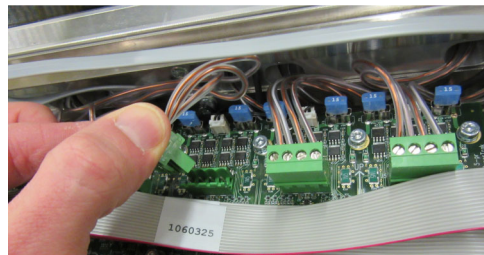

5. Unplug the thermistor connector from the coil driver board.

To unplug the thermistor connector, use the index finger from each hand (left image), or your thumb and index finger (right image).

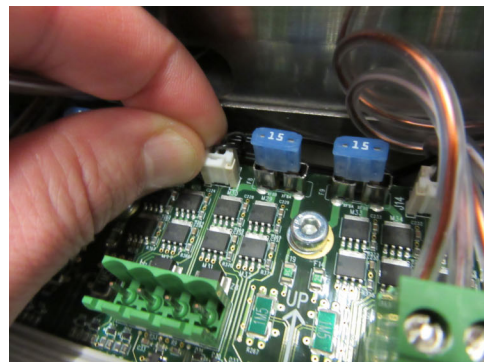
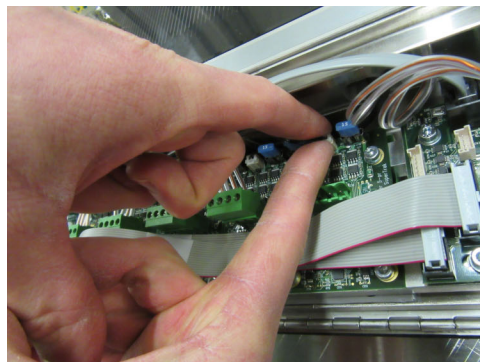

- Pull the old thermistor wire straight out from the thermistor hole.

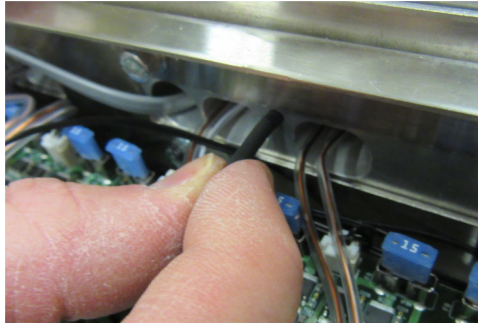

- Slide the end of the new thermistor wire into the thermistor hole until you feel resistance.

The thermistor tapers. During installation, the thick ridge creates a friction fit against the sides of the thermistor hole.

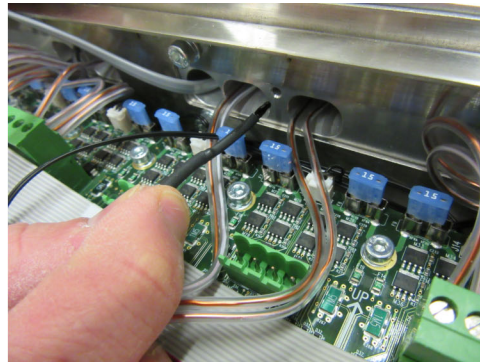
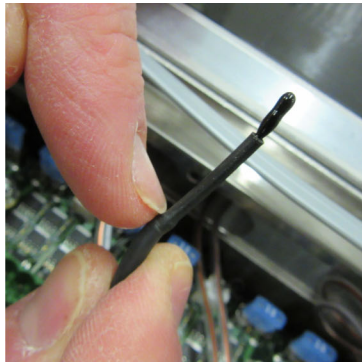

- Plug the new thermistor connector into the electrical board.
- Route the thermistor wire under the electrical board.
- If required, connect any coil connections that were disconnected in step 4.

### Replace the Outer Thermistors in a Straight Section

There are ten (10) thermistors in each straight section: five (5) on the left coil driver board, and five (5) on the right coil driver board. This section describes how to replace the the 1st & 10th thermistors

- Turn the **SuperTrak conveyance platform power disconnect switch** to the OFF position.
- Lock out and tag hazardous energy.

See [Lockout and Tagout Locations](#) on page 12.

3. Open the straight section electrical door.  
Access to the motor thermistor, which is located through the small hole in the cabinet (A), is blocked by the electrical interconnect (B).

Remove the electrical interconnect.

See [Replace an Electrical Interconnect](#) on page 176.

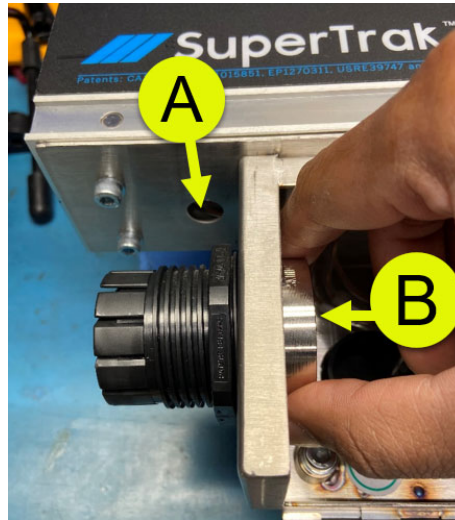

4. Once the electrical interconnect is removed, look for the motor thermistor and wire through the hole in the cabinet. Use needle-nose pliers to gently pull the wire through the hole..



5. Replace the thermistor at the end of the wire.

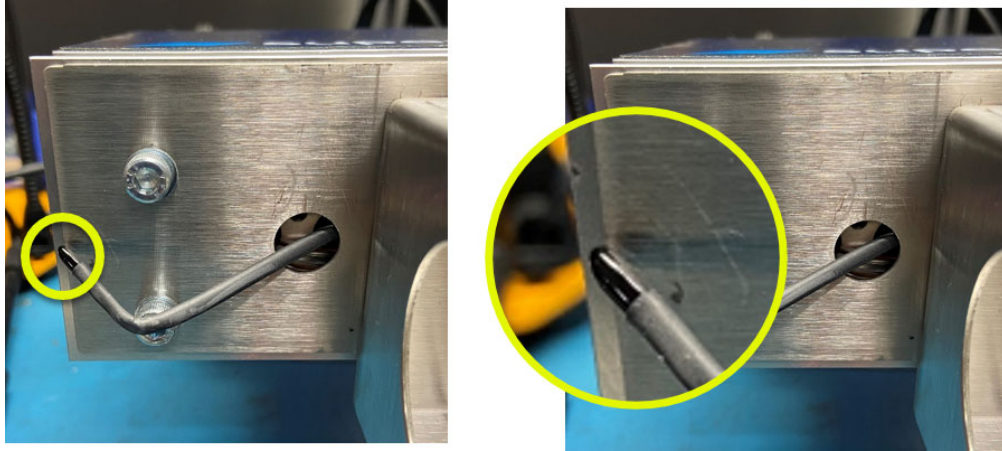

6. Thread the wire with the new thermistor back through the hole in the cabinet.
7. Reinstall the electrical interconnect.

### Replace a Thermistor - 180 Deg. Section (500 mm)

There are six (6) thermistors in each 180 deg. section.

1. Turn the **SuperTrak conveyance platform power disconnect switch** to the OFF position.
2. Lock out and tag hazardous energy.  
See *Lockout and Tagout Locations* on page 12.
3. Remove the 180 deg. section top cover.

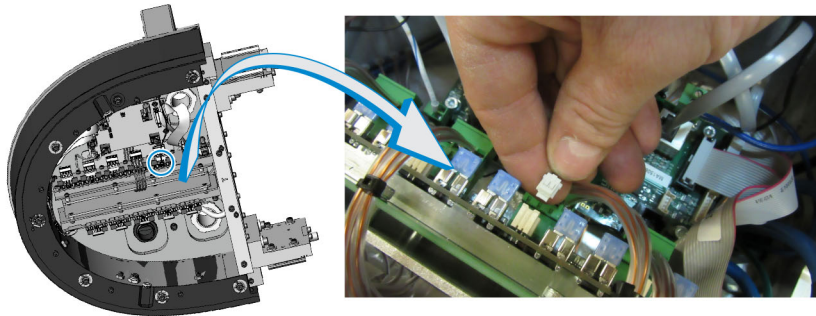

4. Unplug the thermistor connector from the coil driver board.
5. Pull the old thermistor wire straight out from the thermistor hole.

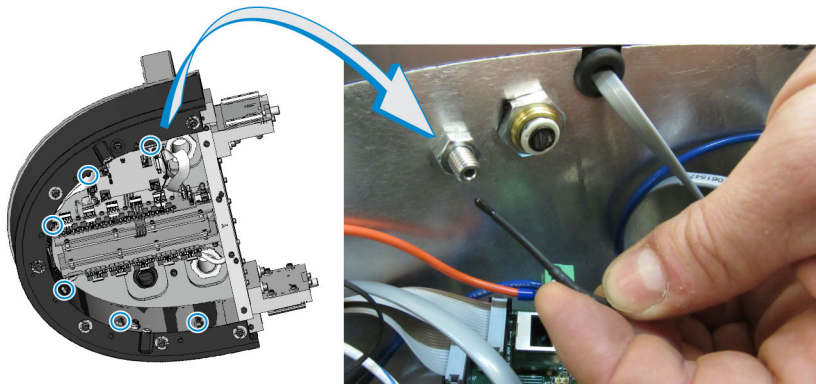

6. Slide the end of the new thermistor wire into the thermistor hole until you feel resistance.

The thermistor tapers. During installation, the thick ridge creates a friction fit against the sides of the thermistor hole

7. Plug the new thermistor connector into the electrical board.
8. Route the thermistor wire under the electrical board.



## Replace the Main Motor Fuse

A 50A fuse is installed on the left coil driver board when a power supply is installed for the motor. The 50A fuse bridges the two (2) 28VDC motor power connections. Fuse replacement may be required if a low motor voltage fault displays.

1. Turn the **SuperTrak conveyance platform power disconnect switch** to the OFF position.
2. Lock out and tag hazardous energy.  
See [Lockout and Tagout Locations](#) on page 12.
3. As required, complete one (1) of the following to access the left coil driver board:
  - For all straight, 180 deg. (800 mm), and 90 deg. sections: Open the electrical door at the base of the section's motor.
  - For 180 deg (500 mm) sections: Remove the top cover from the 180 deg. (500 mm) section. It may also be helpful to remove the panel on the back of the section.
4. Remove a screw from each of the two (2) 28VDC motor power connections.

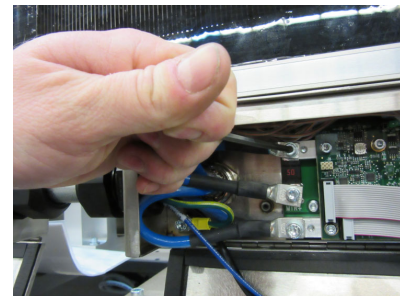

5. Remove the 50A fuse.
6. Align a new 50A fuse with the two (2) 28VDC motor power connections.

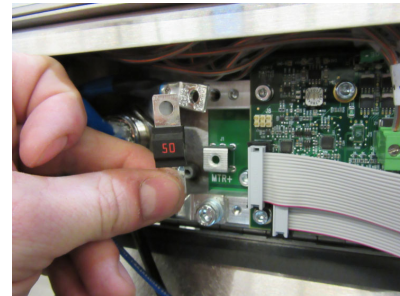

7. Install a screw through each of the two (2) 28VDC motor power connections and into the 50A fuse.

Make sure each screw has a washer and lock nut as illustrated.



## Replace a Coil Fuse



It is possible for the SuperTrak conveyance platform to operate when a coil fuse is blown; however, the pallet stop control is affected.

Each coil driver board has ten (10) 15A fuses; there is a dedicated fuse for each coil. If a SuperTrak conveyance platform fault indicates that fuse replacement is required, remove the fuse and test it. If the fuse is blown, replace it. If the fuse is not blown, verify that the fuse is seated correctly.

The images below indicate correct and incorrect fuse installation.

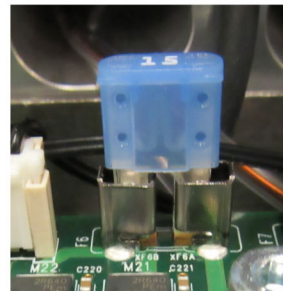
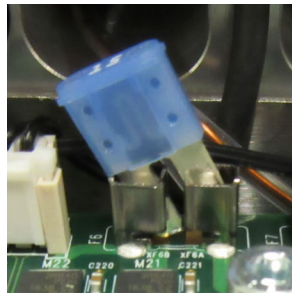

### Replace a Coil Fuse - Straight Section, 90 Deg. Section, or 180 Deg. Section (800 mm)

1. Turn the **SuperTrak conveyance platform power disconnect switch** to the OFF position.
2. Lock out and tag hazardous energy.  
See [Lockout and Tagout Locations](#) on page 12.
3. Open the electrical door at the base of the straight section.
4. If access to the fuse is blocked, disconnect the applicable coil connection.

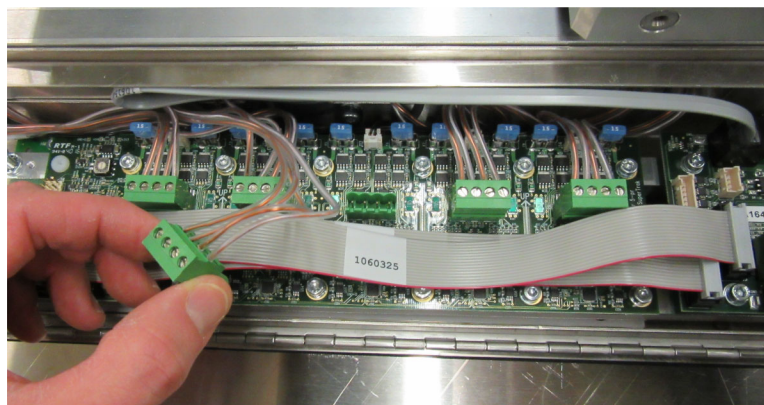

5. Pull the 15A fuse straight out from the slot.

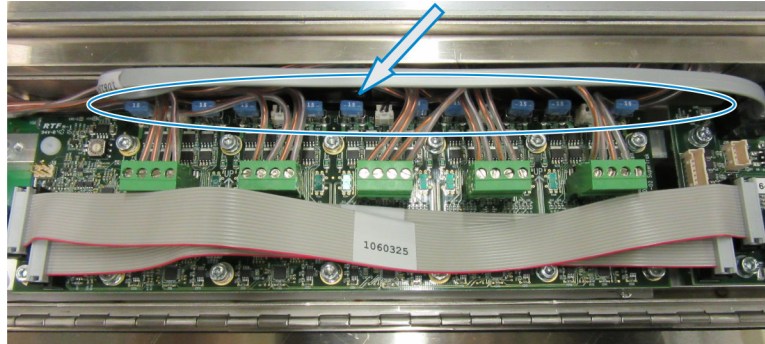

6. Install a new 15A fuse straight into the fuse slot.  
Make sure the fuse is centered and seated correctly during installation.
7. If required, connect any coil connections that were disconnected in step 4.

### Replace a Coil Fuse - 180 Deg. Section (500 mm)

1. Turn the **SuperTrak conveyance platform power disconnect switch** to the OFF position.
2. Lock out and tag hazardous energy.  
See [Lockout and Tagout Locations](#) on page 12.
3. Remove the top cover from the 180 deg. section.
4. Pull the 15A fuse straight out from the slot.

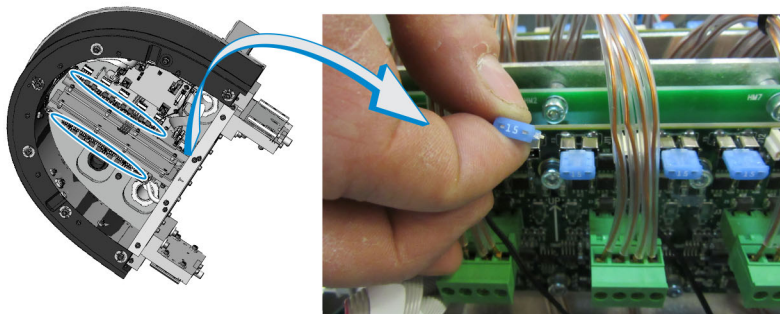

5. Install a new 15A fuse straight into the fuse slot.  
Make sure the fuse is centered and seated correctly during installation.

## Replace an Electrical Interconnect



For a wiring overview, see the wiring pin-out overview label located on the electrical door of each straight section and curved section during this procedure.

### Replace a Section-to-Section Electrical Interconnect--Rigid Connection

#### Remove the existing rigid conduit

1. Turn the **SuperTrak conveyance platform power disconnect switch** to the OFF position.
2. Lock out and tag hazardous energy.  
See [Lockout and Tagout Locations](#) on page 12.
3. Open the electrical doors of the two (2) adjacent sections.
4. Disconnect and remove all wires that run through the metal conduit.
5. Loosen the strain relief connectors on the side of the two (2) adjacent sections.
6. Slide the metal conduit out through the cable access hole.

Slide the metal conduit to the right, so it exits through the left side of the electrical panel.

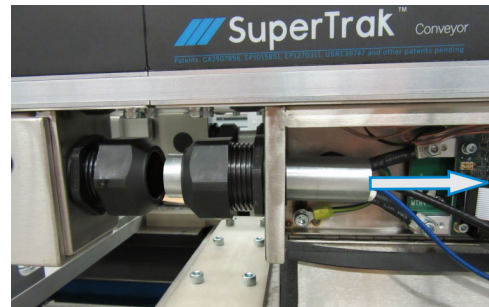

#### Install the replacement rigid conduit

1. If required, remove the existing electrical interconnect, as described above.
2. Slide the metal conduit in through the cable access hole and the two (2) strain relief connectors.

Always start the metal conduit from left side of the section's electrical panel.

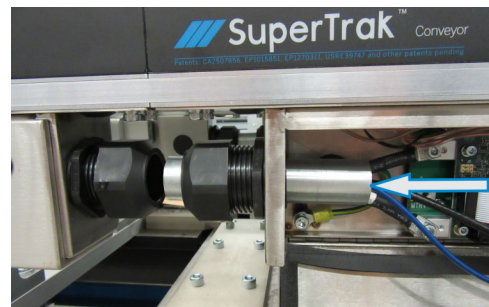

3. With the metal conduit flush with the strain relief connectors, tighten the two (2) strain relief connectors.

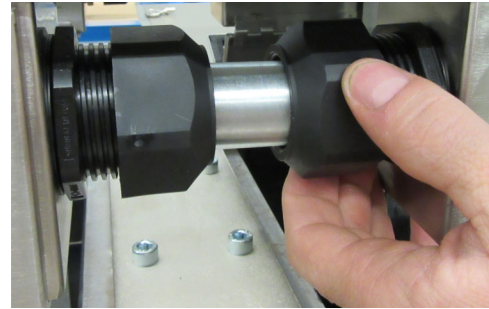

4. Feed the required wiring through the metal conduit and connect as required, then close the sections' electrical doors.

See [Straight Section - Left Coil Driver Board](#) on page 28 and [Right Coil Driver Board](#) on page 31 for connection information.

## Replace a Section-to-Section Electrical Interconnect--Flexible Connection

### Remove the existing flexible conduit

1. Turn the **SuperTrak conveyance platform power disconnect switch** to the OFF position.
2. Lock out and tag hazardous energy.  
See [Lockout and Tagout Locations](#) on page 12.
3. Access the interior of the sections by:
  - For 180 deg. (500 mm) sections, remove screws and washers from the top cover of the section, and then lift and remove the top cover.
  - For all other types of sections, use a flat head screwdriver to unlock the locks, and then open the electrical door.
4. Disconnect and remove all wires that run through the flexible conduit.
5. Loosen the strain relief connectors on the bottom of both adjacent sections.
6. Remove the flexible conduit.

### Install the replacement flexible conduit

1. If required, remove the existing electrical interconnect as described above.
2. Carefully bend the flexible conduit, so that one end is in each of the adjacent section's strain relief connectors.

3. Tighten the two (2) strain relief connectors.
4. Feed the required wiring through the metal conduit and connect as required, then replace the sections' electrical doors and/or top covers.

See *Straight Section - Left Coil Driver Board* on page 28, *Right Coil Driver Board* on page 31, *180 Deg. Section (500 mm)* on page 32, and *180 Deg. Section (800 mm)* on page 34 for connection information.

## Install an Electrical Interconnect Between a Curved Section and a SuperTrak Control Panel

**⚠ CAUTION**

Use only ATS approved network cables for connecting the SuperTrak G3 Controller to the first section; otherwise, the system may operate incorrectly.

The electrical interconnect has four (4) wires on one end and five (5) wires on the other, it also includes a left network patch cable (not shown), an F-F coupler, and three (3) ferrites.

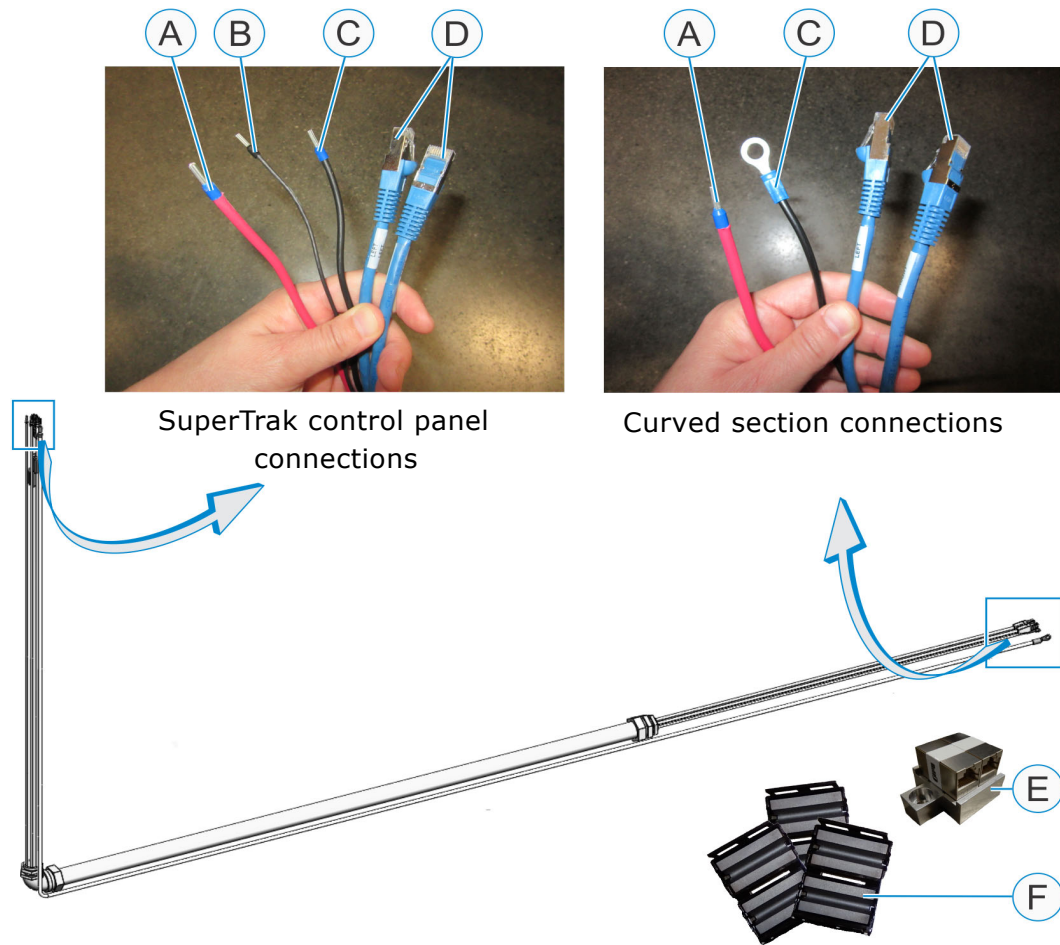

<b>A</b>	24VDC digital power (red or blue)	<b>D</b>	Ethernet cables - left and right network cables (blue)
<b>B</b>	Digital shield cable (black)	<b>E</b>	F-F coupler
<b>C</b>	Common connection (black or white with blue stripe)	<b>F</b>	Ferrite (1 of 3)

The procedure begins with connecting the end with four (4) wires to the curved section.

1. Install the F-F coupler:

a. As applicable, align the coupler with the mounting screw hole. Carefully lift the wires, so the F-F coupler fits below them:

- For the 180 deg. (500 mm) section, remove the top cover to access the mounting location.

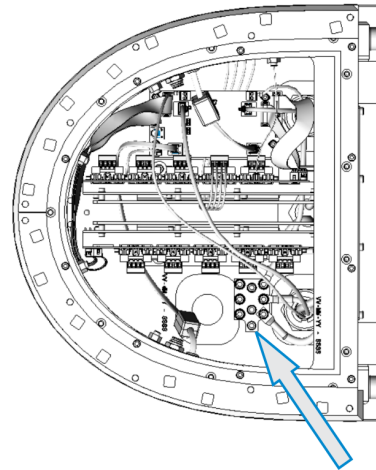

- For the 180 deg. (800 mm) section, remove the center electrical panel to access the mounting location.

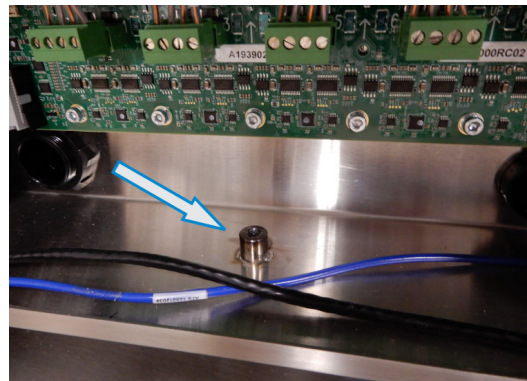

- For the 90 deg. section, remove the right side electrical panel to access the mounting location.

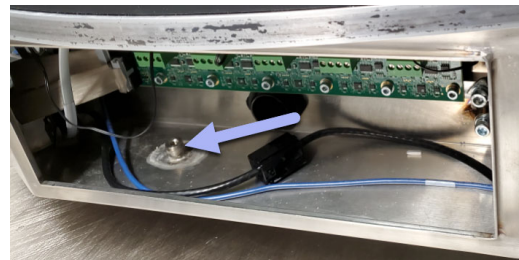



b. As applicable, secure the F-F coupler in position using a screw:

- For the 500 mm section, the F-F coupler installation is as shown at right.

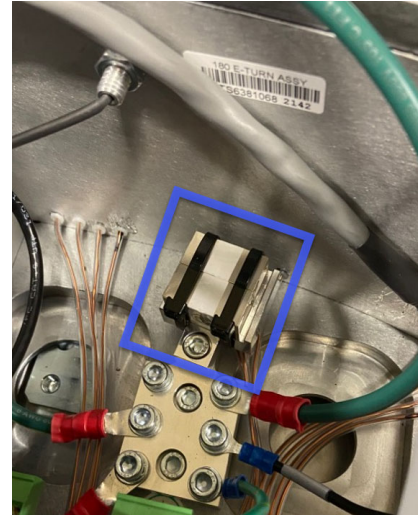

- For 180 deg. (800 mm) sections, the F-F coupler installation is as shown at right.

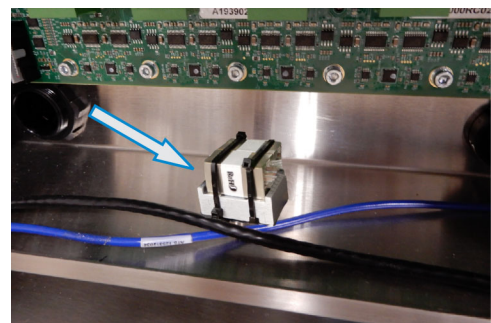

- For 90 deg. sections, the F-F coupler installation is as shown at right.

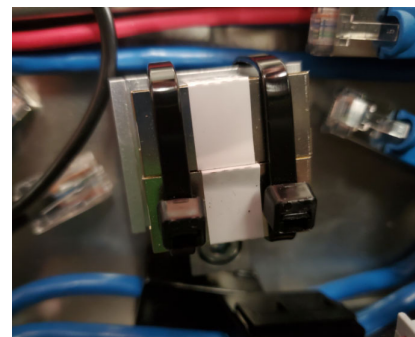

2. As applicable, remove the black wire plug from the curved section:

- For the 180 deg. (500 mm) section, the wire plug is located at the bottom.



- For the 180 deg. (800 mm) section, the wire plug is located on the back (inside).

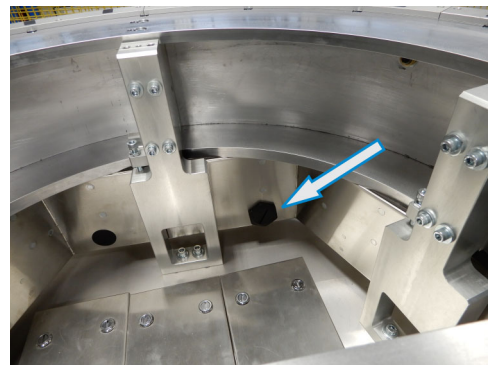

- For the 90 deg. section, the wire plug is located on the back (inside) at the bottom to the left of center.



3. Feed the four (4) cables of the interconnect cable through the plug opening on the curved section.
4. Secure the threaded end of the interconnect cable in the plug opening of the curved section using the supplied lock nut.

5. As applicable, connect the common connection wire (COM) to the curved section. Remove the mounting screw, align the common connection wire with the screw hole, and then reinstall the mounting screw:

- For the 180 deg. (500 mm) section, the connection is located near the bottom-right corner of the right coil driver board.

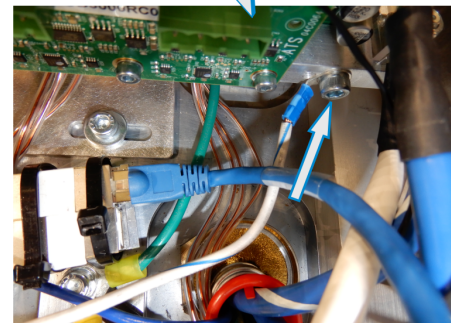
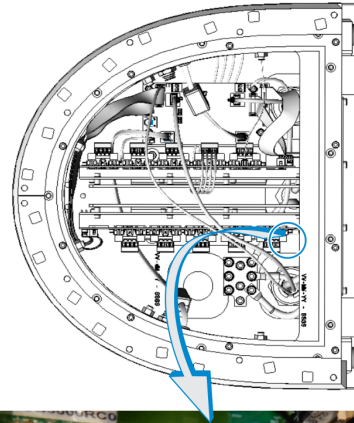

- For the 180 deg. (800 mm) section, the connection is located near the bottom-right corner of the right coil driver board that is in the center electrical panel.

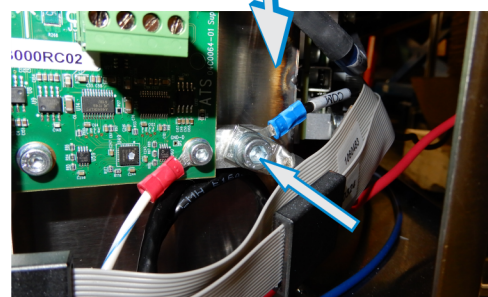
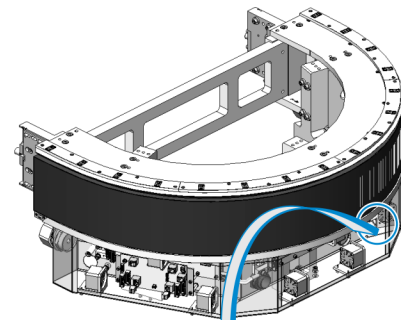

- For the 90 deg.section, the connection is located on the right side of the right coil driver board that is in the left electrical panel.

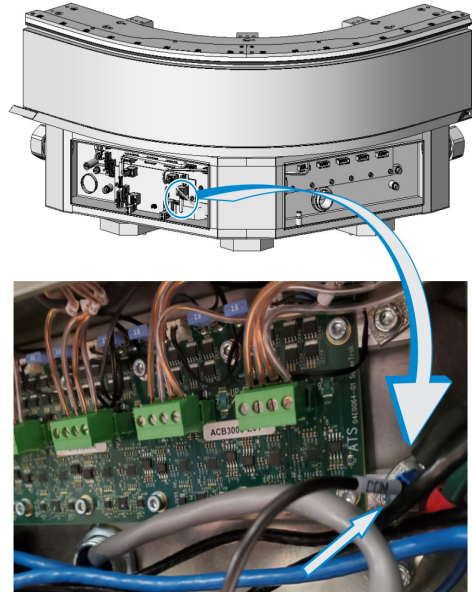

6. As applicable, connect the 24 VDC digital power wire (DIG+) to the J17 connector on the gateway board of the curved section:

- For the 180 deg. (500 mm) section, the connection is located on the gateway board inside the section.

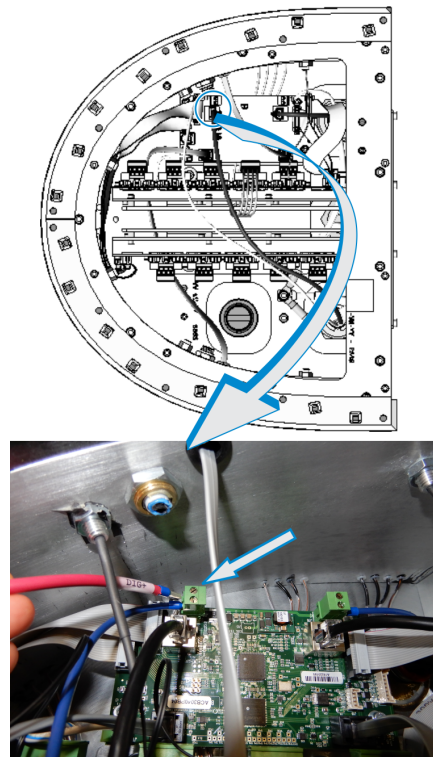

- For the 180 deg. (800 mm) section, the connection is located on the gateway board in the left electrical panel.

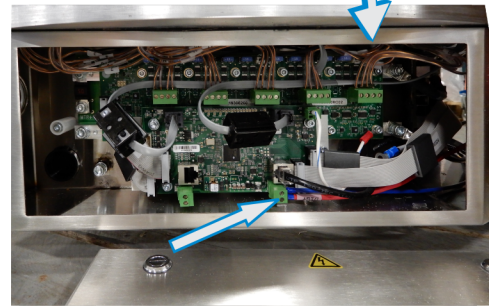
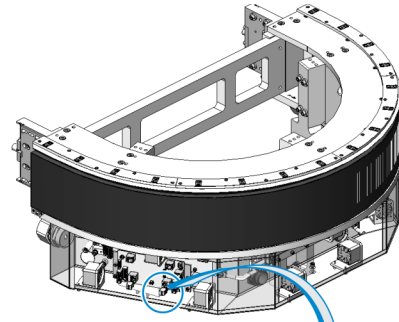

- For the 90 deg. section, the connection is located on the gateway board in the left electrical panel.

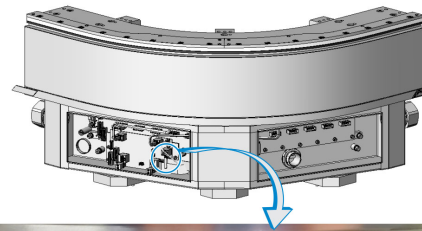

7. As applicable, connect the two (2) Ethernet cables (left and right network cables) to the F-F coupler:

- For the 180 deg. (500 mm) section, connect the cables on the right side (as indicated) of the F-F coupler.



- For the 180 deg. (800 mm) section, connect the cables to the left side (as indicated) of the F-F coupler.

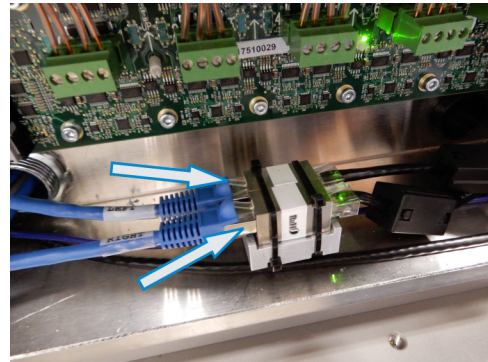

- For the 90 deg. section, connect the cables to the left side (as indicated) of the F-F coupler.

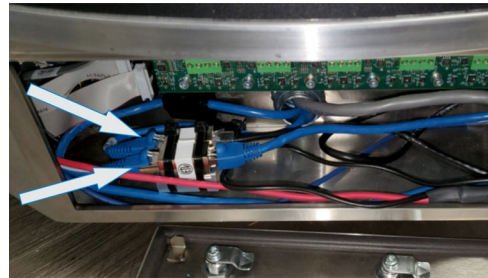

8. Install a ferrite onto the left network patch cable.

Make sure the ferrite is within 10 cm (4 in.) of the connector.

9. As applicable, connect the left network patch cable to the F-F coupler:

- For the 180 deg. (500 mm) section, connect the cable opposite from the left network cable.

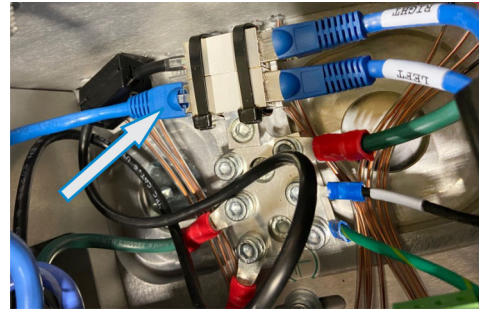

- For the 180 deg. (800 mm) section, connect the cable opposite from the left network cable.

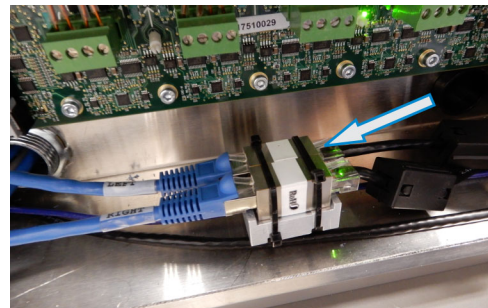

- For the 90 deg. section, connect the cable opposite from the left network cable (as indicated).

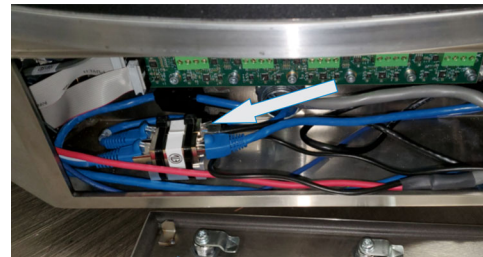

10. Verify that a ferrite exists on the end of each gateway network cable entering the 180 deg. section from the adjoining straight section.

Make sure each ferrite is within 10 cm (4 in.) of the connector.

11. As applicable, connect the gateway network cable from the adjoining straight section on the right to the F-F coupler:

- For the 180 deg. (500 mm) section, connect the cable opposite from the right network cable.

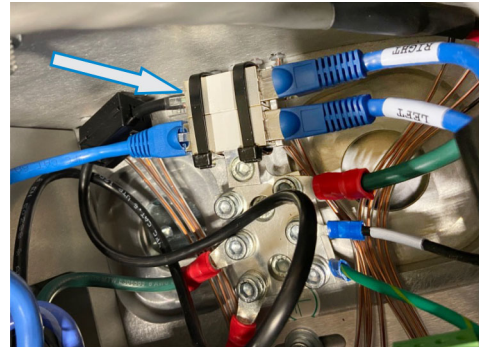

- For the 180 deg. (800 mm) section, connect the cable opposite from the right network cable.

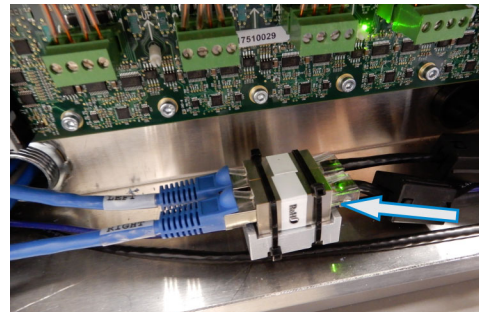

- For the 90 deg. section, connect the cable opposite from the right network cable.

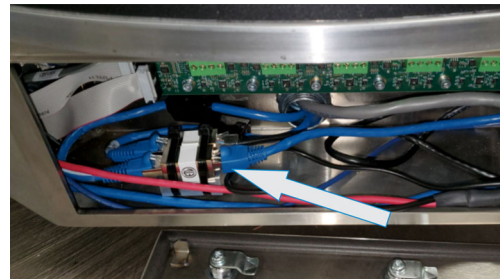

12. As applicable, connect the other end of the left network patch cable:

- For the 180 deg. (500 mm) section, connect the cable to the gateway board within the 180 deg. section.

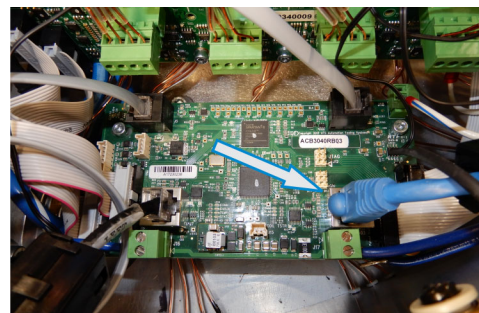



- For the 180 deg. (800 mm) section, connect the cable to the gateway board in the right electrical enclosure within the 180 deg. section.

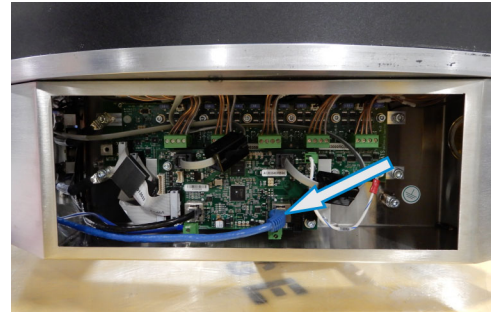

- For the 90 deg. section, connect the cable to the gateway board in the left electrical enclosure within the 90 deg. section.



13. Feed the five (5) cables of the interconnect cable through the plug opening at the back of the SuperTrak control panel.
14. Secure the end of the interconnect cable in the opening of the control panel using the supplied lock nut.
15. Install a ferrite on the end of the left and right network cables. Make sure each ferrite is within 10 cm (4 in.) of the connector.
16. Connect the other end of the left and right network cables to the controller in the SuperTrak control panel.

See [Left and Right Gateway Networks](#) on page 122.



17. Connect the common connection wire (COM) to -X2:211 in the SuperTrak control panel.

This is a black wire or a white wire with a blue stripe, depending on the system version.

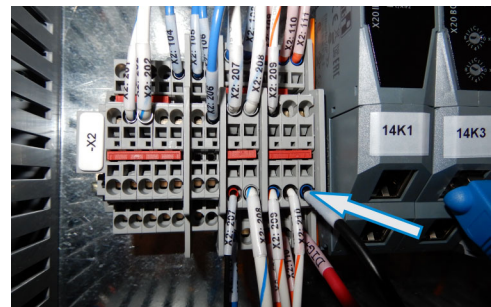

18. Connect the 24VDC digital power wire (DIG+) to -X2:111 in the SuperTrak control panel.

This is a red wire or blue wire, depending on the system version.

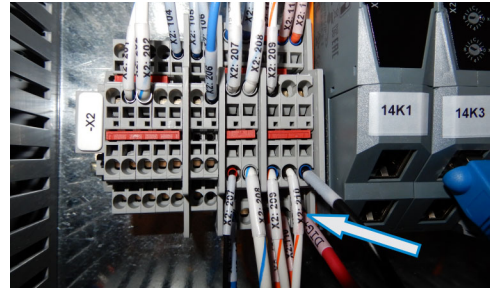

19. Connect the digital shield wire (GND) to -X1:112 in the SuperTrak control panel.

This is a black wire.

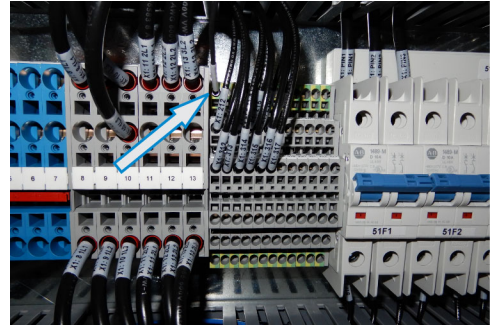

## Mechanical Procedures

**DANGER**

Always make sure the safety circuit is open (which turns OFF the SuperTrak conveyance platform motor power) when completing any mechanical procedures.

See *Hazardous Energy* on page 8.

Some equipment requires periodic adjustment to re-establish the accuracy and desired output of the SuperTrak conveyance platform. ATS recommends replacing defective devices rather than repairing them. Only qualified technicians should perform maintenance tasks.

### Install a Pallet

**CAUTION**

- The magnetic field generated by the pallet magnets can be harmful to pacemaker wearers. Maintain a minimum distance of 31 cm (12 in.) between the pallet and the implant location. The magnetic field may also induce magnetic materials into motion, creating potential projectiles or pinch points. Various electronic equipment and magnetic data carriers can also be affected by magnetic fields. Install a keeper plate on the pallet magnet to reduce the magnetic field to a safe level.
- Make sure the motor power is OFF when a pallet is installed on the SuperTrak conveyance platform. The external safety circuit must turn the failsafe output to the control panel OFF when the guard doors are open, to disable the motor power.

**NOTICE**

The magnetic attraction between the permanent magnets of the pallet and the motor increases as the distance decreases. Prevent strong impact of the pallet with the motor or damage can occur.

1. Open the safety circuit.
2. Slide the keeper plate off the pallet magnet assembly.

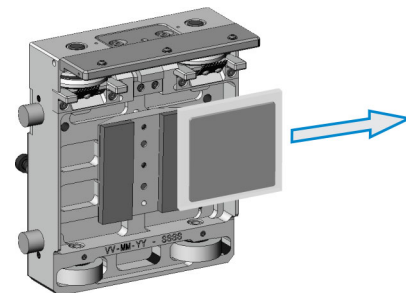

3. Install the pallet removal tool on the pallet:

- a. Align the pallet removal tool holes with the pallet shoulder screws and then position the tool against the front of the pallet.

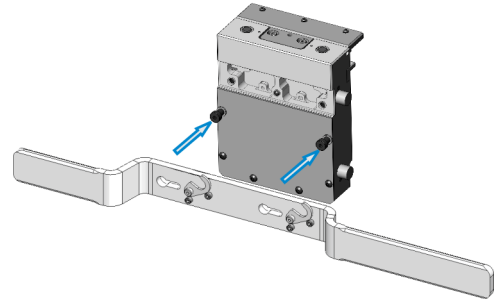

- b. Slide the pallet removal tool to the left, to locate the shaft of the two (2) shoulder screws into the tool slots.
- c. Rotate a locking finger over each of the two (2) shoulder screws.

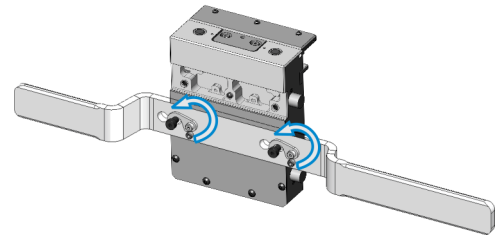

4. Lift the pallet using the handles of the pallet removal tool.

Make sure the encoder strip assembly is positioned at the top of the pallet.

5. Hold the pallet removal tool firmly. Rest the top left corner of the pallet on the upper v-rail of the SuperTrak conveyance platform, and then, align the anti-tip block of the pallet with the slot below the upper v-rail.

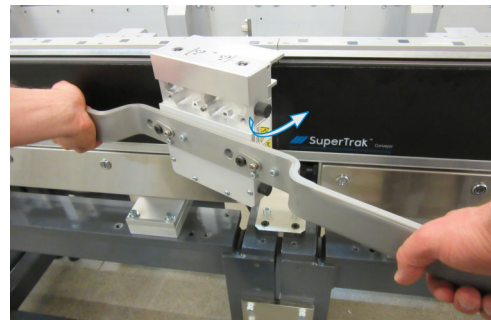

6. Hold the pallet level. With the anti-tip block in the left slot, rotate the pallet toward the motor until the anti-tip block on the right side moves into the slot below the upper v-rail.

Prevent strong impact of the pallet with the motor or damage could occur.

7. Remove the pallet removal tool from the pallet.
8. Verify that a 0.5 mm (0.02 in.) gap exists between the pallet encoder strip assembly and the encoder assembly.

See [Adjust a Pallet Shim](#) on page 207 for how to correctly measure or (if required) adjust the gap.

## Remove a Pallet

**CAUTION**

- The magnetic field generated by the pallet magnets can be harmful to pacemaker wearers. Maintain a minimum distance of 31 cm (12 in.) between the pallet and the implant location. The magnetic field may also induce magnetic materials into motion, creating potential projectiles or pinch points. Various electronic equipment and magnetic data carriers can also be affected by magnetic fields.
- Always install a keeper plate on the pallet magnet when a pallet is removed from the SuperTrak conveyance platform to reduce the magnetic field to a safe level.
- Make sure the motor power is OFF when a pallet is installed on the SuperTrak conveyance platform. The external safety circuit must turn the failsafe output to the control panel OFF when the guard doors are open, to disable the motor power.

**NOTICE**

The magnetic attraction between the permanent magnets of the pallet and the motor increases as the distance decreases. Prevent strong impact of the pallet with the motor or damage can occur.

1. Open the safety circuit.
2. Install the pallet removal tool on the pallet:
  - a. Align the pallet removal tool holes with the pallet shoulder screws and then position the tool against the front of the pallet.

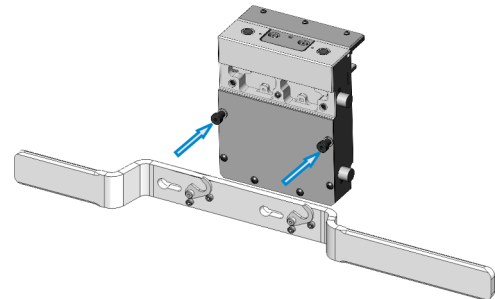

- b. Slide the pallet removal tool to the left, to locate the shaft of the two (2) shoulder screws into the tool slots.
- c. Rotate a locking finger over each of the two (2) shoulder screws.

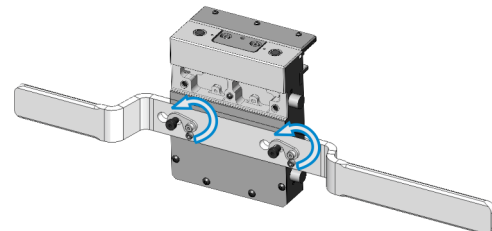

3. Pry or tilt the pallet away from the motor: firmly hold both pallet removal tool handles, and then pull the right handle while resisting with the left handle

At approximately 15 degrees the magnetic pull decreases and the pallet can be removed from the motor.

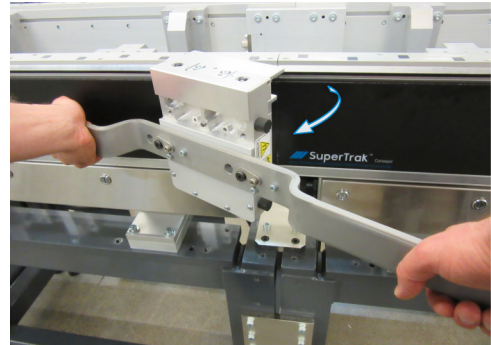

4. Slide a keeper plate over the pallet magnet assembly with the polycarbonate side of the keeper plate against the pallet magnet.

The keeper plate reduces the magnetic field produced by the magnet. The lexan creates a gap between the magnets and the steel plate. Hold the keeper plate in a manner that avoids fingers getting caught between the keeper plate and the magnets.

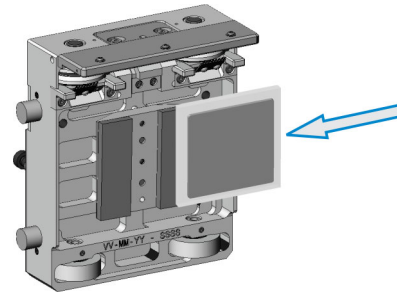

## Inspect a Pallet

**NOTICE**

Handle pallets carefully to avoid damage to the pallet components.

Inspect pallets for wear on a regular basis and each time a pallet is removed from the SuperTrak conveyance platform. Inspect the pallet:

Pallet Component	Inspection	Resolution
Anti-static brush	<p>Verify that the two (2) screws that secure the anti-static brush are tight.</p> <p>The nominal length of a new anti-static brush is 4.05 mm (0.159 in.). When 0.5 mm (0.02 in.) of the anti-static brush is worn away, it will not make contact with the upper v-rail.</p> <p>Visually inspect the anti-static brush. Make sure that at least 90% of the bristles remain. If more than 20% of the bristles are worn away, replace the anti-static brush.</p>	<p>Tighten any loose anti-static brush screws.</p> <p>Replace the anti-static brush. See <a href="#">Replace a Pallet Anti-Static Brush</a> on page 206.</p>
Bumpers	<p>Verify that all bumpers are installed and compliant with the SuperTrak conveyance platform application. If required, install or adjust the bumpers. See the main system mechanical drawings for compliance information. For example, the bumpers may require extensions.</p>	<p>Replace the pallet bumper. See <a href="#">Replace a Pallet Bumper</a> on page 198.</p>
Pallet encoder strip assembly	<p>Visually inspect the encoder strip assembly and the encoder assembly for damage. Use a magnetic viewing film to verify the magnetic poles.</p>	<p>If required, replace the encoder assembly. See <a href="#">Replace an Encoder Assembly</a> on page 165, and <a href="#">Inspect a Pallet Encoder Strip</a> on page 248.</p>
Screws	<p>Verify that all pallet screws are secure. Make sure components do not have unexpected movement. The only components that should have movement are: v-wheels, spring-compliance of the lubrication Felt, anti-static bristles, and a small amount of vertical movement in the flat wheels (<math>\leq 0.5</math> mm [<math>\leq 0.02</math> in.]).</p>	<p>If required, tighten the screws.</p>

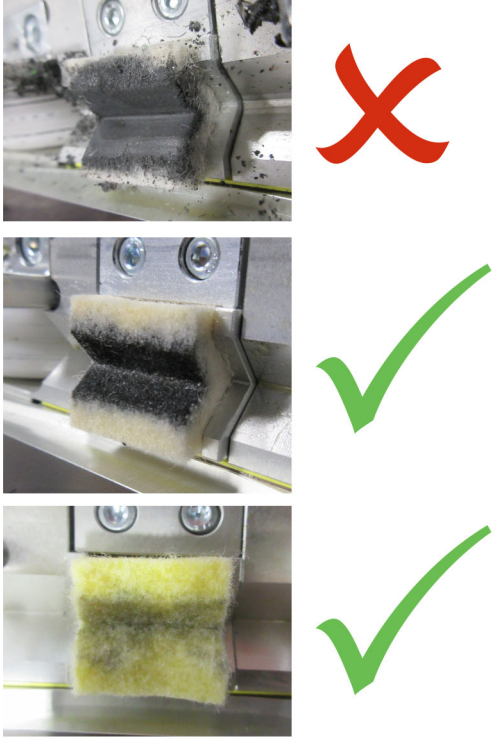
Pallet Component	Inspection	Resolution
Lubrication felt	<p>Visually inspect the lubrication felt. Make sure the felt is in good condition.</p> 	<p>If required, replace the lubrication felt. See <a href="#">Replace a Pallet Lubrication Felt</a> on page 210.</p>
	<p>Verify that the lubrication felt contains lubricant. If debris accumulates on the upper v-rail, it is possible that all lubrication felts require lubricant.</p>	<p>Lubricate the lubrication felt. See <a href="#">Lubricate the Pallet Lubrication Felt</a> on page 250.</p>
	<p>Test the lubrication felt spring compliance. Manually push the lubrication felt and then let go. The lubrication felt spring should spring back out and not jam.</p>	<p>If the lubrication felt spring jams, loosen the lubrication locking block screws, re-seat the lubrication locking block, and tighten the screws. If the lubrication felt spring does not spring back reliably, replace the lubrication felt spring. See <a href="#">Replace a Pallet Spring</a> on page 211.</p>



Pallet Component	Inspection	Resolution
Magnet assembly	Visually inspect the magnet assembly for damage or wear (for example; cracks or flaking magnet plating).	Replace the pallet magnet assembly. See <a href="#">Replace a Pallet Magnet Assembly</a> on page 205.
	Visually inspect the magnet assembly for dirt or debris.	Clean dirt and debris off of the magnet assembly, using a clean, soft cloth. Wipe metal debris to a corner or edge of the magnet and then pull it off.
Wheels	<ul style="list-style-type: none"> <li>• Check each flat wheel for vertical and horizontal movement. A small amount of vertical play (<math>\leq 0.5</math> mm [<math>\leq 0.02</math> in.]) in the flat wheels is normal and acceptable. If a flat wheel does not sit firmly in position, replace the flat wheel and make sure that the spacers are present.</li> <li>• Check each v-wheel for vertical movement. If the v-wheel does not sit firmly in position, tighten the screw at the top of the v-wheel.</li> </ul>	See <a href="#">Replace the Pallet Flat Wheels</a> on page 199, and <a href="#">Replace the Pallet V-Wheels</a> on page 201.
	Turn each wheel to make sure it moves freely. Replace any wheels that do not move freely.	
	Visually inspect each flat wheel for wear or damage. Replace any badly damaged wheels. If a wheel has a groove worn into it, this may indicate that the flat wear strips, located on the straight section or curved section, are pitted. The flat wear strip may require replacement. Visually inspect v-wheels. If a wheel is damaged, make sure the upper v-rail is not damaged and that it is correctly aligned.	See <a href="#">Replace a Flat Wear Strip</a> on page 238, <a href="#">Replace the Pallet V-Wheels</a> on page 201, and <a href="#">Replace an Upper V-Rail</a> on page 230.

## Replace a Pallet Bumper

1. Remove the pallet from the SuperTrak conveyance platform.  
See [Remove a Pallet](#) on page 193.
2. Turn the bumper counter-clockwise and remove the bumper.

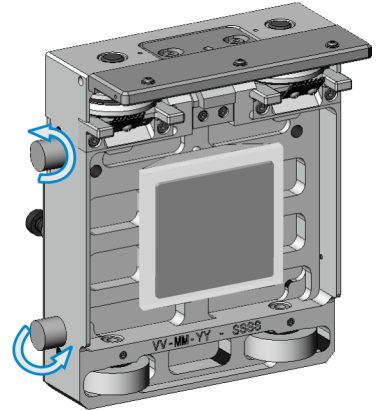

3. Align the replacement bumper threads with the bumper spacer (if used) or with the bumper hole on the pallet.

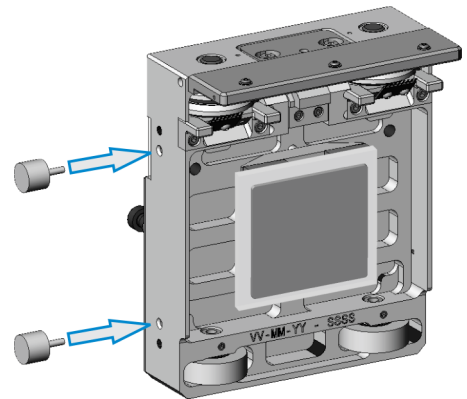

4. Turn the bumper clockwise until it is snug against the pallet.

## Replace the Pallet Flat Wheels

Inspect the flat wheels and spacers. Replace the flat wheels if they are worn (vertical play exceeds 0.5 mm [0.02 in.]) or damaged.

See *Typical Pallet Wheel Lifespan* on page 304 for additional information.

### Remove the Pallet Flat Wheels

1. Remove the pallet from the SuperTrak conveyance platform.  
See *Remove a Pallet* on page 193.
2. Loosen the two (2) wheel set screws.  
For ease of disassembly, rest the pallet on the shoulder screws or on the pallet encoder strip assembly.
3. Attempt to manually push the shaft out. If snug, thread a dowel puller into the shaft and pull the shaft out.  
If the shaft does not come out, loosen the set screw more.
4. Repeat step 3 for the second shaft.
5. Remove the flat wheels and two (2) spacers for each flat wheel.

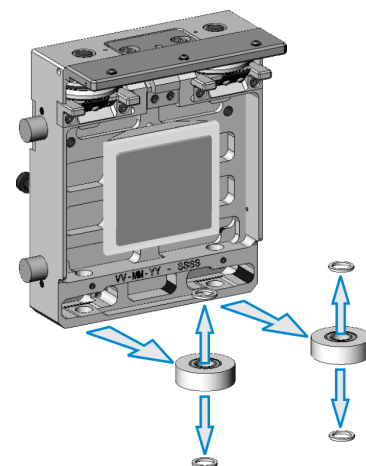
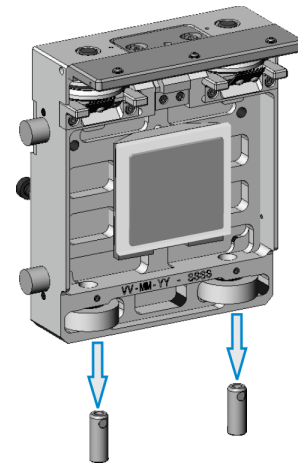
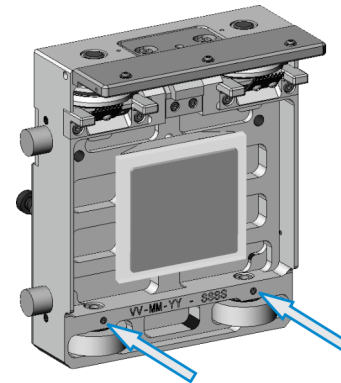

### Install the Pallet Flat Wheels

1. Hold a spacer on each side of the bearing of the new flat wheel and insert the flat wheel into the pallet body.

For ease of assembly, rest the pallet on the shoulder screws or upside down on the encoder strip assembly.

2. Align the spacer and flat wheel with the hole in the pallet body.

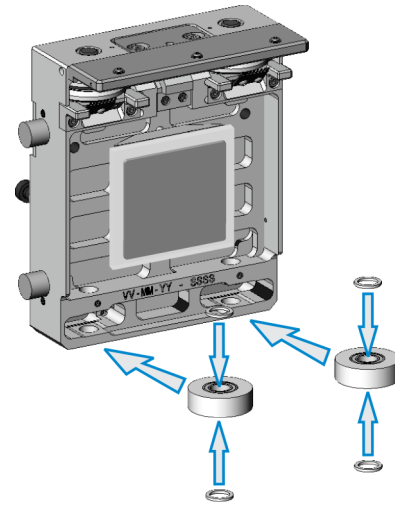

3. Position a dowel over the pallet body hole with the flat side of the shaft facing the set screw.

4. Attempt to manually push the shaft in.

If tight, use a mallet to gently tap the shaft until the top of the shaft is flush with the pallet body.

5. Repeat steps 1 to 4 for the second flat wheel.

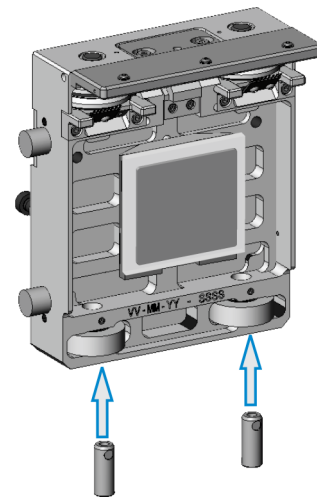

6. Fully remove the set screws, to verify that the flat of the shaft is aligned with the set screw.

If the set screw contacts the round of the shaft, it can score the shaft and make it difficult to remove the shaft later.

7. Install and tighten the two (2) wheel set screws.

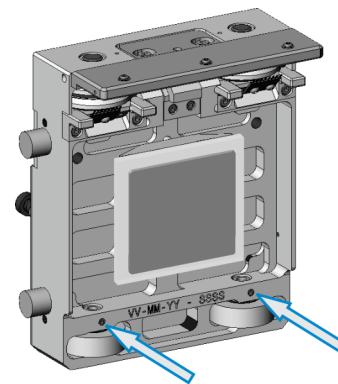

## Replace the Pallet V-Wheels



It is recommended to replace the pallet v-wheels in pairs.

Inspect the v-wheels for gouges, pits, or wear; replace if they are worn or damaged.

Pallet v-wheel wear varies depending on the system application. It is recommended that you verify the accuracy of critical pallet features over time, as required by the application. This allows you to compare the measurements to your process limits and recognize when replacement is necessary.

See *Typical Pallet Wheel Lifespan* on page 304 for additional information.

### Remove the Pallet V-Wheels

1. Remove the pallet from the SuperTrak conveyance platform.

See *Remove a Pallet* on page 193.

2. Remove the two (2) screws that secure the anti-tip block in position.
3. Remove the anti-tip block.
4. Repeat steps 2 to 3 for the second anti-tip block.

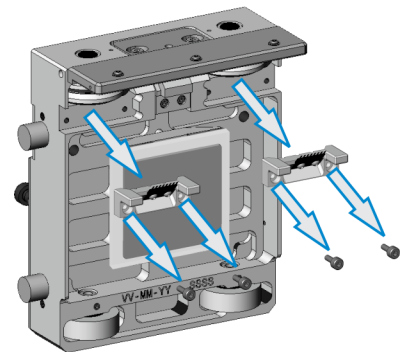

5. Remove the two (2) plastic caps on the top of the pallet.

For ease of disassembly, rest the pallet on the shoulder screws or on the encoder strip assembly.

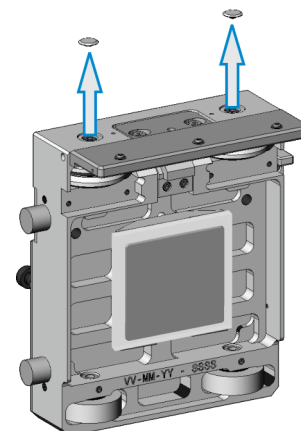

6. Remove the screw and washer that secures the v-wheel in position.
7. Repeat step 6 for the second v-wheel.

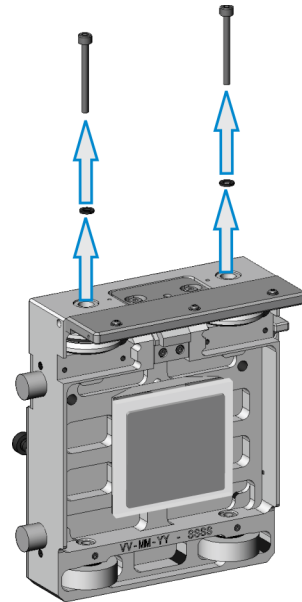

8. Attempt to manually pull the v-wheel shaft out. If snug, thread a dowel puller into the shaft and pull the shaft out.
9. Repeat step 5 for the second shaft.

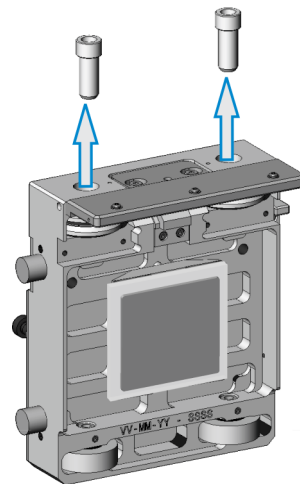

10. Remove the v-wheel and the spacer that is on the bottom of the v-wheel.  
Place the spacer in a safe location.

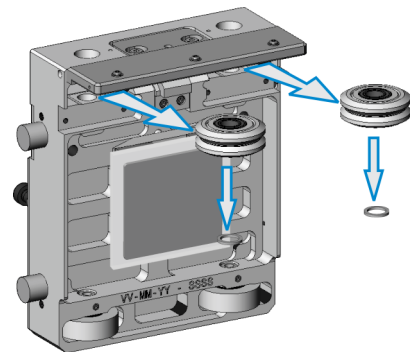

### Install the Pallet V-Wheels

1. Hold the new v-wheel so that the side with the groove is facing up.
2. Hold a spacer on the bottom of the new v-wheel and insert them into the pallet body.

For ease of assembly, rest the pallet on the shoulder screws or upside down on the encoder strip assembly.

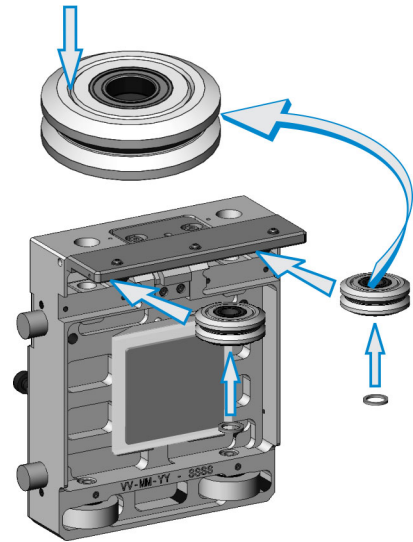

3. Align the spacer and v-wheel holes with the holes in the pallet body.
4. Manually insert the shaft through the v-wheel and spacer.

If tight, use a mallet to gently tap the shaft until the top of the shaft is flush with the pallet body.

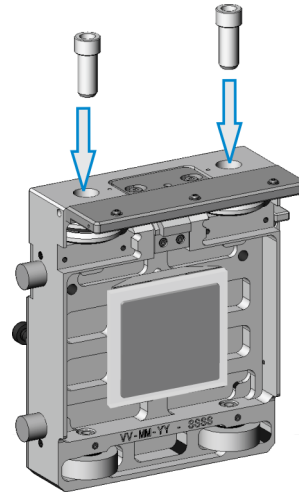

5. Repeat steps 1 to 4 for the second v-wheel.

6. Install a washer and screw into each of the two (2) v-wheel shafts, and then tighten.

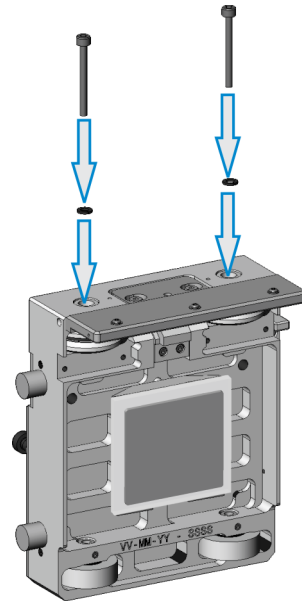

7. Install a plastic cap over each of the two (2) screws.

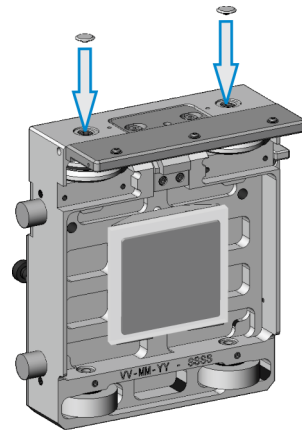

8. Install an anti-tip block in position, and then secure it in position with two (2) screws.

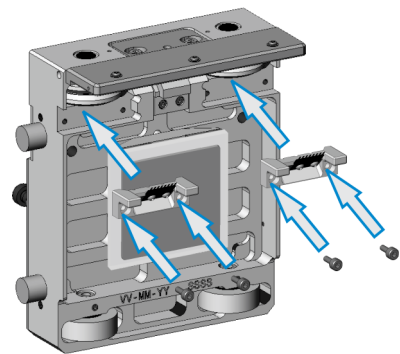

9. Repeat step 8 for the second anti-tip block.



## Replace a Pallet Magnet Assembly

1. Remove the pallet from the SuperTrak conveyance platform.  
See [Remove a Pallet](#) on page 193.
2. Remove the four (4) screws and two (2) shoulder bolts from the front cover plate.

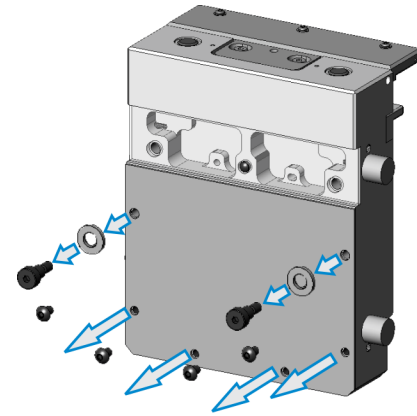

3. Remove the front cover plate from the pallet.

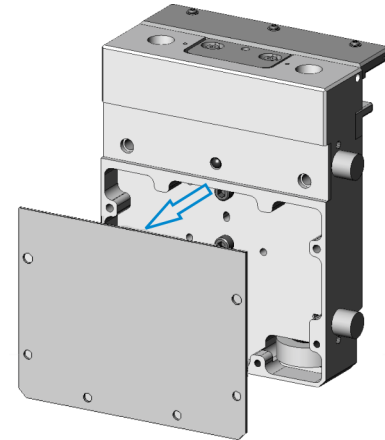

4. While supporting the magnet assembly, remove the two (2) or four (4) magnet assembly screws (as required).
5. Align the new magnet assembly (2-magnet or 3-magnet, as required) with the pallet dowel holes.

The magnet assembly can only be installed in one direction: it cannot be assembled upside down.

6. As required, secure the 2-magnet assembly in position with two (2) screws, or the 3-magnet assembly with four (4) screws.
7. Align the front cover plate with the pallet.
8. Secure the front cover plate in position with four (4) screws and two (2) shoulder bolts.

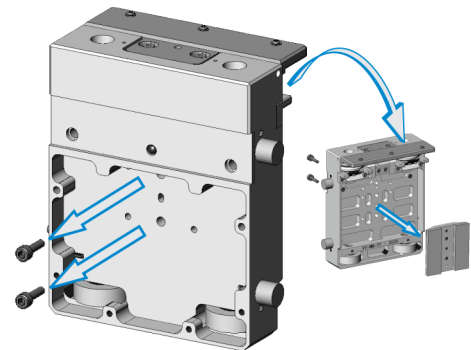

## Replace a Pallet Anti-Static Brush

**NOTICE**

The anti-static bristles can be bent out of shape if mishandled. Take care not to damage the anti-static bristles during this procedure.

The nominal length of a new anti-static brush is 4.05 mm (0.159 in.). When 0.5 mm (0.02 in.) of the anti-static brush is worn away, it will not make contact with the upper v-rail. Replace an anti-static brush if more than 20% of the brush bristles are worn away.

### Remove an Anti-Static Brush

1. Remove the pallet from the SuperTrak conveyance platform.  
See [Remove a Pallet](#) on page 193.
2. Remove the two (2) screws that secure the anti-static brush in position.
3. Remove the anti-static brush.

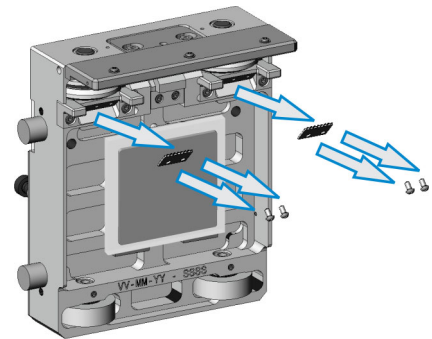

### Install an Anti-Static Brush

1. Align the new anti-static brush with the outer holes of the anti-tip block.  
Make sure the bristles of the anti-static brush face up, toward the V-wheel.
2. Install two (2) screws to secure the anti-static brush in position.

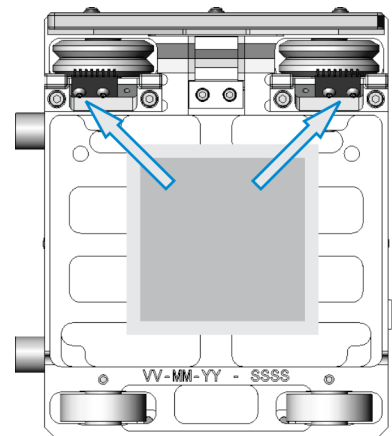

## Adjust a Pallet Shim

The pallet shim is factory-set to obtain a 0.5 mm (0.02 in.) gap between the pallet encoder assembly and the SuperTrak conveyance platform encoder assembly. Adjust the pallet shim if the gap is outside of the range of 0.5 mm (0.02 in.) +/- 0.3 mm (0.01 in.).

1. With the pallet installed, measure the gap between the pallet encoder strip assembly and the SuperTrak conveyance platform:
  - a. Place a 0.5 mm (0.02 in.) plastic shim on the aluminum surface of the encoder assembly. Do not place the shim over a pallet encoder strip assembly.

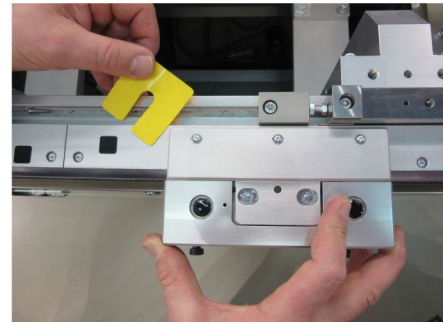
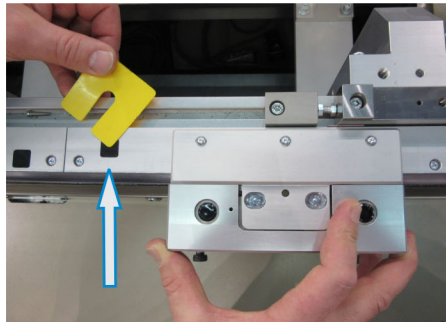

- b. Slide the pallet over the shim.
- c. Use different size shims to determine if the gap is greater or less than 0.5 mm (0.02 in.), and by how much.

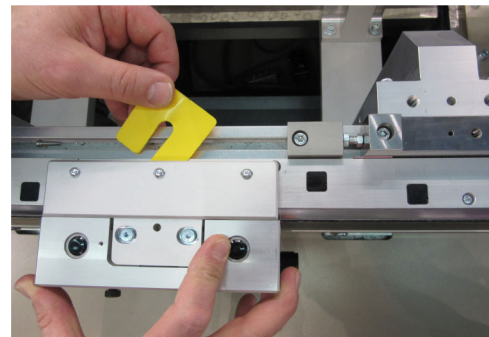

2. If the gap is greater than 0.5 mm (0.02 in.) +/- 0.3 mm (0.01 in.), verify that the pallet shim is the problem (not the v-wheels or pallet encoder strip assembly):
  - Make sure that the v-wheels are secure with no vertical play. If the v-wheels have vertical movement; secure the v-wheels in position, and then re-measure the encoder strip gap.
  - Make sure that the encoder strip assembly is secure and flush with the encoder assembly. If required; replace the encoder strip assembly, and then re-measure the encoder strip assembly gap.

See [Replace a Pallet Encoder Strip Assembly](#) on page 212.

3. Remove the two (2) outer set screws, located on the side of the pallet.
4. Loosen the two (2) inner set screws, located on the side of the pallet.
5. Remove the two (2) screws, two (2) lock washers, and two (2) flat washers that secure the pallet encoder strip assembly in position.

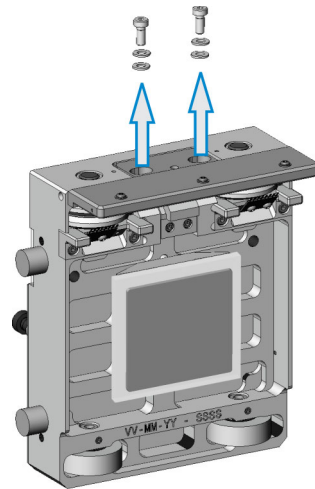

6. Lift and remove the pallet encoder strip assembly.

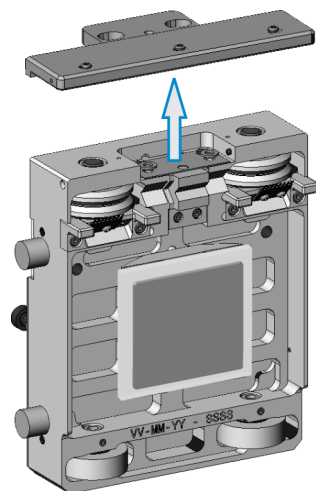

7. Lift and remove the pallet shim.

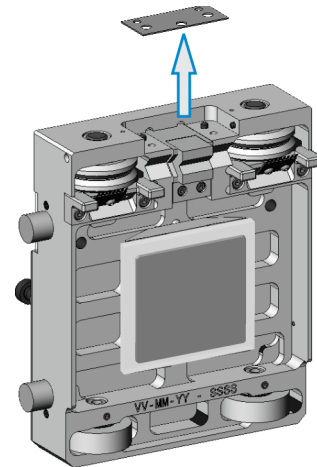

8. Measure the current combined shim thickness.
9. Use shims to adjust the gap to 0.5 mm (0.02 in.).  
Shims are available in a range of sizes from ATS.
10. Align the new pallet shim with the pallet dowels, and then place in position.  
The shim can only be installed one way.
11. Position the pallet encoder strip assembly in position.
12. Secure the pallet encoder strip assembly in position with one (1) flat washer, one (1) lock washer, and one (1) screw in each of the two (2) screw holes.
13. Repeat step 1.
14. Align the pallet encoder strip assembly.

See [Adjust the Pallet Encoder Strip Assembly \(Primary Encoder Strip\)](#) on page 226.

## Replace a Pallet Lubrication Felt

1. Remove the pallet from the SuperTrak conveyance platform.  
See [Remove a Pallet](#) on page 193.
2. Remove the two (2) lubrication locking block screws.

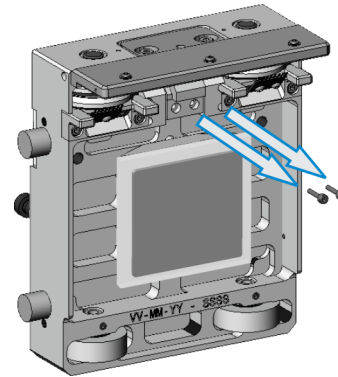

3. Remove the lubrication locking block.

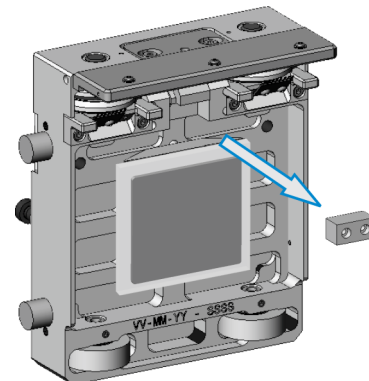

4. Remove the lubrication holder.

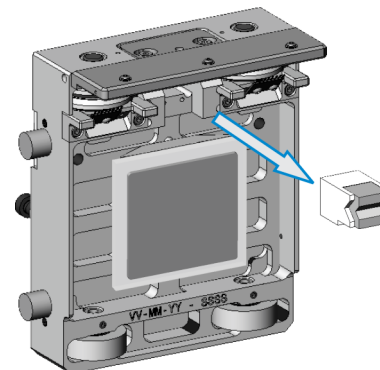

5. Remove the screw from the back of the lubrication holder, and then remove the lubrication felt from the lubrication holder.

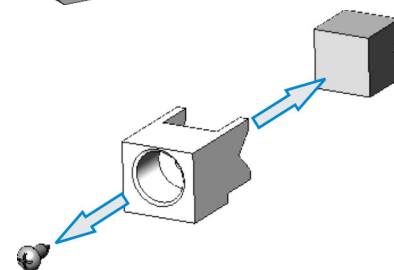

6. Position a new lubrication felt into the lubrication holder.  
Make sure the V-groove of the lubrication felt aligns with the V-groove of the lubrication holder.
7. Install one (1) screw in the back of the lubrication holder and into the lubrication felt.
8. Insert the lubrication holder into the pallet.  
Make sure the V-groove of the lubrication Felt is horizontal with the pallet V-wheels.
9. Install the lubrication locking block over the base of the lubrication holder.
10. Secure the lubrication locking block in position with two (2) screws.
11. Lubricate the lubrication felt.

See [Lubricate the Pallet Lubrication Felt](#) on page 250.

## Replace a Pallet Spring

1. Complete steps 1 to 4 of [Replace a Pallet Lubrication Felt](#) on page 210.
2. Remove the spring.

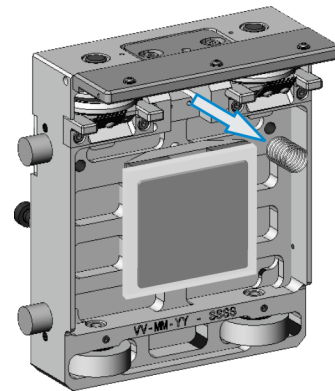

3. Position a new spring into the pallet.
4. Complete steps 6 to 10 of [Replace a Pallet Lubrication Felt](#) on page 210.

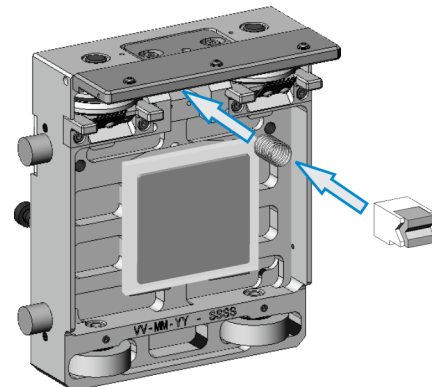

## Replace a Pallet Encoder Strip Assembly

**NOTICE**

Pallet encoder strips can be damaged by magnets. Never clean a pallet encoder strip with a magnet.

1. Remove the pallet from the SuperTrak conveyance platform.

See [Remove a Pallet](#) on page 193.

2. Loosen the two (2) set screws on the side of the pallet.

There is one set screw on each side of the pallet.

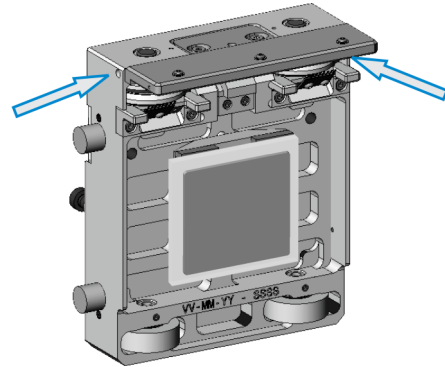

3. Remove the two (2) screws, two (2) lock washers, and two (2) flat washers that secure the pallet encoder strip assembly in position.

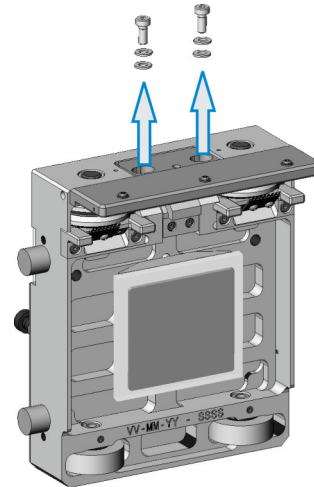



4. Lift and remove the pallet encoder strip assembly.

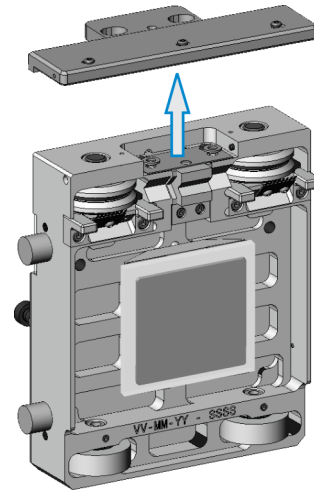

5. Obtain a replacement encoder assembly with a new encoder strip mounted. Order this part from ATS.
6. Align the pallet encoder strip assembly that has a new encoder strip with the pallet.
7. Secure the pallet encoder strip assembly in position with two (2) screws, two (2) lock washers, and two (2) flat washers.
8. Align the pallet encoder strip assembly.  
See [Adjust the Pallet Encoder Strip Assembly \(Primary Encoder Strip\)](#) on page 226.
9. Install the pallet on the SuperTrak.  
See [Install a Pallet](#) on page 191.
10. Verify that a 0.5 mm (0.02 in.) +/- 0.3 mm (0.01 in.) gap exists between the pallet encoder strip assembly and the encoder assembly.  
If the gap is less than 0.5 mm (0.02 in.) +/- 0.3 mm (0.01 in.), see [Adjust a Pallet Shim](#) on page 207.

## Install a Station Setup Fixture

**NOTICE**

- Improper use of a station setup fixture may cause damage to the pallets or tools.
- Do not move or adjust a station setup fixture without the assistance of a trained technician.
- Remove all removable locating plates before operating the SuperTrak conveyance platform.

Install a station setup fixture when station tooling alignment verification is required.

<b>A</b>	Station setup stationary mount
<b>B</b>	Top thumb screw (1 of 2)
<b>C</b>	Station setup removable locate
<b>D</b>	Side thumb screw

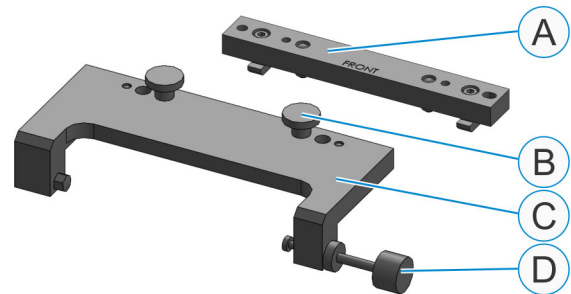

1. Position a pallet below a station setup stationary mount.
2. Place the station setup removable locate over the pallet.
3. Tighten the two (2) top thumb screws to secure the station setup removable locate to the station setup stationary mount.
4. Lightly tighten the side thumb screw to lock the pallet in position against the datum. The side thumb screw has an integrated slip clutch to prevent over-tightening.

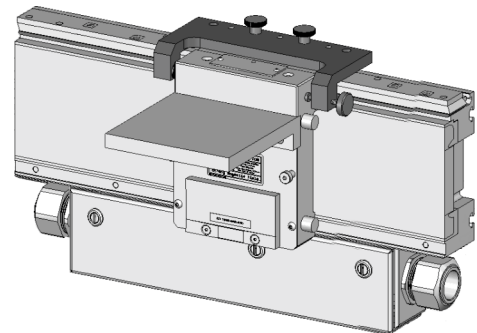

## Remove a Station Setup Fixture

1. Loosen the side thumb screw.
2. Loosen the two (2) top thumb screws.
3. Lift the station setup removable locate straight up, to remove it from the pallet.
4. As required, complete one of the following procedures:
  - Store the station setup removable locate in a safe place for future use.
  - Turn the station setup removable locate around, so the side thumb screw is on the inside of the SuperTrak conveyance platform, and then tighten the two (2) top thumb screws to secure it in position for future use.

## Align a Pallet Encoder Strip Assembly

**NOTICE**

- Improper use of a pallet setup fixture may cause damage to the pallets or tools.
- Do not move or adjust a pallet setup fixture without the assistance of a trained technician.
- Remove all removable locating plates before operating the SuperTrak conveyance platform.



- Pallet encoder strip assembly alignment must be completed on a straight section.
- Adjust pallet encoder strips consistently to improve pallet-to-pallet repeatability.

Each pallet encoder assembly contains two (2) encoder strips: a primary encoder strip, and a secondary encoder strip. Each encoder strip is aligned differently. This procedure describes how to align both encoder strips; however, the secondary encoder strip is factory-aligned, and should not require adjustment.

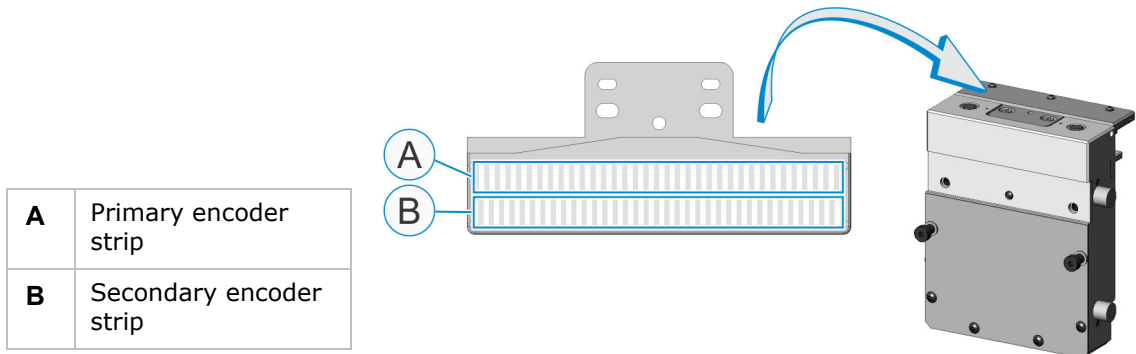

Align a pallet encoder strip assembly if the encoder strip is removed during maintenance, or if the pallet position faults regularly occur on the curved section.

The following diagram describes the setup tools that are used during this procedure.

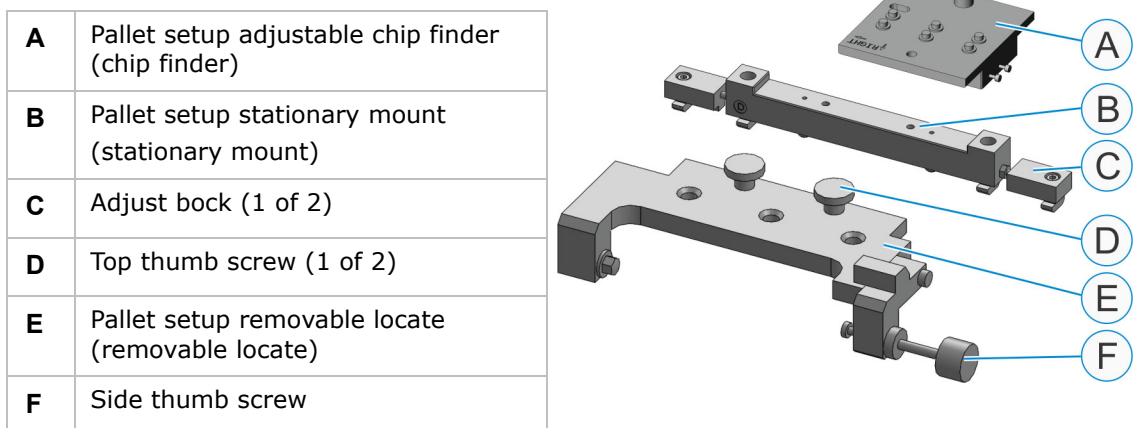

1. Install a pallet setup stationary mount on a straight section.  
See [Install a Pallet Setup Stationary Mount](#) on page 217.
2. Optionally, for systems that require tight tolerances, verify that the pallet setup stationary mount is parallel with the upper-v-rail.  
See [Verify Pallet Setup Stationary Mount Parallelism](#) on page 218.
3. Center the pallet setup stationary mount with an encoder on the straight section encoder assembly.  
See [Center a Pallet Setup Stationary Mount with an Encoder](#) on page 219.
4. Verify that the pallet setup stationary mount is in the correct position.  
See [Verify the Pallet Setup Stationary Mount Position](#) on page 223.  
The pallet setup stationary mount is now centered with an encoder on the straight section.
5. Determine the distance between two encoders.  
See [Reference the Encoder Position](#) on page 225.
6. If required, center the encoder assembly with the center of the pallet.  
See [Adjust the Pallet Encoder Strip Assembly \(Primary Encoder Strip\)](#) on page 226.
7. If required, align the secondary encoder strip with the primary encoder strip.  
See [Adjust a Secondary Encoder Strip](#) on page 227.

## Install a Pallet Setup Stationary Mount

1. Position a stationary mount on a straight section. Make sure the datum surface, which is etched with the a "D", faces toward the encoders. Roughly center the stationary mount with an odd-numbered encoder.

In the example below, all odd-numbered encoders are circled. The stationary mount is aligned with encoder 3 (the 4<sup>th</sup> encoder from the left).

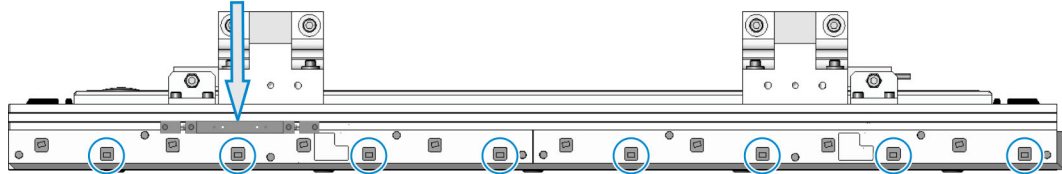

2. Install shims between the encoder assembly and the stationary mount, to bias the stationary mount to the back of the t-slot.

In the example on the right, a green and white 0.729 mm (0.028 in.) shim is installed on the left, and a white 0.653 mm (0.025 in.) shim is installed on the right to bias the stationary mount to the back.

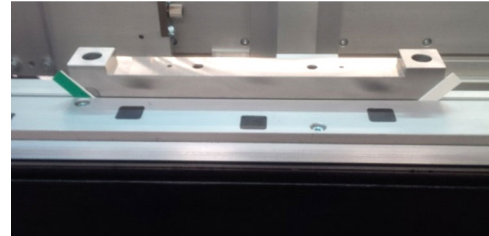

3. Lower the shims all the way down.

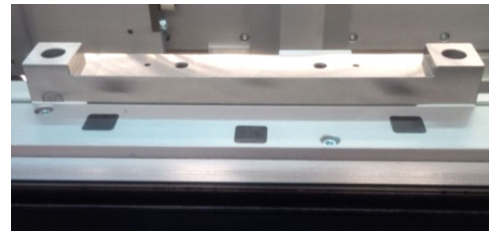

4. Snug the two (2) stationary mount screws.

Make sure the t-nuts turn and lock into the t-slots.

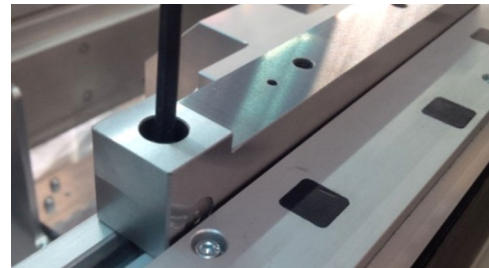

5. Position an adjust block at the end of the stationary mount, and secure it in position with one (1) screw.

6. Repeat step 5 at the other end of the stationary mount.

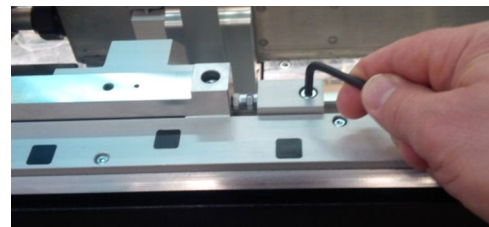

## Verify Pallet Setup Stationary Mount Parallelism



This procedure is optional. It is okay if the nominal for a particular system is slightly off from true nominal (for example; off by 10-20  $\mu\text{m}$ ). The important thing is that all pallets on the SuperTrak system are adjusted to the same nominal.

This procedure is optional. It describes how to verify stationary mount parallelism. If a stationary mount is parallel with the upper v-rail, the system nominal is slightly closer to true nominal.

1. Install a stationary mount.

See [Install a Pallet Setup Stationary Mount](#) on page 217.

2. Mount a dial indicator on a pallet, such that it contacts the datum face of the stationary mount.

For example; mount a dial indicator to the top or side of a pallet with a rigid clamp.

3. Note the dial indicator measurements as you slowly slide the pallet, from left to right, along the stationary mount.
4. Based on the dial indicator results, complete one (1) of the following:

- If the dial indicator measurements are the same on each side of the stationary mount, the face of the stationary mount is parallel with the upper v-rail. The procedure is complete.

For example:

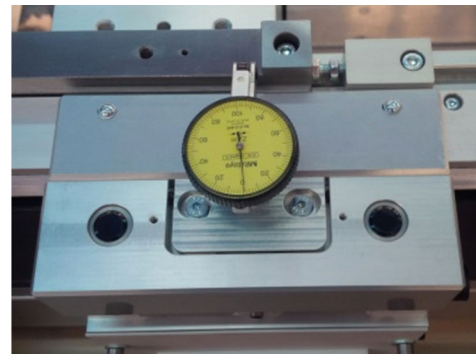
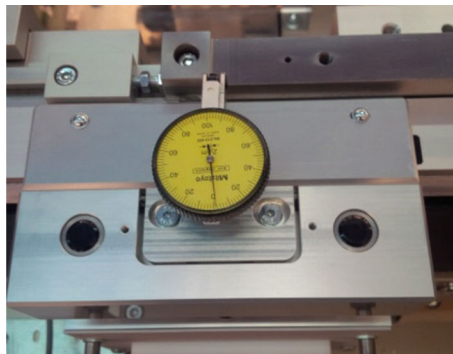

- If the value on the dial indicator is different on each side of the pallet setup stationary location, the face of the stationary mount is not parallel with the upper v-rail. Proceed to step 4.
5. Replace the shims, installed in step 1, with shims that are the correct size to improve parallelism.
  6. Repeat steps 2 to 3.

## Center a Pallet Setup Stationary Mount with an Encoder

1. If required, install a stationary mount.  
See *Install a Pallet Setup Stationary Mount* on page 217.
2. Install the chip finder on the left side of the stationary mount:
  - a. Align the chip finder with the left side of the stationary mount.
  - b. Loosely secure the chip finder in position using the thumb screw.
  - c. Firmly hold the chip finder back and to the left (corner crowd), and then tighten the thumb screw.

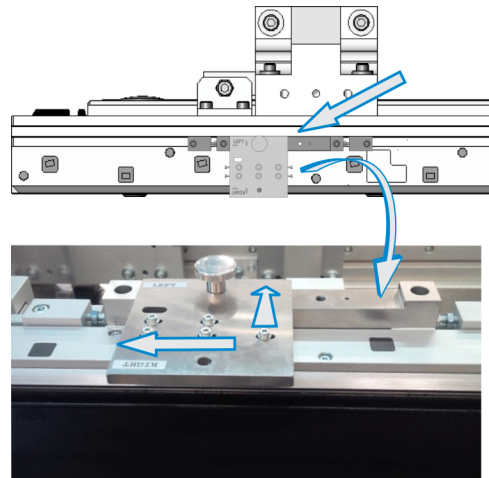

3. In the TrakMaster software, expand **Diagnostics**, and then click **Encoders**.
4. Click the **Fixture Setup** tab.
5. Click the encoder that the stationary mount is aligned with.  
For example; if the stationary mount was installed at encoder 3, "3" would be selected.

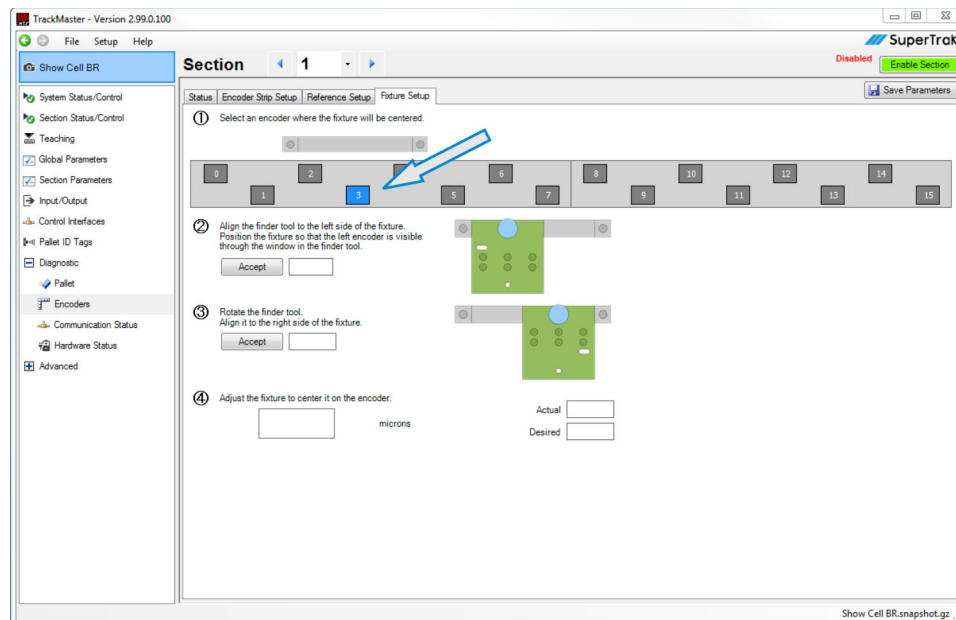

6. For step 2 on the TrakMaster screen, click **Accept**.

7. Remove the chip finder from the left side of the stationary mount and turn it 180°.
8. Install the chip finder on the right side of the stationary mount:

- a. Align the chip finder with the left side of the stationary mount.
- b. Loosely secure the chip finder in position using the thumb screw.
- c. Firmly hold the chip finder back and to the left, and then tighten the thumb screw.

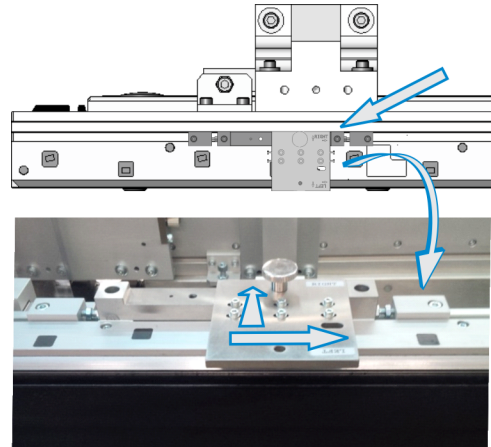

9. For step 3 on the TrakMaster screen, click **Accept**.
10. View the value displayed in step 4 on the TrakMaster screen to determine the direction and distance to adjust the pallet setup station locate.

For example; this screen indicates that the pallet setup station locate must be adjusted to the left 158 microns.

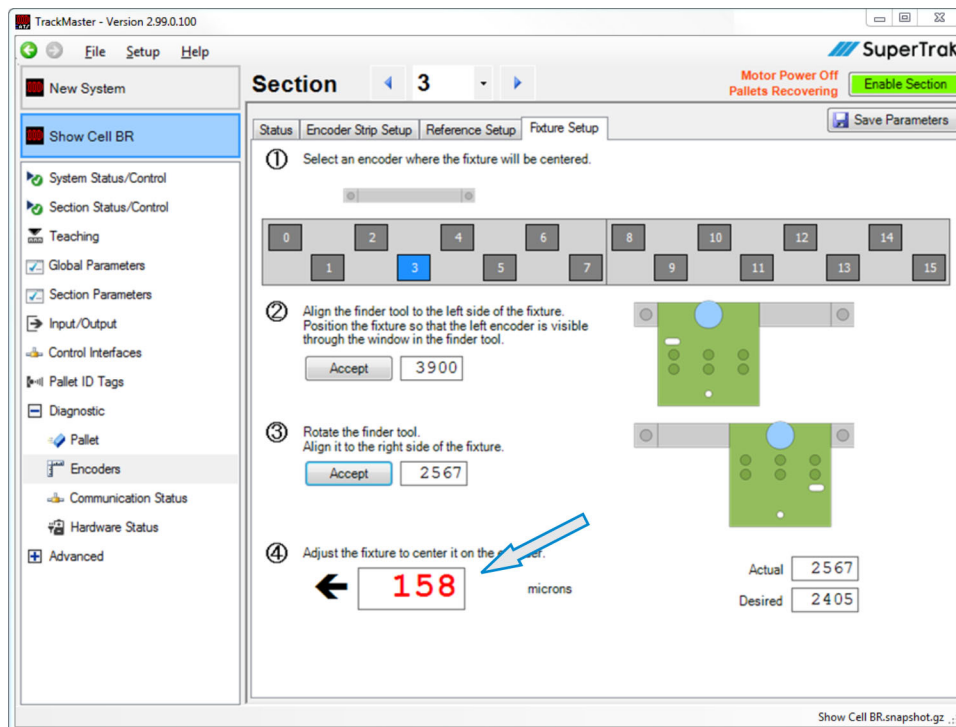



11. As required, adjust the position of the pallet setup station locate:

- a. Slightly loosen the two (2) stationary mount screws.
- b. Use a wrench to loosen the lock nut.
- c. Use a wrench to turn the hex head bolts as required to fine-adjust the position of the pallet setup station locate.

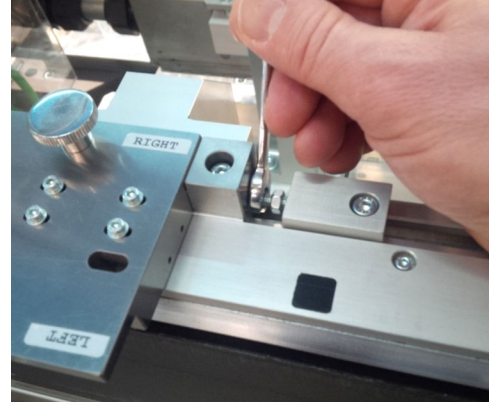

12. Click the first **Accept** button again, to restart the process.

13. Repeat steps 3 to 12, until the pallet setup station locate position is  $\pm 2$  microns.

In the example below, the pallet setup station locate is precisely centered.

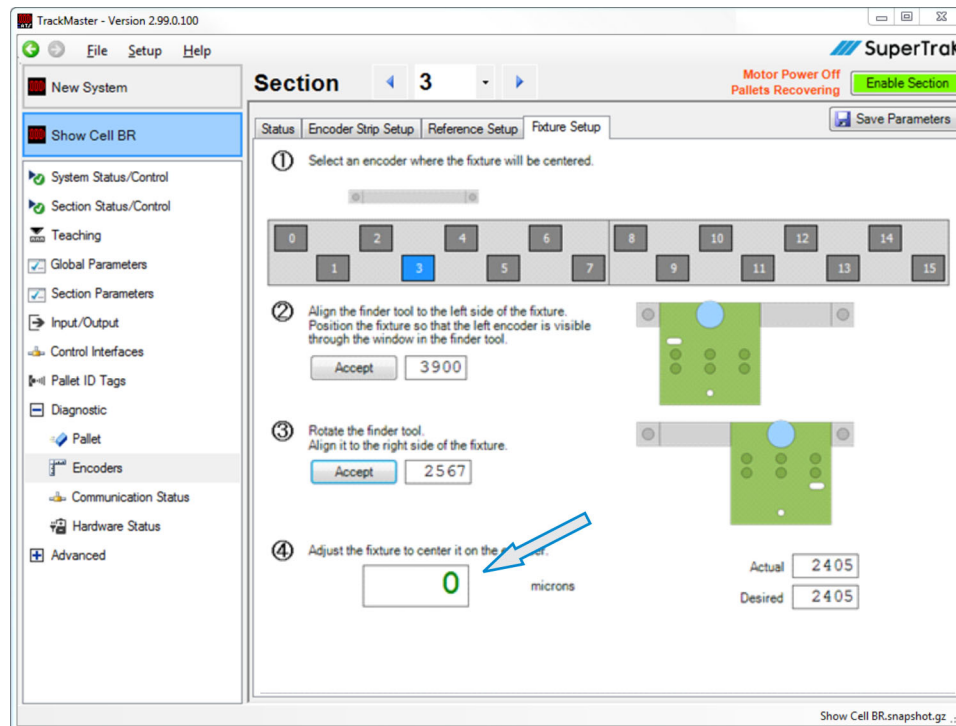

14. Tighten the two (2) stationary mount screws.

15. Snug the two (2) hex head bolts against the stationary mount.
16. Tighten the two (2) station locate lock nuts.
17. Loosen the adjust block screws, snug them up to each end of the stationary mount, and then tighten the screws.
18. Remove the chip finder from the stationary mount.

## Verify the Pallet Setup Stationary Mount Position

Complete this procedure to verify that the stationary mount is in the correct position. A pallet with a correctly aligned encoder assembly (master or reference pallet) is required for this procedure.

1. Install the pallet setup removable locate:

- a. Align a removable locate with the stationary mount.
- b. Firmly hold the removable locate back and to the left, and then tighten the two (2) top thumb screws.

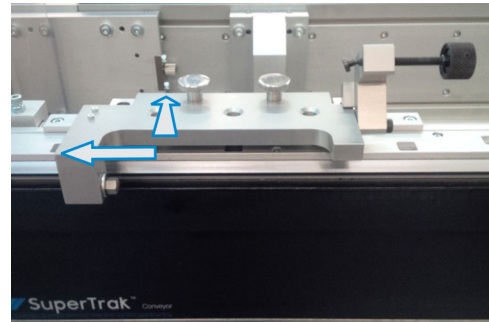

2. Lock a pallet in position:

- a. Lift the side thumb screw up.
- b. Slowly position a pallet with a correctly adjusted encoder assembly under the removable locate. This pallet is the master (reference) pallet.  
Do not force the pallet against the datum of the removable locate because this could shift the tooling out of position.

- c. Lower the side thumb screw down.
- d. Hold the pallet to the left, and then lightly tighten the side thumb screw to lock the pallet in position against the datum.

Pallet setups can vary by  $\pm 5$  microns if inconsistent pressure is applied. Use consistent pressure when locking a pallet in position.

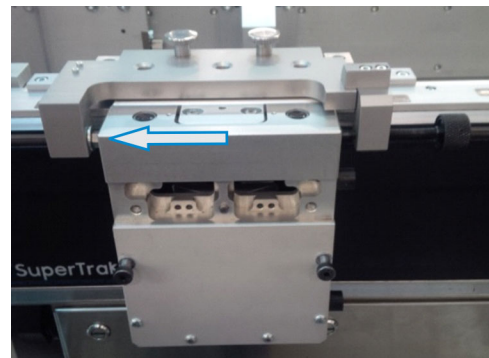

3. In the TrakMaster software, expand **Diagnostics**, and then click **Encoders**.
4. Click the **Encoder Strip Setup** tab.

- View the value displayed in step 2 on the TrakMaster screen. If the stationary mount is good, the value should be within  $\pm 4$  microns, like the example below.

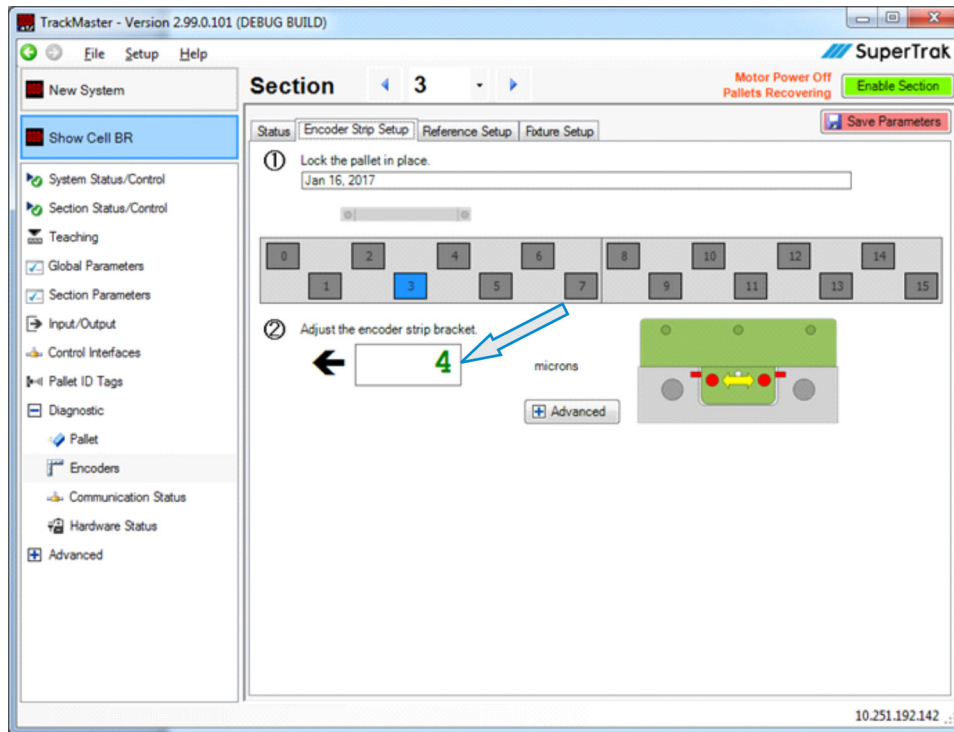

## Reference the Encoder Position

Complete this procedure to measure the physical distance between two encoders on the straight section encoder assembly.

Redo this procedure if an encoder assembly is replaced on a straight section that has a stationary mount installed.

1. Complete steps 1-4 of *Verify the Pallet Setup Stationary Mount Position* on page 223.
2. Click the **Reference Setup** tab.
3. Click the encoder that the stationary mount is aligned with.
4. Click **Capture Live Counts**.

The primary reference values display.

5. Click **Begin Sweep**.
6. Remove the pallet from the pallet setup removable locate:
  - a. Loosen the side thumb screw to release the pallet.
  - b. Raise the side thumb screw.
  - c. Slide the pallet to the right (~15 cm [~6 in.]).

TrakMaster calculates and displays the secondary reference values.

7. Click **Save Parameters**, located in the top right of the screen.

Encoder Configuration is selected by default on the Save Configuration dialog.

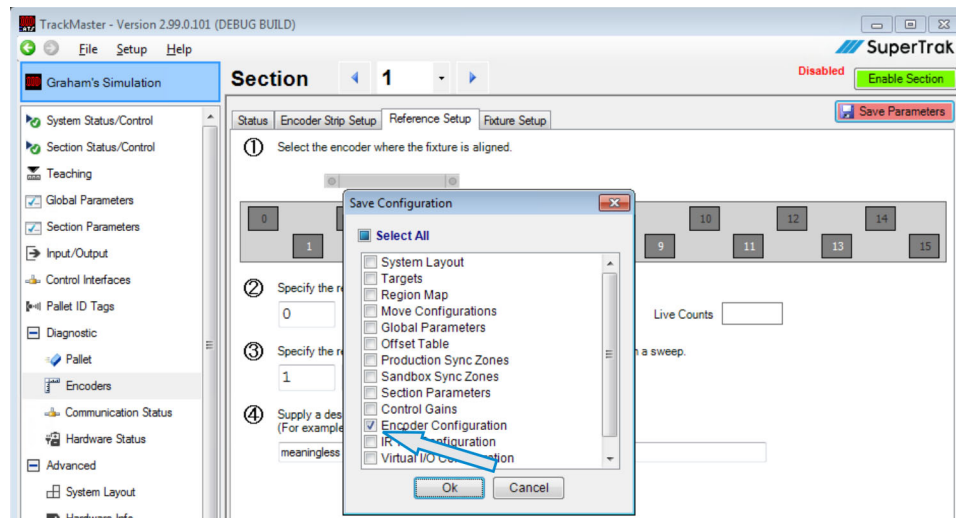

8. Click **OK**.
9. Note the following information for your records: your name, date, the pallet number that was used for the procedure, and the removable locate number.

## Adjust the Pallet Encoder Strip Assembly (Primary Encoder Strip)



For optimal pallet-to-pallet repeatability, make sure all the pallets on the SuperTrak have the same encoder strip assembly value in TrakMaster. It is more important for all pallet encoder strips to be set the same, than for the encoders to be set 0.

Adjust the pallet encoder strip assembly (primary encoder strip) if:

- The pallet encoder strip assembly is replaced.
- The pallet encoder strip assembly height is adjusted.
- An alignment issue is identified with the pallet (for example; the specific pallet causes a lot of faults, or the plot data is bad when the encoder calibration verification procedure is completed).

This procedure describes how to center the pallet encoder assembly with the center of the pallet.

1. Lock a pallet in position.
2. In the TrakMaster software, expand **Diagnostic**, and then click **Encoders**.
3. Click the **Encoder Strip Setup** tab.
4. View the value below step 2 (**Adjust the encoder strip bracket**) on the TrakMaster screen, and then complete one (1) of the following:
  - If the value is good (green), it will be within  $\pm 4$  microns. The procedure is complete.
  - If the value is not good (red), continue to step 5.
5. Slightly loosen the two (2) screws that secure the pallet encoder strip assembly in position. Only loosen the screws enough to make a fine movement.

Make sure the hex key is fully-engaged with the screw to avoid stripping the screw head.

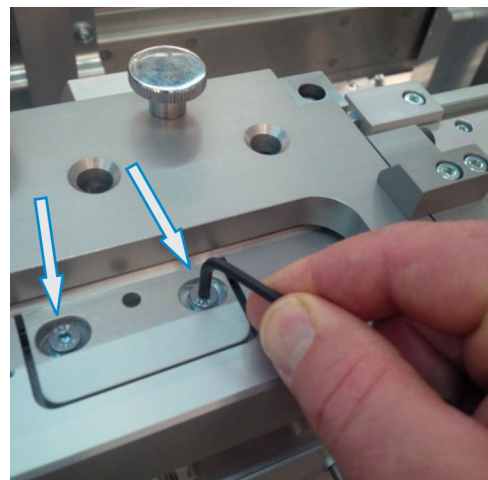

6. On each side of the encoder strip assembly, insert a hex key into the hole and engage the recessed set screw.

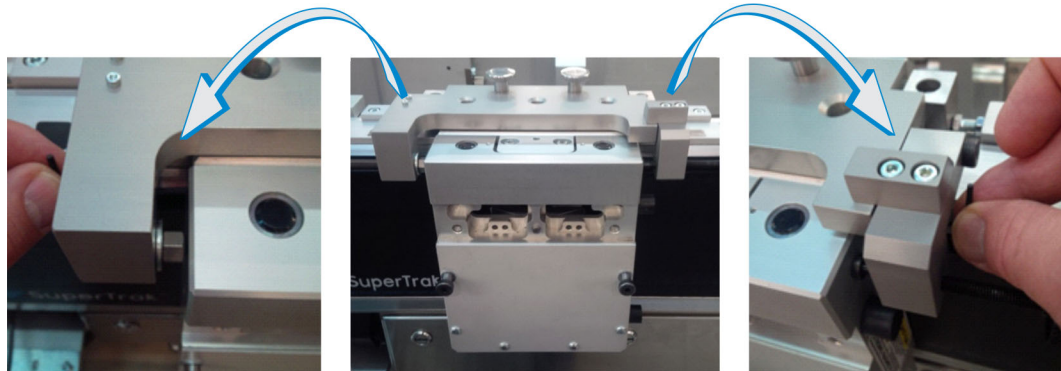

7. Turn the hex key(s) the required amount in the required direction to correctly adjust the encoder strip assembly. Aim for a pallet position that is within a few microns; the value on the TrakMaster screen should be green.

It is helpful to loosen one set screw as you tighten the other. Do not over-tighten these set screws, or the encoder strip assembly may shift out of position.

8. Tighten the two (2) encoder strip assembly screws from step 5.
9. Verify that the pallet position did not change (see step 4). If the value did change, repeat steps 4 to 8.

### Adjust a Secondary Encoder Strip

**NOTICE**

During this procedure, do not over-tighten the side screws because it can bend the secondary strip.

This procedure describes how to align the secondary encoder strip with the primary encoder strip. Complete this procedure if a pallet is causing faults, and the primary strip alignment has already been verified.

1. Verify that the primary encoder strip is aligned.  
See [Adjust the Pallet Encoder Strip Assembly \(Primary Encoder Strip\)](#) on page 226.
2. Remove the pallet from the pallet setup removable locate:
  - a. Loosen the side thumb screw to release the pallet.
  - b. Raise the side thumb screw.
  - c. Slide the pallet to the right.

3. Loosen the three (3) screws on the edge of the pallet encoder strip assembly. Only loosen the screws enough to make a fine movement.

Make sure the hex key is fully-engaged with the screw to avoid stripping the screw head.

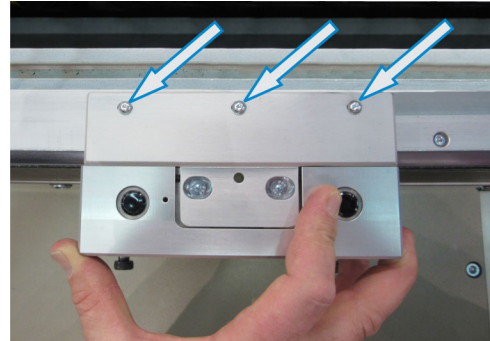

4. Install an M2.5 x10 mm screw into each side of the pallet encoder strip assembly. Do not over-tighten the screws.



5. Install the pallet below the removable locate.

Slide the pallet in position slowly. Make sure the pallet does not bang against the datum of the removable locate because this could shift the tooling out of position.



6. On TrakMaster, click **+ Advanced**.  
If required, click **Diagnostic > Encoders**, and then click the **Encoder strip Setup** tab first.
7. View the value below step 3 (**Make a coarse adjustment to the secondary strip**) on the TrakMaster screen, and then complete one (1) of the following:
  - If the value is good (green), continue to step 9.  
This value may not be zero (0), especially if the strip was previously aligned correctly. The goal is to align the secondary strip close enough to enable the fine adjustment.
  - If the value is not good (red), continue to step 8.
8. As required, turn the side screws (from step 4) the required amount and in the required direction until the value is good (green).  
The secondary strip is pinched between the side screws. Do not over-adjust the screws because it could bend the secondary strip.
9. Click **Accept**.
10. Slide (sweep) the pallet to the right, away from the removable locate:
  - a. Loosen the side thumb screw to release the pallet.
  - b. Raise the side thumb screw.
  - c. Slide the pallet to the right (~15 cm [~6 in.]).
11. Repeat steps 6.
12. View the value below step 5 (**Lock the pallet again, and make a fine adjustment to the secondary strip.**) on the TrakMaster screen, and then complete one (1) of the following:
  - If the value is good (green), continue to step 13.  
Aim for a value close to zero (0).
  - If the value is not good (red), repeat step 8.
13. Tighten the three (3) screws from step 3.
14. Verify that the values are still good.
15. Click **Finish**.
16. Remove the two (2) screws from step 4.

## Replace an Upper V-Rail

Replace the upper v-rail if it becomes damaged.

### Replace an Upper V-Rail - Straight Section

#### Remove an Upper V-Rail - Straight Section

1. Turn the **SuperTrak conveyance platform power disconnect switch** to the OFF position.
2. Lock out and tag hazardous energy.  
See [Lockout and Tagout Locations](#) on page 12.
3. Remove the left and right encoder assemblies.  
See [Remove an Encoder Assembly - Straight Section](#) on page 165.
4. Remove eleven (11) screws from the upper v-rail.



5. Note the position of the 0.25 mm (0.01 in.) shim, and then place the shim in a safe location.
6. Slide the upper v-rail out in the forward direction clear of the motor.  
The v-slots at the ends of the upper v-rail prevent it from being lifted straight up.

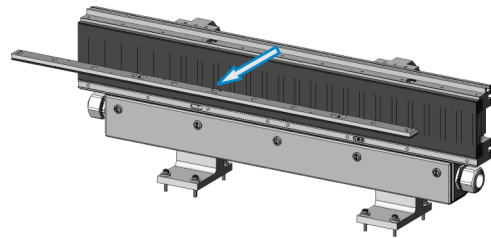

7. Clean the top of the straight section with a soft cloth to remove any debris.

#### Install an Upper V-Rail - Straight Section

1. Hold the new upper v-rail horizontally, with the counter-bore side up.
2. Slide the new upper v-rail between the upper v-rails of the adjacent straight sections.

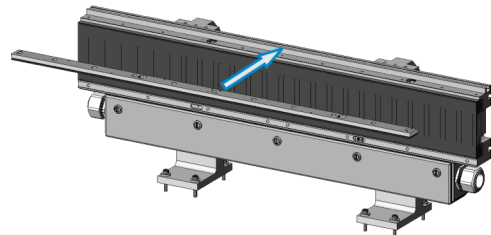

3. Equally divide the gap between the ends of the upper v-rail.  
The gap should be close to 0.5 mm (0.02 in.) on both sides.
4. Install the 0.25 mm (0.01 in.) shims. Restore them to the position you made note of during the removal procedure.
5. Install eleven (11) screws into the top of the upper v-rail, while keeping the back of the upper v-rail biased to the structure.
6. Reinstall the left and right encoder assemblies.

See [Install an Encoder Assembly - Straight and Curved Sections](#) on page 167.

### Replace an Upper V-Rail - 180 Deg. (800 mm) Section

#### Remove an Upper V-Rail - 180 Deg. (800 mm) Section

1. Turn the **SuperTrak conveyance platform power disconnect switch** to the OFF position.
2. Lock out and tag hazardous energy.  
See [Lockout and Tagout Locations](#) on page 12.
3. Remove the four encoder assemblies.

See [Remove an Encoder Assembly - Curved Sections](#) on page 166.

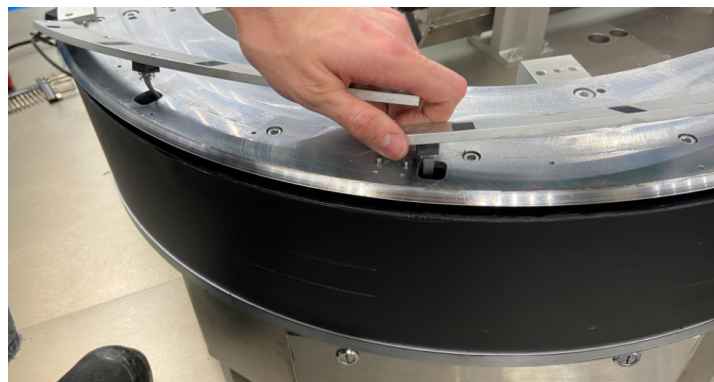
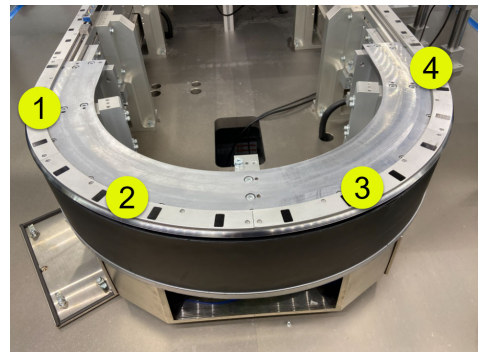

4. Remove twenty one (21) screws from the upper v-rail.

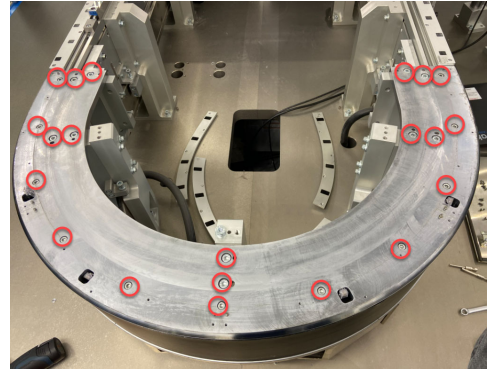

5. Loosen the screws that attach the section's stands to the frame as indicated at right.

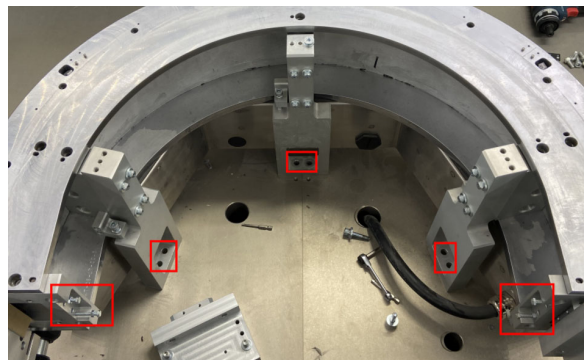

6. Loosen the adjacent straight sections' V-rails. Do not remove them completely, but loosening them will make it easier to install the new V-rails on the 180 deg. (800) section.

See [Remove an Upper V-Rail - Straight Section](#) on page 230.

7. Slide entire curved section out slightly from the rest of the track to create clearance space.
8. Lift curved V-rail (lifting adjacent V-rails as well) to clear dowel pins and then slide V-rail out of the section.

The v-slots at the ends of the upper v-rail prevent it from being lifted straight up.



9. Clean the top of the section with a soft cloth to remove any debris.

*Install an Upper V-Rail - 180 Deg. (800 mm) Section*

1. Hold the new upper v-rail horizontally, with the counter-bore side up.
2. Slide the new upper v-rail between the upper v-rails of the adjacent sections.
3. Equally divide the gap between the ends of the upper v-rail.  
The gap should be close to 0.5 mm (0.02 in.) on both sides.
4. Install the 0.25 mm (0.01 in.) shims. Restore them to the position you made note of during the removal procedure.
5. Install the twenty one (21) screws into the top of the upper v-rail, while keeping the back of the upper v-rail biased to the structure.
6. Reinstall the left and right encoder assemblies.

See [Install an Encoder Assembly - Straight and Curved Sections](#) on page 167.

**Replace an Upper V-Rail - 90 Deg. Section**

*Remove an Upper V-Rail - 90 Deg. Section*

1. Turn the **SuperTrak conveyance platform power disconnect switch** to the OFF position.
2. Lock out and tag hazardous energy.

See [Lockout and Tagout Locations](#) on page 12.

3. Remove section's encoder assemblies as well as the encoder assemblies on the adjacent sections.

See [Remove an Encoder Assembly - Straight Section](#) on page 165.

See [Remove an Encoder Assembly - Curved Sections](#) on page 166.

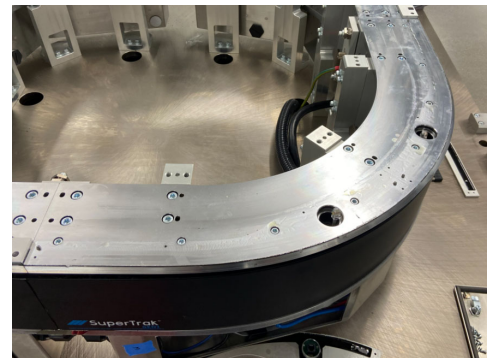

4. Remove fifteen (15) screws from the upper v-rail, and remove the screws from the adjacent sections as well.

See [Replace an Upper V-Rail - Straight Section](#) on page 230.

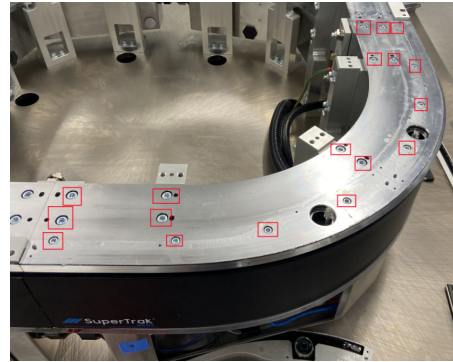

5. Note the position of the 0.25 mm (0.01 in.) shim, and then place the shim in a safe location.
6. Lifting the section of interest, free adjacent V-slots between this section and adjacent sections so that the V-rail is free to be lifted the rest of the way.

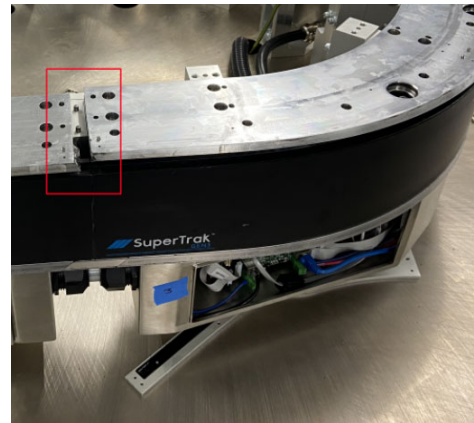

7. Slide the upper v-rail out in the forward direction clear of the motor.  
The v-slots at the ends of the upper v-rail prevent it from being lifted straight up.
8. Clean the top of the section with a soft cloth to remove any debris.

*Install an Upper V-Rail - 90 Deg. Section*

1. Hold the new upper v-rail horizontally, with the counter-bore side up.
2. Slide the new upper v-rail between the upper v-rails of the adjacent sections.
3. Equally divide the gap between the ends of the upper v-rail.  
The gap should be close to 0.5 mm (0.02 in.) on both sides.
4. Install the 0.25 mm (0.01 in.) shims. Restore them to the position you made note of during the removal procedure.
5. Re-install the fifteen (15) screws into the top of the upper v-rail, while keeping the back of the upper v-rail biased to the structure.
6. Reinstall the encoder assemblies on the 90 deg. section and adjacent sections.  
See [Install an Encoder Assembly - Straight and Curved Sections](#) on page 167.

**Replace an Upper V-Rail - 180 Deg. (500 mm) Section**

*Remove an Upper V-Rail - 180 Deg. (500) Section*

1. Turn the **SuperTrak conveyance platform power disconnect switch** to the OFF position.
2. Lock out and tag hazardous energy.  
See [Lockout and Tagout Locations](#) on page 12.
3. Remove the upper v-rail from the two (2) adjacent straight sections.  
See [Remove an Upper V-Rail - 180 Deg. \(500\) Section](#) on page 235.
4. Remove the left and right encoder assemblies from the 180 deg. section.  
See [Remove an Encoder Assembly - Curved Sections](#) on page 166.
5. Remove ten (10) screws and ten (10) washers from the top cover of the 180 deg. section, and then lift and remove the top cover.



6. Remove eleven (11) screws from the top plate.

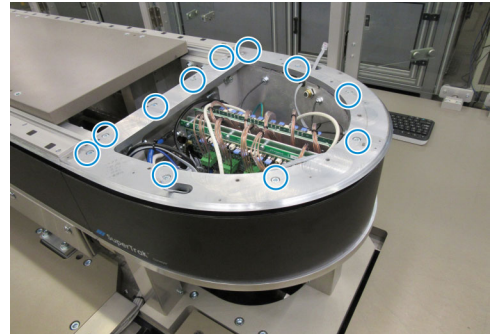

7. Lift the top plate straight up to remove it.
8. Clean the top of the 180 deg. section with a soft cloth to remove any debris.



9. Verify joint alignment on both ends and adjust if necessary.

See *Fine-Adjust the Upper V-Rail* on page 103.

10. Calibrate the encoders.

See the TrakMaster built-in help for the calibration procedure.

*Install an Upper V-Rail - 180 Deg. Section 180 Deg. (500 mm) Section*

1. Hold the new 180 deg. top plate horizontally with the counter-bore side up.
2. Position the top plate down onto the top of the 180 deg. section.

The top plate must align with features in the top of the 180 deg. section.

To prevent damage to the RJ11 connections, make sure the cables are aligned with the RJ11 openings in the top plate.



3. Install eleven (11) screws to secure the top plate in position.
4. Align the top cover on the 180 deg. section.
5. Install ten (10) screws and ten (10) washers to secure the top cover in position.
6. Reinstall the left and right encoder assemblies.  
See *Replace an Encoder Assembly* on page 165.
7. Verify joint alignment on both ends and adjust if necessary.  
See *Fine-Adjust the Upper V-Rail* on page 103.
8. Calibrate the encoders.  
See the TrakMaster built-in help for the calibration procedure.

## Replace a Flat Wear Strip

**NOTICE**

- The flat wear strip must be installed before pallets move on the SuperTrak conveyance platform. If a flat wear strip is not installed, pallets will jam against the motors.
- The distance between flat wear strips must be 0.5 mm (0.02 in.).

Replace a flat wear strip if it becomes damaged.

There are several flat wear strip lengths, depending on the type of sections:

Description	Length	Part Number
Straight to straight	1.01 m (3.31 ft)	SP-1060669
Straight to 180 deg. (500 mm)	.52 m (1.70 ft)	SP-1060640
Straight to 180 deg. (800 mm) and Straight to 90 deg.	.54 m (1.77 ft)	SP-25284328
90 deg. to 90 deg.	.075 m (0.25 ft)	SP-125595093

*Note that flat wear strip lengths are measured from the furthest ends of each angle as pictured.*

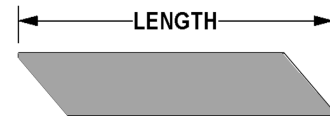

As illustrated in the example below showing a system configuration with straight and 180 deg. (500 mm) sections, the flat wear strip bridges the join between each SuperTrak conveyance platform section:

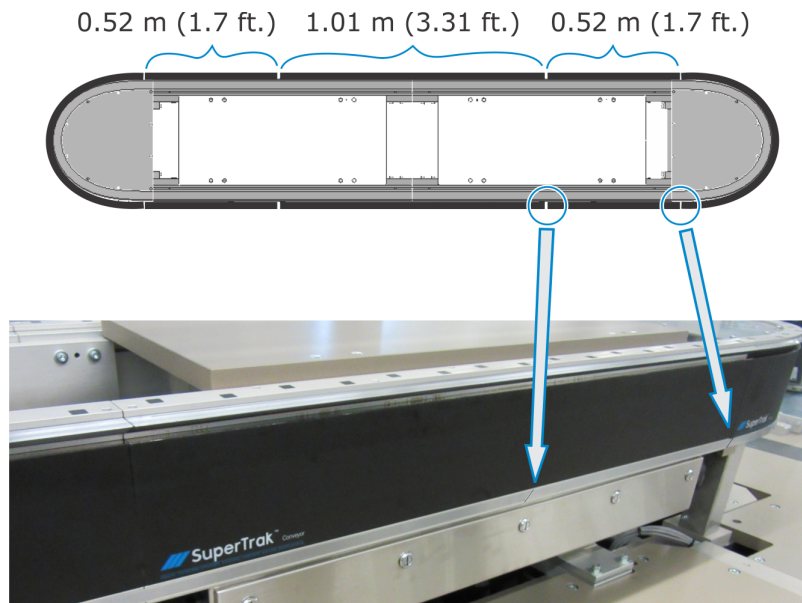

## Remove a Flat Wear Strip

1. Open the safety circuit.
2. Place a strong magnet on the front surface of one end of the wear strip.



3. Holding onto the magnet, pull the wear strip straight out of the channel.  
The flat wear strip is held in position with permanent magnets. Use the magnet to pull the flat wear strip away from the permanent magnets.



4. Remove any dirt or debris from the flat wear strip channel.  
See [Clean the SuperTrak Conveyance Platform](#) on page 247.

## Install a Flat Wear Strip

1. Verify that the flat wear strip is the correct length for the installation location.
2. Hold the flat wear strip next to the installation location and verify that a locator exists where the slot of the wear strip aligns with the SuperTrak conveyance platform section.

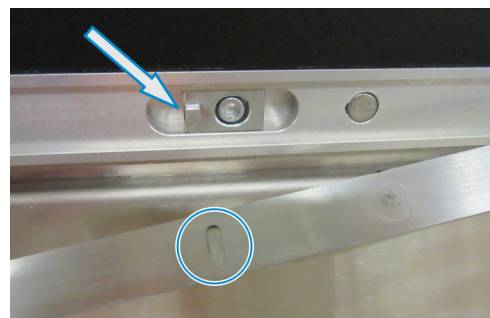

3. If required, install a locator:
  - a. Align the locator with the slot of the SuperTrak conveyance platform section so that the tab faces the long opening. The screw hole is not centered in the slot, one side of the slot is longer than the other.

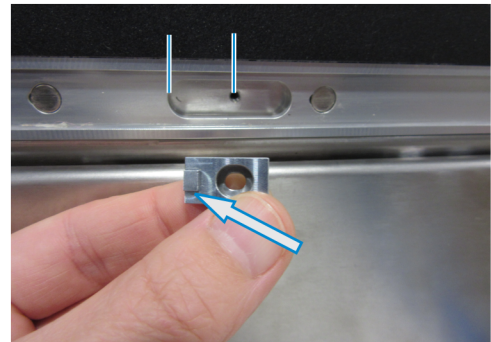
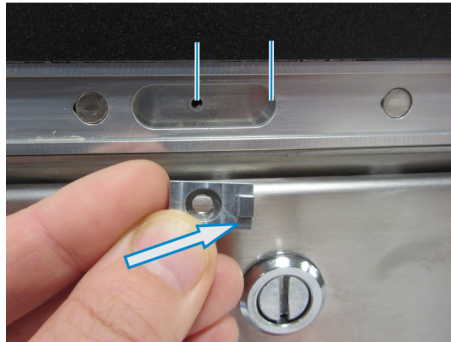

- b. Install a screw to secure the locator in position.

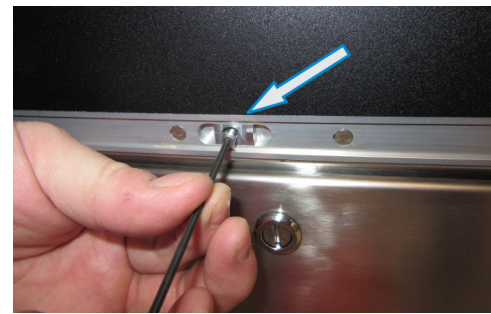

4. Align the flat wear strip slot with the locator tab.

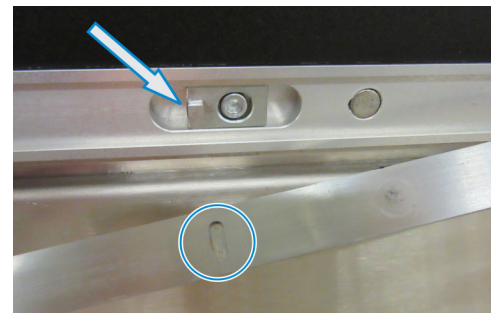

5. Release the flat wear strip. The channel magnets pull the flat wear strip into the channel.
6. If the flat wear strip does not sit flat in the channel, adjust the locator position:
  - a. Loosen the locator screw.
  - b. As required, slide the locator left or right.
  - c. Tighten the locator screw.
7. If the flat wear strip joint between a straight section and a 180 deg. section does not sit flat, see [Align a Flat Wear Strip](#) on page 241.

### Align a Flat Wear Strip

Adjustment tooling, located under the curved section, provides in-and-out adjustment of the flat wear strip on the curved section. The process for aligning the flat wear strips varies slightly depending on the type of curved section, as outlined below.

#### 180 Deg. (500 mm) Section

1. Loosen the two (2) screws that secure the flat wear strip adjustment tooling in position

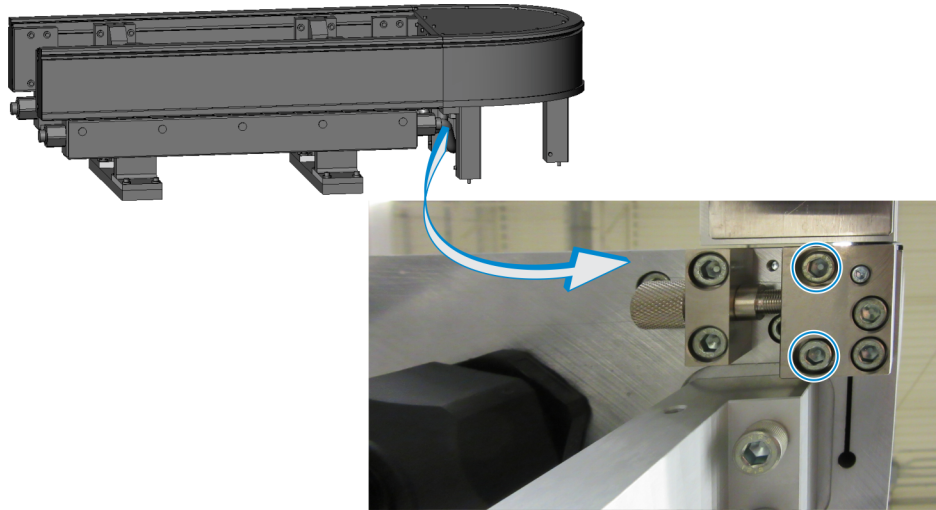

2. Turn the adjustment knob as required, until the flat wear strip on the curved section aligns with the flat wear strip on the straight section.
3. Tighten the two (2) screws from step 1.

#### 180 Deg. (800 mm) Section

If the wear strip is protruding, remove the wear strip spacer and grind the back face as needed.

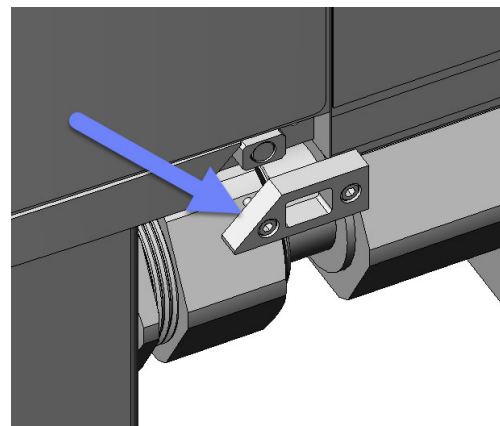

90 Deg. Section

To align the wear strip, use the screws as labeled to adjust the wear strip in and out.

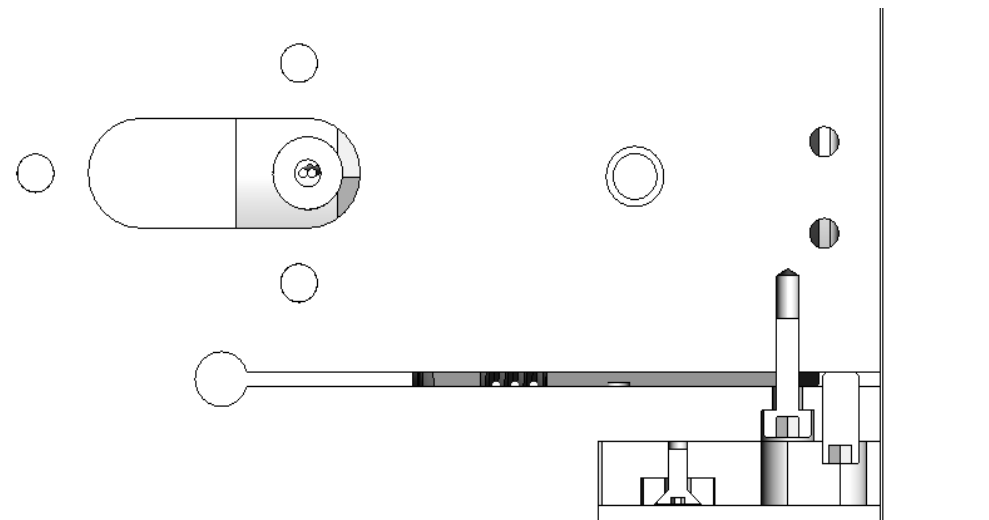
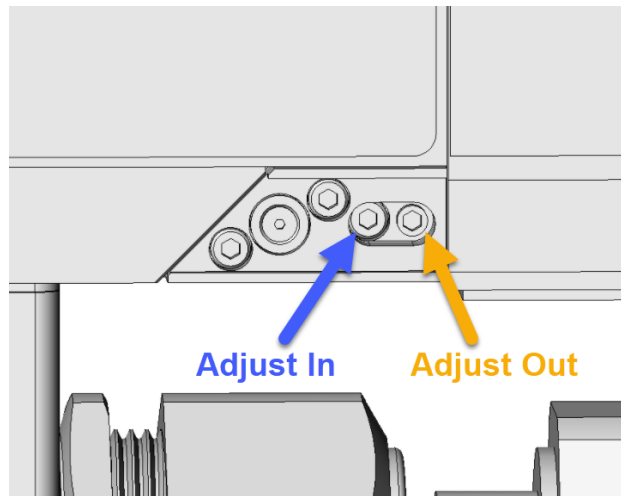

## Replace a Motor Cover Label

Each motor includes a protective motor cover label. This is the black label with the SuperTrak conveyance platform logo in the bottom left corner. Replace the motor cover label if it becomes damaged.

### Remove the Damaged Motor Cover Label

1. Turn the **SuperTrak conveyance platform power disconnect switch** to the OFF position.
2. Lock out and tag hazardous energy.  
See [Lockout and Tagout Locations](#) on page 12.
3. Peel off the old cover label.
4. Clean off any adhesive residue from the motor face.

Use an adhesive residue cleaner (such as Goo Gone) to remove the adhesive residue, and then clean the motor with isopropyl alcohol or equivalent so the new cover label adheres correctly.

### Install a New Motor Cover Label

1. Peel off the backing from the new motor cover label.
2. Align the top of the motor cover label with the top edge of the motor.



3. Slowly tilt the motor cover label toward the motor until it is adhered to the motor.
4. Starting from the center of the motor cover label, run your hands over the label to remove any air pockets.
5. Trim away any portions of the motor cover label that extend past the edge of the motor.

## Replace a Straight Section

Although both options are available, Automation Tooling Systems recommends that straight sections be repaired rather than replaced.

See [Appendix B: Spare Parts](#) on page 289.

## Replace a 180 Deg. Section

Although both options are available, Automation Tooling Systems recommends that 180 deg. sections be repaired rather than replaced.

See [Appendix B: Spare Parts](#) on page 289.



# Maintenance

Maintenance is an important part of the continued and proper operation of the SuperTrak conveyance platform. Failure to perform maintenance as required, and in accordance with your ATS contract, voids the warranty. Maintain accurate and complete records regarding SuperTrak conveyance platform maintenance and any completed service procedures.

Warranty excludes consumable items and wear parts, such as but not limited to fuses, filters, or lubricants, which by their nature require periodic replacement.

All technicians involved with maintaining the SuperTrak conveyance platform must be qualified and must read and understand the SuperTrak conveyance platform process and safety guidelines.

See [Safety Information](#) on page 5.

This section provides the following SuperTrak conveyance platform maintenance information:

- [Scheduled Maintenance](#) on page 245
- [Cleaning Procedures](#) on page 247
- [Lubrication Procedures](#) on page 250

## Scheduled Maintenance

### NOTICE

The scheduled maintenance tables in this section provide a recommended frequency for each maintenance task. Adjust the frequency according to your installation environment. For example; cleaning may need to be more or less frequent, depending on the environment.

This section provides SuperTrak conveyance platform preventive maintenance tables.

## SuperTrak Conveyance Platform Components

Component	Frequency	Task	Description
Flat wear strip	Weekly	Clean	Clean off debris, using a clean, soft cloth dampened with isopropyl alcohol or equivalent.

Component	Frequency	Task	Description
Pallets	Monthly	Inspect	Inspect each pallet for wear. See <a href="#">Inspect a Pallet</a> on page 195.
	Monthly, or as determined for your application	Lubricate	Add lubricant to the pallet. See <a href="#">Lubricate the Pallet Lubrication Felt</a> on page 250.
	Monthly	Clean	<ul style="list-style-type: none"> <li>• Clean the pallet body. Wipe off debris using a clean, soft, cloth.</li> <li>• Clean the magnet assembly. Wipe metal debris to a corner or edge of the magnet and then pull it off.</li> <li>• Clean the pallet encoder strip. See <a href="#">Clean a Pallet Encoder Strip</a> on page 248.</li> </ul>
Power supply	Monthly	Inspect	Inspect the air filter for dirt and debris. If required, replace the filter. See <a href="#">Replace a Power Supply Filter</a> on page 249.
Table and Supporting Structure	Weekly	Clean	Clean off debris, using a clean, soft cloth.

## Electrical Enclosure

Component	Frequency	Task	Description
Fan	Monthly	Inspect	Inspect for damage and loose connections. If required, repair or replace.
	As Required	Clean	Clean off debris, using a clean, soft cloth.
Filter	Monthly	Inspect	Inspect the condition of the filter. If required, vacuum, wash or replace. See <a href="#">Clean a Control Panel Air Filter</a> on page 247.

## Cleaning Procedures

This section describes SuperTrak conveyance platform cleaning procedures.

### Clean the SuperTrak Conveyance Platform

**CAUTION**

After cleaning the SuperTrak conveyance platform frame, clean up all spills and excess water immediately. Liquid on floors causes a slip hazard.

**NOTICE**

Never use razor blades, scrapers, squeegees, brushes or any other abrasive tools to clean the SuperTrak conveyance platform frame. Use of these tools may cause damage.

#### Remove Dust and Dirt

1. Wipe with a soft damp cloth to remove dust and dirt.
2. Wipe with a mild detergent on a soft cloth.
3. Wipe with a damp soft cloth to remove detergent.
4. Dry with a clean soft cloth or chamois.

#### Remove Wet Paint, or Grease

1. Wipe with a clean soft cloth dampened with isopropyl alcohol or equivalent.
2. Dry with a clean soft cloth or chamois.

### Clean a Control Panel Air Filter

Air filters are located on the side of the control panel.

1. Carefully remove the front plastic filter support.
2. Gently peel back the sponge filter.
3. Use a vacuum to carefully remove any particulate from the filter unit.
4. Replace the filter.
5. Snap the filter cover back into position over the filter.

## Clean a Pallet Encoder Strip

**NOTICE**

Never use a magnet to clean the encoder strip. Contact with magnetic material will cause permanent damage to the magnetic encoder strip.

1. Gently wipe the encoder strip with a soft, dry, clean cloth.
2. Inspect the encoder strip, to make sure it is not damaged.

See [Inspect a Pallet Encoder Strip](#) on page 248.

## Inspect a Pallet Encoder Strip

Inspect the encoder strip with magnetic viewing film, to verify that the poles appear correctly.

Each pole should be vertical to one another. If the poles appear damaged, replace the encoder strip.

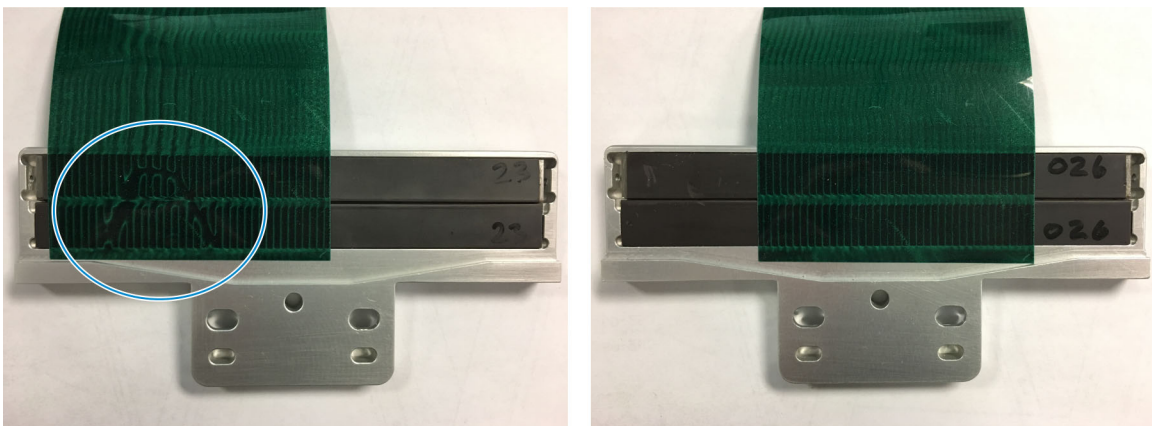

## Replace a Power Supply Filter

**NOTICE**

Be careful not to bend the power supply filter retention clip out of shape when removing it.

The power supply filter prevents particles from entering the power supply through the cooling fans. Particulate build-up on the power supply filter impedes air flow and may cause the power supply to overheat.

Power supply filter replacement frequency depends on the SuperTrak conveyance platform environment. Regularly inspect the power supply filter and replace it when it is dirty.

1. Carefully compress one end of the filter retention clip until one end releases from the power supply cabinet tab.

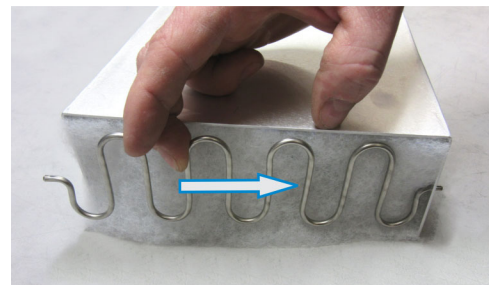

2. Remove the filter retention clip.
3. Remove the old filter.
4. Clean away any excess grit or dirt in and around the power supply fans.

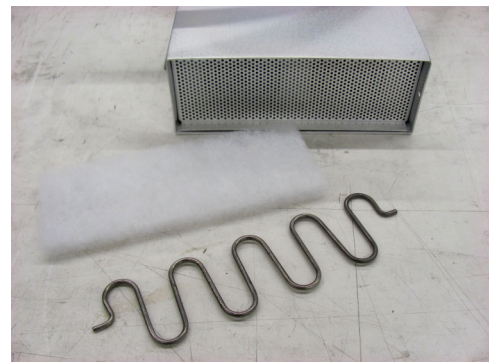

5. Position a new filter into the base of the power supply.  
The filter is not directional, so it can be positioned with either side facing either direction.
6. Place one end of the filter retention clip into the power supply cabinet tab, and then carefully compress the filter retention clip to secure the opposite end into the cabinet tab on the opposite side.

## Lubrication Procedures

This section provides lubrication procedures.

### Lubricate the Pallet Lubrication Felt

**NOTICE**

Determine and maintain a lubrication schedule for your application, to ensure that the upper v-rail and pallet lubrication felts do not run dry.



Use an oil lubricant with a viscosity similar to ISO grade 46, SAE grade 20. ATS uses a food grade NSF registered H1 machine oil for the broadest application range.

The lubrication felt lubricates the upper v-rail.

Place five (5) to ten (10) drops of lubricant into the lubrication hole at the top of the pallet.

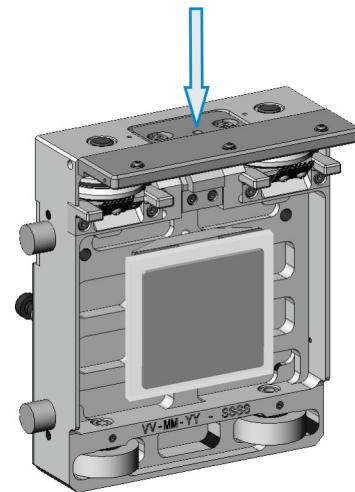

# Troubleshooting

This section provides the following SuperTrak conveyance platform troubleshooting procedures for qualified technicians:

- [Communication Faults](#) on page 251
- [Pre-Power ON Faults](#) on page 252
- [Power Faults](#) on page 255
- [Pallet Faults](#) on page 258
- [Test Straight Section or Curved Section Hardware](#) on page 259
- [Diagnostic Lights](#) on page 267

Read and understand the SuperTrak conveyance platform process and safety guidelines before starting any troubleshooting procedures.

See [Safety Information](#) on page 5.

## Communication Faults

Fault	Resolution
<p>The configuration software is unable to connect to the controller.</p>	<ul style="list-style-type: none"> <li>• Attempt to retrieve diagnostic information using the following website: <a href="http://controller_IP_address/sdm">http://controller_IP_address/sdm</a> The IP address of the controller is required for this procedure.</li> <li>• Check the controller LEDs. See <a href="#">Controller Indicator Lights</a> on page 267.</li> </ul>
<p>A fault message indicates that a communication problem exists.</p>	<ol style="list-style-type: none"> <li>1. Read the fault message, and reference the TrakMaster built-in help for a resolution. See <a href="#">Access the TrakMaster Built-in Help</a> on page 141.</li> <li>2. Verify that all associated electronic components have power (for example; confirm power by looking at the component indicator lights).</li> <li>3. Turn the power OFF to the controller and gateway boards (24V digital power).</li> <li>4. Verify that all associated cables are correctly connected. Make sure the cable connections are correct to the components, and that the connectors are seated correctly at both ends. See <a href="#">Connections</a> on page 116.</li> <li>5. Turn the power ON.</li> </ol>

# Pre-Power ON Faults

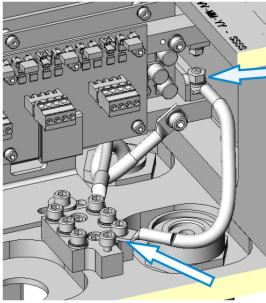
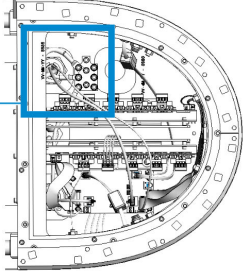
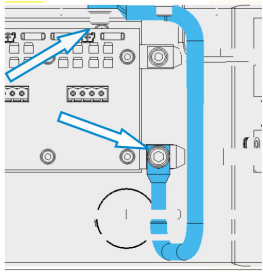
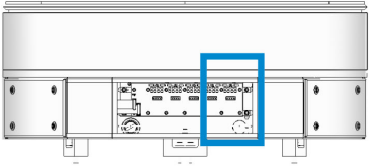
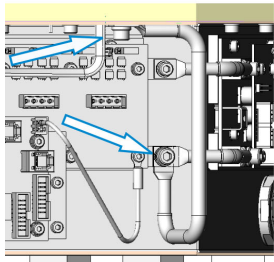
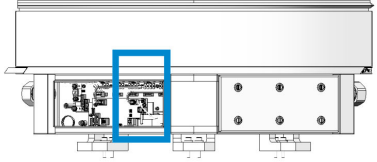
Failure	Resolution
<p>A short exists between the motor power connection and the common connection or ground (frame).</p>	<p>Determine if the short exists between a motor power connection and a common connection or between a motor power connection and ground (frame):</p> <ol style="list-style-type: none"> <li>1. Disconnect and isolate one (1) end of the common bonding jumper located in the 180 deg. section that contains the control panel electrical interconnect.</li> </ol> <div style="display: flex; flex-direction: column; align-items: center;"> <div style="display: flex; justify-content: space-around; width: 100%;"> <div style="text-align: center;">  </div> <div style="text-align: center;">  <p>180 deg. (500 mm)</p> </div> </div> <div style="display: flex; justify-content: space-around; width: 100%; margin-top: 20px;"> <div style="text-align: center;">  </div> <div style="text-align: center;">  <p>180 deg. (800 mm)</p> </div> </div> <div style="display: flex; justify-content: space-around; width: 100%; margin-top: 20px;"> <div style="text-align: center;">  </div> <div style="text-align: center;">  <p>90 deg.</p> </div> </div> </div> <ol style="list-style-type: none"> <li>2. Use a multimeter to measure the resistance between the motor power connection and the common connection. If the value displayed on the multimeter screen is OL, the short exists between the motor power connection and ground (frame). If the value displayed on the multimeter screen is <math>&lt;5\Omega</math>, the short exists between the motor power connection and the common connection.</li> </ol>

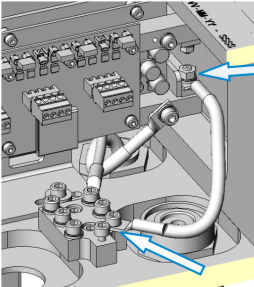
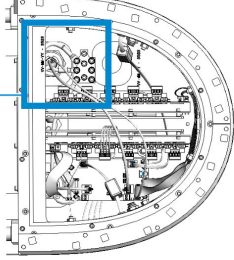
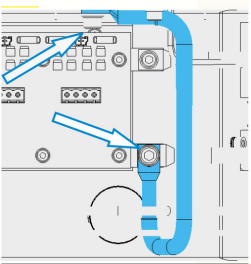
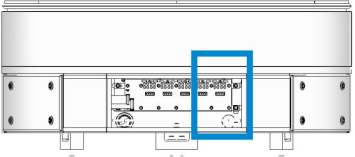
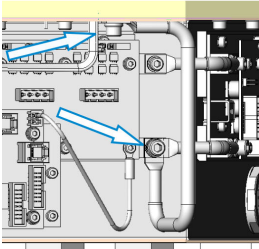
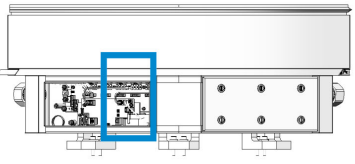

Failure	Resolution
Continued from previous page	<p>Isolate the short:</p> <ol style="list-style-type: none"> <li>1. Disconnect a motor power connection at each end of the system. This divides the system in half electrically.</li> <li>2. Use a multimeter to measure the resistance of each half of the system. The half of the system with a measurement of <math>&lt;5\Omega</math> is the half containing the short.</li> <li>3. Disconnect a motor power connection in the middle of the isolated half of the system.</li> <li>4. Repeat step 2.</li> <li>5. Locate the connection between the motor power connection and the common connection or ground (frame).</li> </ol>
A short exists between the 24V digital power connection and the common connection or ground (frame).	<p>Determine if the short exists between a 24V digital power connection and a common connection or between a 24V digital power connection and ground (frame):</p> <ol style="list-style-type: none"> <li>1. Disconnect and isolate one (1) end of the common bonding jumper located in the 180 deg. section that contains the control panel electrical interconnect.</li> </ol> <div style="display: flex; flex-direction: column; align-items: center;"> <div style="display: flex; justify-content: space-around; width: 100%;">   </div> <p style="text-align: right; margin-right: 50px;"><i>180 deg. (500 mm)</i></p> <div style="display: flex; justify-content: space-around; width: 100%;">   </div> <p style="text-align: right; margin-right: 50px;"><i>180 deg. (800 mm)</i></p> <div style="display: flex; justify-content: space-around; width: 100%;">   </div> <p style="text-align: right; margin-right: 50px;"><i>90 deg.</i></p> </div>



Failure	Resolution
Continued from previous page	<ol style="list-style-type: none"> <li>2. Use a multimeter to measure the resistance between the 24V digital power connection and the common connection. If the value displayed on the multimeter screen is OL, a short exists between the 24V digital power connection and the ground (frame). If the value displayed on the multimeter screen is <math>&lt;1000\Omega</math>, the short exists between the 24V digital power connection and the common connection.</li> </ol> <p>Isolate the short:</p> <ol style="list-style-type: none"> <li>1. Disconnect a 24V digital power connection at each end of the system. This divides the system in half electrically.</li> <li>2. Use a multimeter to measure the resistance of each half of the system. The half of the system with a measurement of <math>&lt;1000\Omega</math> is the half containing the short.</li> <li>3. Disconnect a 24V digital power connection in the middle of the isolated half of the system.</li> <li>4. Repeat step 2.</li> <li>5. Locate the connection between the 24V digital power connection and common connection or ground (frame).</li> </ol>
A short exists between the motor power connection and the 24V digital power connection.	<p>Isolate the short:</p> <ol style="list-style-type: none"> <li>1. Disconnect a 24V digital power connection at each end of the system. This divides the system in half electrically.</li> <li>2. Use a multimeter to measure the resistance of each half of the system. The half of the system with a measurement of <math>&lt;10\Omega</math> is the half containing the short.</li> <li>3. Disconnect a 24V digital power connection in the middle of the isolated half of the system.</li> <li>4. Repeat step 2.</li> <li>5. Locate the connection between the motor power connection and the 24V digital power connection.</li> </ol>



## Power Faults

Fault	Resolution
Motor supply voltage	<ul style="list-style-type: none"> <li>• Make sure the motor power is ON before attempting to enable the SuperTrak conveyance platform. This is typically a PLC programming error.</li> <li>• Verify that the breakers in the SuperTrak conveyance platform control panel are ON.</li> <li>• Verify that all power supplies are functioning correctly, and that all power wiring is installed correctly and securely.</li> <li>• Check the 50A main motor fuse(s) and replace if necessary. See <a href="#">Install a Power Supply</a> on page 145.</li> </ul>
Motor I2T	<ul style="list-style-type: none"> <li>• Check for a mechanical interference with the pallet. The fault indicates the location.</li> <li>• Verify that pallet performance limits (such as pallet acceleration, duty cycle, or payload) are not exceeded. Reduce if required. The fault indicates the location.</li> <li>• Check the pallet stability. Watch the pallet during operation for abnormal oscillation. Contact maintenance to verify pallet tuning.</li> <li>• Replace the coil driver board, if no other solution resolves the issue. See <a href="#">Replace a Coil Driver Board</a> on page 150.</li> </ul>
Excessive current loop error	<ul style="list-style-type: none"> <li>• Verify that the coil is correctly connected to the coil driver board (green connectors).</li> <li>• Test the coil resistance. It should be low (less than 1 ohm) but not a short-circuit (less than 0.3 ohm). If the resistance test fails, a problem may exist with the coil. Replace the coil. If the resistance test passes, a problem may exist with the coil driver board. Replace the coil driver board.</li> </ul>
Coil driver(s) shut down error	<ul style="list-style-type: none"> <li>• Verify that the power supplies are functioning correctly.</li> <li>• A problem may exist with the coil driver board. Replace the coil driver board.</li> </ul>

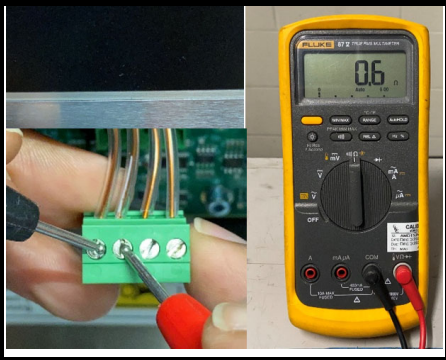
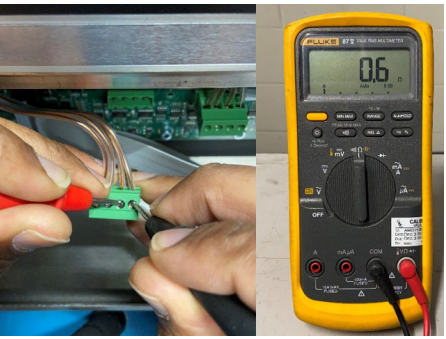
## Check Coil Resistance to Find Shorted or Mis-wired Coils

Use a multimeter to check for shorted or mis-wired coils.

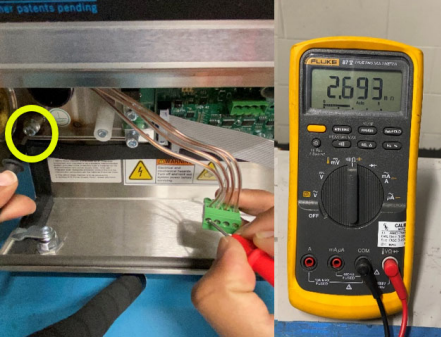
Instruction	Graphic	Desired Result/Action
1. Turn the SuperTrak power supply power OFF.		
2. Detach the first green terminal block plug from the coil driver board and use a multimeter to check the resistance between the 1st and 2nd pin (first and second as counted from the left).		A resistance range of 0.1-0.6 $\Omega$ (Ohms) indicates that the coil is functioning properly.
3. Check the resistance between the 3rd and 4th pin.		A resistance range of 0.1-0.6 $\Omega$ indicates that the coil is functioning properly.
4. Check the resistance between the 1st and 4th pin.		This should be open or no connection. You may see varying resistance measured on the multimeter, but it should not settle on a specific measurement. If the multimeter does settle on a resistance amount, it means the coils are mis-wired and must be wired correctly to avoid blowing fuses.

<p>5. Measure the resistance between the motor body and the 1st pin on the terminal block plug.</p>		<p>The resistance should show higher than 0.6 Ω . If the resistance is 0.6 or lower, the coil is shorted. The coils are not serviceable , so the motor may need to be returned for repair.</p>
<p>6. Measure the resistance between the motor body and the 3rd pin on the terminal block plug.</p>		<p>Same as prior step: the resistance should show higher than 0.6 Ω . If the resistance is 0.6 or lower, the coil is shorted. The coils are not serviceable , so the motor may need to be returned for repair.</p>
<p>7. Repeat the steps above for all terminal block plugs in the section’s coil driver board.</p>		

## Pallet Faults

Fault	Resolution
Pallet following error	<ul style="list-style-type: none"> <li>• Check for mechanical or other interference with the pallet (for example, a jammed part). The fault indicates the location.</li> <li>• Inspect the pallet. See <a href="#">Inspect a Pallet</a> on page 195.</li> <li>• Verify that a coil fuse is not blown. If a pallet travels across a coil with a blown fuse, pallet momentum is usually adequate to allow acceptable control. However, if the pallet attempts to stop in the vicinity of this coil, it will have poor control, which will trigger a following error. See <a href="#">Replace a Coil Fuse</a> on page 174.</li> <li>• Check for a damaged upper v-rail, flat wear strip, or motor cover label.</li> </ul>
Pallet lost position	<ul style="list-style-type: none"> <li>• Check the encoder strip, to make sure that it is not damaged. See <a href="#">Inspect a Pallet</a> on page 195.</li> <li>• Check encoder calibration. See the TrakMaster built-in help for the calibration procedure.</li> <li>• Verify the encoder functionality. View the TrakMaster Encoder screen, to make sure the encoders are functioning.</li> </ul>
Pallets stop at section joints	<p>Verify that the rails are correctly aligned. If the rails of sections are not correctly aligned, pallets may not be able to move across the joints of low power sections. Make sure that magnetic shunts are installed in the correct orientation. See <a href="#">Install a Wedge Adjust</a> on page 100.</p>

# Test Straight Section or Curved Section Hardware



TrakMaster software is required for most of the straight section or curved section hardware testing procedures.

This section describes how to test the functionality of straight section or curved section hardware components.

## Test Encoder Functionality

1. Open TrakMaster.
2. In the left pane, click **Diagnostic > Encoders**.
3. If required, click the **Status** tab.
4. At the top of the screen, click ◀ or ▶ to select the required **Section** to test.

5. By hand, slowly move a pallet across the section you selected in step 4. As you move the pallet, watch the grey Xs on the left side of the screen. The Xs, beginning with **Encoder 0** or **15** depending on the direction the pallet is moving, should change to a yellow star and then to a green checkmark. As the pallet continues to travel across the section the green checkmark may or may not change back to a yellow star and then back to a grey X.

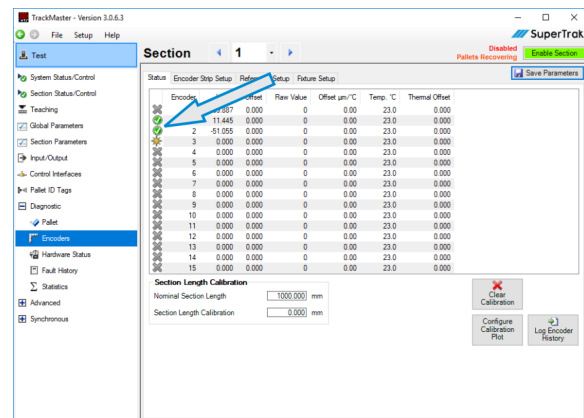

The encoders pass if all the grey Xs sequentially change to a green checkmark.

## Test the Coil Functionality

1. Remove all pallets from the straight section or 180 deg. section to be tested.
2. Turn the SuperTrak power supply power ON.  
This is generally done by turning the system power ON when the safety circuit is closed.
3. Open TrakMaster.
4. In the left pane, click **Advanced > Coil Control**.
5. Click **Check All**.

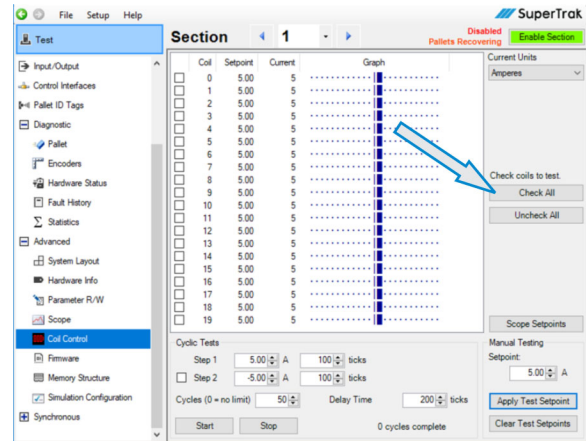

6. Verify that the section is disabled and that there are no active faults or warnings.  
The top right of the screen displays **Disabled** when faults or warnings exist. If required, open the Section Status/Control screen to clear any faults or warnings.
7. Verify that the **Setpoint** is set to 5.00 A.



8. Click **Apply Test Setpoint**.

To pass, each **Coil** should display a **Current** of  $5.00 \pm 0.5$

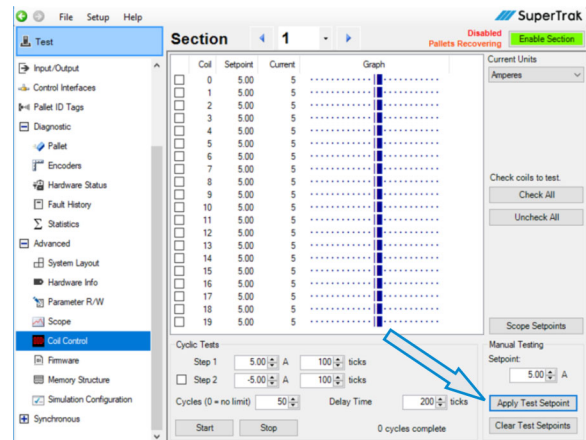

9. Click **Clear Test Setpoints**.

10. Enter a value of -5.00 into the **Setpoint** field.

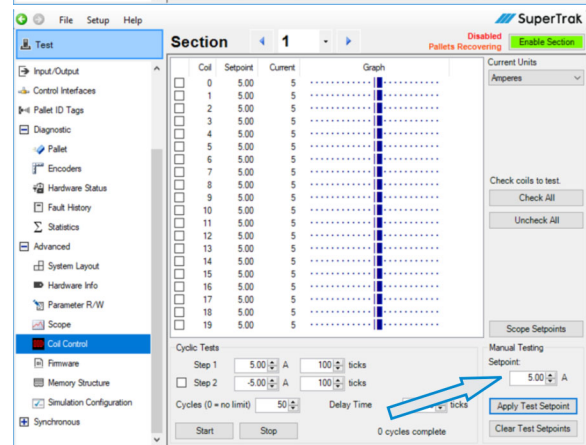

11. Click **Apply Test Setpoint**.

To pass, each **Coil** should display a **Current** of  $-5.00 \pm 0.5$  for standard sections or  $1.00 \pm 0.5$  for collaborative sections.. This verifies that the current control works in both directions.

12. Click **Clear Test Setpoints**.

## Test for a Reversed Polarity Coil

If a coil is connected backward it will have reversed polarity. There are two (2) methods to test for reversed polarity in a coil:

- [Test with the PLC in MANUAL Mode](#) on page 262  
If this option is available, it is easier and quicker to use this test.
- [Test Manually with TrakMaster](#) on page 263

### Test with the PLC in MANUAL Mode

Use this test if you can place the PLC in MANUAL mode and step the system through process steps; otherwise, see [Test Manually with TrakMaster](#) on page 263.

1. Open the Global Parameters window in TrakMaster
2. Note the value of the **Maximum Velocity** parameter, so that you can change the value back to this after the test.

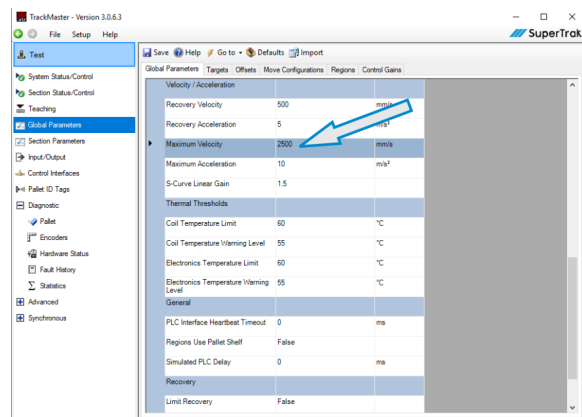

3. Set the **Maximum Velocity** parameter to 50 mm/s.
4. Manually step the PLC until a pallet fully-travels the length of the straight section or 180 deg. section to be tested.  
  
The hardware passes if the pallet fully-travels the section without producing an **Excessive pallet following error** fault.
5. Set the **Maximum Velocity** parameter back to the value that was noted in step 2.

## Test Manually with TrakMaster

**NOTICE**

Before starting this test, manually block any system tooling that could interfere with pallet motion. Failure to do so, could result in system damage.

During this test, a pallet is manually commanded across the straight section or 180 deg. section being tested and across the sections on either side of the straight section or 180 deg. section being tested.

1. Prepare the system and SuperTrak pallets:
  - a. Verify that no system tooling can interfere with pallet motion. If required, block the system tooling out of the way.
  - b. Remove all pallets from the straight section or 180 deg. section to be tested and the sections on each side of it.
  - c. Position a pallet directly on the right or left side of the section to be tested.

2. Open TrakMaster.

3. In the left pane, click **Diagnostic > Pallet**.

4. At the top of the screen, click ◀ or ▶ to select the **Section** that contains the pallet to use for the test.

The selected pallet graphic has a red outline.

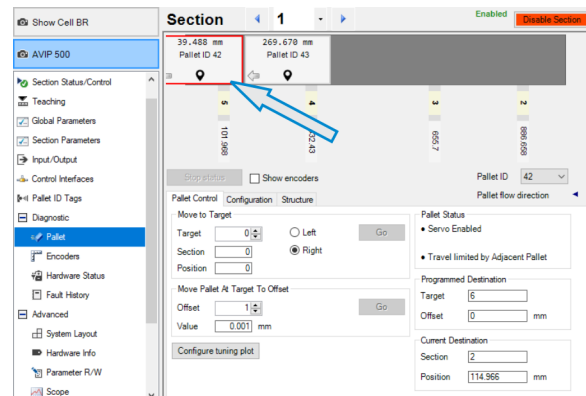

5. Click the **Configuration** tab.

6. Note the value of the **Velocity** parameter, so that you can change the value back to this after the test.

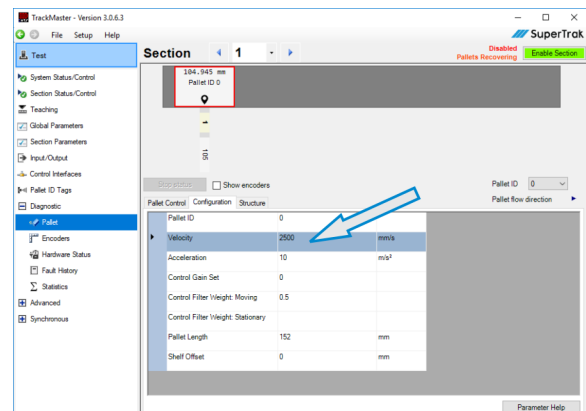

7. Set the **Velocity** parameter to 50 mm/s.
8. Click the **Pallet Control** tab.
9. Under **Move to Target**, select a **Target** that is past the section to be tested and in the direction that will cause the pallet to travel over the section to be tested.

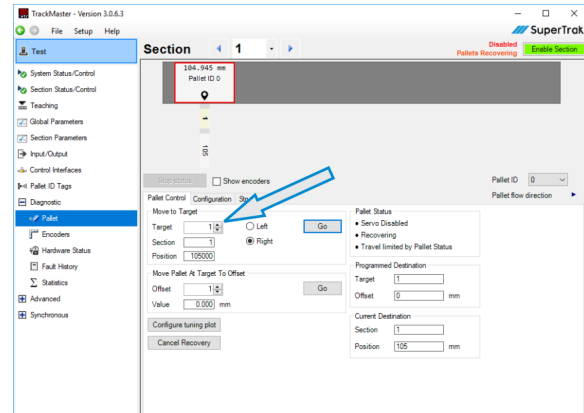

10. Select the correct pallet direction (**Left** or **Right**), and then click **Go**.
11. With the SuperTrak power supply power ON, click **Diagnostic > Pallet**, and then click **Enable Section** for the section being tested and the sections on each side of it.  
  
Do not enable power to any other sections because this may cause all the SuperTrak pallets to move around the system.
12. In the left pane, click **System Status/Control**, and then click **Disable Zone**.  
  
The section passes if the pallet fully travels over the section without producing an **Excessive Follow Error** fault.
13. Click the **Configuration** tab.
14. Set the **Velocity** parameter value to the value noted in step 6.

## Test the Status of the Hardware

1. Open TrakMaster.
2. In the left pane, click **Diagnostic > Hardware Status**.
3. Verify that the **State** of all motor temperature sensors is set to **Monitored**.
4. Verify that the **Value** for:

- Motor temperature sensors are reasonable. This value varies depending on the state of the system.

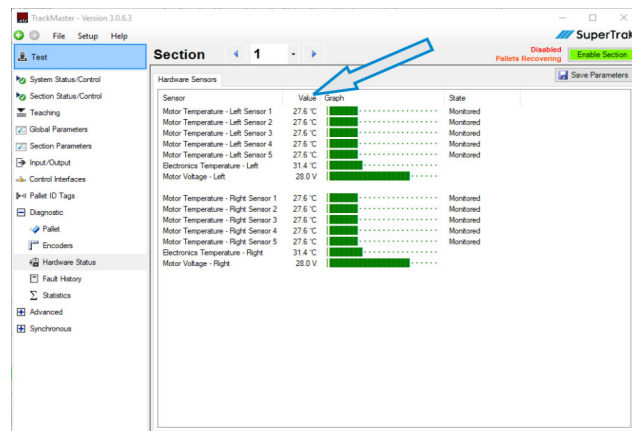

*NOTE: All sections have two (2) coil driver boards with the exception of the 180 deg. (800 mm) section which has three (3). Each coil driver board has five (5) thermistor connections; straight sections and 90 deg. sections have ten (10) thermistors while 180 deg. (800mm) sections have fifteen (15).*

*A 180 deg. (500mm) section has only six (6) thermistor locations, and thus only uses three (3) connections per coil driver board. As a result thermistors 2 and 4 (Left and Right) are set to "Ignored" by default in TrakMaster.*

- Electronics temperatures are within a reasonable range (25-50°C [77-122°F]).
- Motor voltages are representative of the current SuperTrak power supply power state (ON or OFF), and are within a reasonable range (27-29V).

## Test the Rail System

1. Inspect both the flat and upper v-rail for any damage or debris build-up.
2. Inspect the flat rail, to verify that the wear strip is correctly seated in the groove of the track structure.
3. Slowly, manually move a pallet fully across a straight or curved section. As you move the pallet, feel for any resistance in pallet motion.
4. Verify that the alignment of the upper v-rail is correct between every straight section and between the straight sections and curved sections.
5. Verify that the alignment of the flat rail is correct between every straight section and between the straight sections and curved sections.

## Test a Magnetic Shunt

1. Manually move a pallet over straight section and curved section joints. Feel for an excessive amount of resistance (magnetic bump).
2. If necessary repeat this in several locations to obtain a baseline of what the magnetic bump should feel like.

## Diagnostic Lights

This section provides information about the indicator lights on the SuperTrak conveyance platform hardware.

### Controller Indicator Lights

The controller has four (4) indicator lights: Power, HDD, Link, and Run.

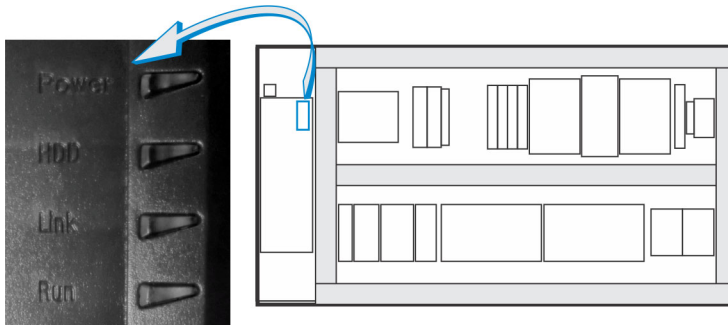

The following table summarizes the indicator light behavior.

See the *APC910 User's Manual* for additional information.

Indicator	Color	Light State	Normal	A Problem May Exist
Power	Green	Solid	✓	
		Blinking		A controller hardware problem exists. Contact your vendor for assistance.
	Red	Solid		The controller power is OFF. Press the power button to turn it ON.
		Blinking		A controller hardware problem exists. Contact your vendor for assistance.
	Red/ Green	Blinking		
HDD	Yellow	Occasional Blink	✓	
Link	Yellow	Solid	Normal when an SDL display is connected.	
		Blinking		SDL display power was interrupted. Check the cables.
		Off	Normal when an SDL display is not connected.	

Indicator	Color	Light State	Normal	A Problem May Exist
Run	Green	Solid	✓	
		Blinking	✓	The controller startup sequence is not yet complete. Wait several minutes.
	Red	Solid		A controller software problem exists. Contact your vendor for assistance.
		Blinking		

## Gateway Board (ACB3040) Indicator Lights



The gateway board image may not reflect the latest version of the gateway board.

The gateway board has thirteen (13) indicator lights.

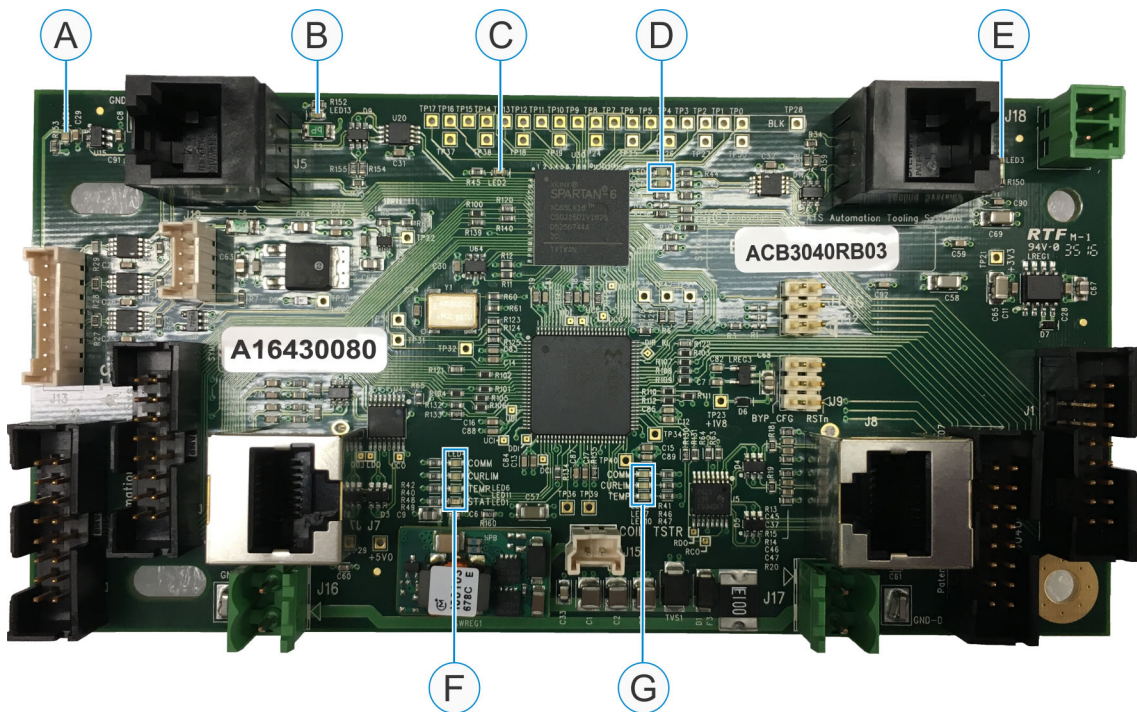

ID	LED #	Color	Light State	Normal	A Problem May Exist
A	14	Red	ON		Power to the IR reader is disabled because of excessive current draw. A short-circuit may exist in the IR reader or in the IR reader cable.
			OFF	✓	



ID	LED #	Color	Light State	Normal	A Problem May Exist
B	13	Red	ON		Power is disabled due to excessive current draw, A short-circuit exists in the encoder board or in the encoder board cable.
			OFF	✓	
C	2	Green	Any	N/A	A software diagnostic LED. This indicator is for development purposes only.
D	8	Red	Any	N/A	Software diagnostic LEDs. These indicators are for development purposes only.
D	9	Yellow			
E	3	Red	ON		Power is disabled due to excessive current draw, A short-circuit exists in the encoder board or in the encoder board cable.
			OFF	✓	
F	1 (STAT) <sup>a</sup>	Green	ON	✓	
			Blinking very slow		The network is not configured.
			Blinking slow		The FPGA is not configured.
			Blinking fast		The FPGA is ready but inactive.
			OFF		Power is OFF.
F and G	4 (COMM) <sup>b</sup> and 5 (COMM) <sup>b</sup>	Orange or Blue	ON		Gateway board communication does not exist with the controller.
			Blinking fast		The coil current set points are not received.
			OFF	✓	
F and G	6 (CURLIM) <sup>c</sup> and 7 (CURLIM) <sup>c</sup>	Red	Blinking fast	✓ (normal if the motor power is OFF)	The coil driver board is deactivated.
			OFF	✓	
F	11 (TEMP) <sup>d</sup>	Yellow	ON	✓	The gateway board is configured on the left network.
			OFF	✓	The gateway board is configured on the right network.

ID	LED #	Color	Light State	Normal	A Problem May Exist
G	10 (TEMP) <sup>d</sup>	Yellow	ON	✓	The gateway board is the last in the network.
			OFF	✓	The gateway board is not the last in the network.

- a. STAT stands for status.
- b. COMM stands for communication.
- c. CURLIM stands for current limit. Note that the text does not correlate to the LED function.
- d. TEMP stands for temperature. Note that the text may not correlate to the LED function. Gateway boards that were manufactured before mid-2016 and have not received a CPLD firmware update use the yellow LEDs as follows: ON=defective thermistor detected, blinking fast=the operating temperature limit is exceeded, OFF=the motor temperature is within operating range.

## Coil Driver Board (ACB3000) Indicator Lights

The coil drive board has two (2) indicator lights: one green, and one red.

Indicator Light	Light State	Normal	A Problem May Exist
Green	ON	✓ (power is ON)	
	OFF		The power is OFF.
Red	ON		The A/D CPLD is not programmed. Contact your vendor for assistance.
	OFF	✓	

# System Specifications

This section provides SuperTrak conveyance platform system specifications. Information in this section is for general reference and may be updated without notice. Be sure you are using the most current version of this user manual.

For details on the system's individual components, see [Appendix C: Component Data Sheets](#) on page 299.

## Performance

The SuperTrak conveyance platform is designed to meet the following optimal performance<sup>a</sup>:

Performance Description	Value
Maximum speed	4 m/s (13.1 ft./s)
Acceleration	1g with 10 kg (22 lb) payload 4g with 1 kg (2.2 lb) payload
Payload	10+ kg (22+ lb) per pallet <sup>1</sup>
Stop repeatability - straight section	± 0.01 mm (0.00039 in.)
Stop repeatability - curved sections	± 0.025 mm (0.001 in.)
Communication	EtherNet/IP, PROFINET, POWERLINK, and EtherCAT <sup>2</sup>
Number of supported pallets	As many as can physically fit on the track length
Process on curve	Yes, full control
Pallet options	Standard configuration with 2 or 3 magnet array options
Collision avoidance	Built in
Power consumption	10W/section, 150-275W/pallet <sup>3</sup>
Servo update rate	800 µs typical

1. Higher payloads are possible. Contact ATS with application details.
2. Other protocols are possible. Contact ATS if other protocols are required.
3. Power consumption varies depending on the aggressiveness of the application: it may be less with less demanding requirements or more with more demanding requirements.

<sup>a</sup>Performance does not include supplied product defects, operator error, operator training, or failure of services.

See [Appendix C: Component Data Sheets](#) on page 299 for additional information about individual system components.

## Environment Conditions

State	Specification	Straight Section or Curved Section Value	Power Supply Value
Operation	Temperature (ambient)	5°C (41°F) to 55°C (131°F)	-20°C (-4°F) to 71°C (159.8°F)
	Humidity (relative)	5% to 85% non-condensing	20% to 90%
Storage	Temperature (ambient)	-25°C (-13°F) to 55°C (131°F)	-20°C (-4°F) to 75°C (167°F)
	Humidity (relative)	5% to 95% non-condensing	20% to 90%
Transport	Temperature (ambient)	-25°C (-13°F) to 70°C (158°F)	-20°C (-4°F) to 75°C (167°F)
	Humidity (relative)	Max.95% at 40°C (104°F)	20% to 90%

## Environmental Limits

Specification	Power Supply Value
Mains configuration	1 phase x 200-240VAC 50/60 Hz Grounding: TN
Degree of contamination	Pollution degree 2 environments
Over-voltage capacity	II
IP protection	IP20
NEMA protection	NEMA type 1
Maximum installation altitude	2000 m (6561.6 ft.)

## Installation Requirements

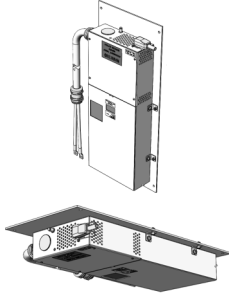
Service	Specification	Value
Power supply (high power)	Input rating	1 phase x 200-240VAC 50/60 Hz
	Output rating	28VDC 1500W
	Fuses/circuit breaker	10 A UL489 breaker Type CC fuses, or type J fuses
	Terminal connection cross-section	Connect as per local requirements for 10A
	Permitted mounting orientations	<ul style="list-style-type: none"> <li>Vertical with the air filter down.</li> <li>Horizontal with the access panel facing down.</li> <li>Any orientation if mounted inside a sufficient enclosure with adequate cooling.</li> </ul> 
Power supply (low power)	Input rating	1 phase x 200 to 240VAC, 50/60 Hz
	Output rating	15VDC, 320W
	Fuses/circuit breaker	10A class CC or J
	Terminal connection cross-section	Connect as per local requirements for 10A
	Permitted mounting orientations	Same as 28V supply
Straight section	Input rating	28VDC 100A peak
	Output rating	Force of up to 150N/pallet
	Fuses/circuit breaker	50A fuses
	Terminal connection cross-section	16 mm <sup>2</sup> cables terminated with a wire lug
	Permitted mounting orientations	Horizontal upright, or vertical over/under

<b>Service</b>	<b>Specification</b>	<b>Value</b>
180 deg. section (500 mm)	Input rating	28VDC 100A peak
	Output rating	Force of up to 150N/pallet
	Fuses/circuit breaker	50A fuses
	Terminal connection cross-section	16 mm <sup>2</sup> cables terminated with a wire lug
	Permitted mounting orientations	Horizontal upright, or vertical over/under
180 deg. section (800 mm)	Input rating	28VDC 150A peak
	Output rating	Force of up to 150N/pallet
	Fuses/circuit breaker	50A fuses
	Terminal connection cross-section	16 mm <sup>2</sup> cables terminated with a wire lug
	Permitted mounting orientations	Horizontal upright
90 deg. section	Input rating	28VDC 100A peak
	Output rating	Force of up to 150N/pallet
	Fuses/circuit breaker	50A fuses
	Terminal connection cross-section	16 mm <sup>2</sup> cables terminated with a wire lug
	Permitted mounting orientations	Horizontal upright

## Electrical Services

Service	Specification	Value
Control panel	Line voltage	208Y120VAC+PE Or 400Y230VAC+PE
	Frequency	50/60 Hz
	Phases	3 ph, 5-wire
	Short circuit current rating	5kA
	Largest load	20A
	Control voltage	24VDC (digital power supplied from the control panel) 28VDC (motor power supplied from the power supplies)
	Full load amps	36A
UPS (located inside the control panel)	Line voltage	24VDC
	Frequency	50/60 Hz
	Current rating	15A

## Electromagnetic Compatibility (EMC) Requirements for High-Frequency Emissions

The following table provides the high-frequency emissions in accordance with EN 61000-6-4:

Emission	Test Accordance	Class	Emission
Conducted emissions	IEC 55011	Class A Group 2	150 kHz - 30 MHz
Radiated emissions	IEC 55011	Class A Group 2	150 kHz - 1000 MHz

## Electromagnetic Compatibility (EMC) Requirements for Immunity to Disturbances

The following table provides high-frequency disturbance limits in accordance with EN 61000-6-2:

Disturbance Type	Test Accordance	Description	Limit Requirement	PC <sup>a</sup>
Electrostatic discharge	EN 61000-4-2	Contact discharge to powder-coated and bare metal housing parts.	4kV	B
		Discharge through the air to plastic housing parts.	8kV	B
Electrostatic fields	EN 61000-4-3	Housing, completely wired.	10V/m, 51 MHz, 144 MHz, 222 MHz, 431 MHz, 2.4 GHz Radiated field as produced by portable radios modulation.	A
Burst	EN 61000-4-4	AC mains	±2kV, 1 min, direct coupling.	B
		I/O ports	N/A	B
Surge	EN 61000-4-5	Power connection	±2kV, CM (L-Gnd), ±1kV, DM (L-L), N/A on I/O Ports	B
High-frequency conducted disturbances	EN 61000-4-6	Power connection	0.15 - 250 MHz, 10 Vrms, 80% amplitude modulation at 1 kHz	A
		I/O ports	N/A	-

a. Performance criteria (PC) descriptions are as follows:

A - The system will continue to operate as intended without operator intervention. No degradation of performance or loss of function is allowed below a performance level specified by Automation Tooling Systems when the system is used as intended. The performance level may be replaced by a permissible loss of performance. If the minimum performance level or the permissible performance loss is not specified by Automation Tooling Systems, then either of these may be derived from the product description and documentation and by what the user may reasonably expect from the system if used as intended.

Preprogrammed move of pallets showing speeding up, sudden stop in predetermined position, short moves back-and-forth and speeding up again, are simulated to show all possible scenarios of the pallet moves. No stopping of pallets, no errors on the control screen, and no alarms are allowed during the application of the test voltage.

B - After the test, the system will continue to operate as intended without operator intervention. No degradation of performance or loss of function is allowed, after the application of the phenomena below a performance level specified by Automation Tooling Systems, when the system is used as intended. The performance level may be replaced by a permissible loss of performance. During the test, degradation of performance is allowed. However, no change of operating state or stored data is allowed to persist after the test. If the minimum performance level (of the permissible performance loss) is not specified by Automation Tooling Systems, then either of these may be derived from the product description and documentation and by what the user may reasonably expect from the system if used as intended.



# Glossary

This section contains an alphabetized list of terms and acronyms that may be used in this document.

Term	Definition
ATS	Automation Tooling Systems, Inc.
Bus board	A capacitor bank that filters out spikes or ripples in the electrical supply to provide smooth DC voltage. A bus board is mounted behind each linear motor.
Cell	Two (2) or more stations that are grouped together. Typically, a cell can function independently of other cells. In some cases, cells are connected by a global emergency stop.
Component	Typically, the smallest and most detailed level of the SuperTrak conveyance platform. For example; a single piece of tooling, a sensor, or a cylinder.
Control interface	A protocol that provides isolated bi-directional communication from the SuperTrak conveyance platform controller to local cell controllers. This protocol is executed over one of the supported fieldbus network.
Cycle	The complete sequence of steps that a device performs to complete a task.
Cycle time	The time a device takes to complete a sequence of operations once.
Device	Two (2) or more components that are grouped together to complete a single function. A device can be controlled by software to move through a sequence of steps. For example; a conveyor, or lift tooling.
Disable	Prevent a device from operating through software or by removing power.
Disconnect	To interrupt or terminate a connection.
Enable	Allow a device to operate through software or by connecting power.
Encoder	A position sensor that continuously monitors pallet positions.

Term	Definition
Encoder assembly	Bracket that contains the printed circuit board (PCB) with the encoder readers installed on the SuperTrak linear motor sections. Reads the encoder strips in the shuttle encoder assembly which is used by the SuperTrak controller to determine the position of shuttles.
Encoder strip	A magnetic strip located on the pallet that is read by the encoder assembly for position feedback.
E-turn	References a 180 deg. section (500 mm).
Frame	A metal base that can be used to set up the SuperTrak conveyance platform system off the floor. SuperTrak GEN3 Frames are designed to work with SuperTrak conveyance platforms.
Gateway network	An ATS proprietary network, implemented using standard Ethernet cables; however, it is not Ethernet and should not be connected to Ethernet devices. It connects an array of gateway boards to the controller.
GEN3	Third generation.
Guarding	A protective barrier surrounding automated equipment to prevent access to moving devices and to guard users from potentially hazardous conditions.
ISO	International Organization for Standardization ISO is an international organization composed of national standards bodies from over 75 countries.
Lockout	The placement of a locking device (such as a padlock) on an energy isolating device, in accordance with an established procedure, to make sure that the energy isolating device and the equipment being controlled cannot be operated until the locking device is removed. Used in combination with tagout.
Master pallet	A SuperTrak pallet that is stored in a safe place and is only installed on the SuperTrak to verify nominal settings.
Motor assembly	References the hardware that powers the SuperTrak conveyance platform. The motor is mounted in an extruded outer frame that protects and encloses all the working elements of a section. It assembly incorporates the magnetic laminations, coils, drive electronics and controller for a track section.
Pallet	A movable base on which parts can be placed. A pallet can be partitioned to hold more than one part. A pallet may also be referred to as a shuttle.

<b>Term</b>	<b>Definition</b>
Pallet encoder strip assembly	Assembly containing magnetic encoder strips and installed on the shuttle assembly. The encoder assembly reads the encoder strips in the shuttle encoder strip assembly for position feedback.
PCB	Printed circuit board Mechanically supports and electrically connects electronic components using conductive tracks, pads and other features etched from copper sheets laminated onto a non-conductive substrate.
PLC	Programmable Logic Controller An electronic processor that contains the programmable code for controlling system operation, device operating sequences, fault recovery, and data processing.
Reference pallet	A SuperTrak pallet that is installed on the SuperTrak conveyance platform and is used as a reference. It can be a specific production pallet, or a few different pallets can be sampled and the pallet in the middle of the range can be used.
Shuttle	A pallet may also be referred to as a shuttle.
Stand	An adjustable metal apparatus that mounts a section to the SuperTrak GEN3 frame. Stands may be standard height or low profile.
Station	Two (2) or more devices that work together to complete a task. For example; a pallet stop on a conveyor and all the devices responsible for working on the contents of the pallet.
System	References the automation machine that the SuperTrak conveyance platform is integrated with.
Tagout	The placement of a durable tag on an energy isolating device, in accordance with established procedure, to identify the person who placed a lock on the device. Equipment being controlled by the energy isolating device must not be operated until the lock and tag have been removed. Used in combination with lockout.
Target	A location on the SuperTrak conveyance platform that can be set as a pallet destination. A SuperTrak conveyance platform can have up to 255 configured targets, each located anywhere on the system.
Thermistor (motor thermistor)	A motor thermistor is a temperature sensor that is used to monitor the temperature of the linear motor.

Term	Definition
Track section	A 1 m (3.28 ft.) long piece of conveyor track that can be joined with other sections of conveyor to produce a length of SuperTrak conveyance platform. The sections typically share a common power supply or multiple power supplies, and communicate with each other over a high speed data network.
TrakMaster	Software that provides configuration, programming, diagnostics and control over a supervisory data network. TrakMaster communicates over Ethernet. TrakMaster is not required to operate SuperTrak conveyance platform; however, it is useful for troubleshooting and configuring the device.
UPS	Uninterruptible power supply or uninterruptible power source An electrical device that provides electrical power to a device when the main source of electrical power is turned OFF.
Wide e-turn	References a 180 deg section (800 mm).

# SuperTrak Conveyance Platform Service

This section describes how to contact ATS Service Support for customer assistance.

## Contact ATS

Please contact ATS for assistance, questions or comments regarding the operation or maintenance of your equipment.

ATS Automation Tooling Systems, Inc

730 Fountain Street North

Cambridge, ON, N3H 4R7, Canada

Tel: 519-653-6500

Fax: 519-650-6538

Email: [info@atsautomation.com](mailto:info@atsautomation.com)

[www.atsautomation.com](http://www.atsautomation.com)

Regular business hours are 8:30 am to 5:00 pm EST, Monday through Friday.  
Emergency support hours are 5:30 pm to 8:00 am EST, weekends and holidays.

Emergency Support Tel: 519-653-3060

## Return a Part to ATS for Warranty

If your spare parts inventory does not contain a replacement part for a failed SuperTrak conveyance platform part, you can purchase a replacement part from ATS.

1. Contact ATS Post Automation Support with the following information:
  - Project number  
See the electrical panel, or front cover of this manual for the project number.
  - Part number
  - Part description
  - A brief description of the failure.
2. ATS provides you with a service return material authorization (SRMA) number.
3. Courier your defective part to ATS. A tracking number is recommended. Make sure the SRMA number is on the outside of the package.
4. When ATS receives the defective part, one (1) of the following is done:
  - For parts manufactured by ATS, ATS directly validates the warranty by repairing or replacing the part. Proceed to step 7.
  - For purchased parts (for example; motors, or amplifiers), ATS sends the defective part to the original manufacturer. The original manufacturer validates the warranty and repairs or replaces the part at their discretion.

Be aware that some manufacturers require a purchase order (PO) to test returned parts. If a PO is required, ATS will contact you for a PO before additional action is taken.

5. Depending on the original manufacturer response, ATS contacts you with a list of options:
  - The defective part is repaired or replaced under warranty. Freight is the responsibility of the customer.
  - The defective part is not covered under warranty, but it can be repaired with a PO. ATS provides a quote for part repair.
  - The defective part is not covered under warranty, and it can not be repaired. ATS provides a quote for part replacement and discards the defective part unless otherwise directed.
6. When ATS receives the replacement part from the manufacturer, ATS sends the replacement part back to the original sender unless otherwise directed.
7. ATS closes the SRMA.

## Request Service from ATS

Contact ATS Post Automation Support if service is required on your SuperTrak conveyance platform. Please have the following information available when you call:

- Company name
- Contact name
- Contact number
- Project number

See the electrical panel, or front cover of this manual for the project number.

- Technical description of the problem
- Purchase order number

This page is intentionally blank.



# Appendix A: Hardware Torque Specifications

The following table provides the hardware torque specifications to use during the installation of the SuperTrak conveyance platform.

Location Description	Size	Type	Finish	Class	DIN	Qty per	Torque (Nm)
Top connection plate	M10-1.5x40	SHCS	Zinc Plated	12.9	912	8	80
Side connection plate	M10-1.5x40	SHCS	Zinc Plated	12.9	912	12	80
Straight section mount plate	M10-1.5x40	SHCS	Zinc Plated	12.9	912	4	80
Curved section mount plates	M10-1.5x40	SHCS	Zinc Plated	12.9	912	4	80
	M10	O/S Washer	Zinc Plated		7349	4	
	M8-1.25x40	SHCS	Zinc Plated	12.9	912	8	40
	M8	O/S Washer	Zinc Plated		7349	8	
Straight section stand to mount	M8-1.25x40	SHCS	Zinc Plated	12.9	912	8	40
	M8	O/S Washer	Zinc Plated		7349	8	
Straight Section Stand to Motor	M6-1.0x45	SHCS	Zinc Plated	12.9	912	8	16
	M6	O/S Washer	Zinc Plated		7349	8	
Curved section stand	M8-1.25x75	SHCS	Zinc Plated	12.9	912	3	40
	M8	Lock Washer	Zinc Plated		127	3	
Joint plate	M6-1.0x35	SHCS	Zinc Plated	12.9	912	8	16
	M6	Fender Washer	Zinc Plated		9021	8	
Power supply mount	M5-0.8x16	SHCS	Zinc Plated	12.9	912	4	10
	M5	Flat Washer	Zinc Plated		125	4	
	M5	Lock Washer	Zinc Plated		127	4	

Location Description	Size	Type	Finish	Class	DIN	Qty per	Torque (Nm)
180 deg. (500 mm) section top cover	M5-0.8x10	SHCS	Zinc Plated	12.9	912	10	10
Encoder	M3-0.5x8	SHCS	Zinc Plated	12.9	912	10	2
Upper v-rail 180 deg. (500 mm)	M6-1.0x14	SHCS	Zinc Plated	12.9	912	11	16
Upper v-rail 180 deg. (800 mm) and 90 deg.	M8-1.25x16	SHCS	Zinc Plated	12.9	912	3	40
	M8	Lock Washer	Zinc Plated		127	3	
Interconnect 24VDC motor and cable	M5-0.8x14	SHCS	Zinc Plated	12.9	912	2	9
	M5	Int. Tooth Washer	Zinc Plated		6797	2	
	M5	Flat Washer	Zinc Plated		125	2	
Interconnect com cable	M6-1.0x14	SHCS	Zinc Plated	12.9	912	2	11
	M6	Int. Tooth Washer	Zinc Plated		6797	2	
	M6	Flat Washer	Zinc Plated		125	2	
Interconnect to cabinet ground	M6-1.0x14	SHCS	Zinc Plated	12.9	912	2	11
	M6	Int. Tooth Washer	Zinc Plated		6797	2	
	M6	Flat Washer	Zinc Plated		125	2	
50A fuse to coil driver PCB	M5-0.8x8	SHCS	Zinc Plated	12.9	912	1	2.7
	M5	Int. Tooth Washer	Zinc Plated		6797	1	
	M5	Flat Washer	Zinc Plated		125	1	
Coil driver board to bus bar	M4-0.7x12	SHCS	Zinc Plated	12.9	912	13	2
	M4	Int. Tooth Washer	Zinc Plated		6797	13	
	M4-0.7x12	Phillips head nylon screw	None		7985	1	

Location Description	Size	Type	Finish	Class	DIN	Qty per	Torque (Nm)
Gateway board to bus bar	M4-0.7x16	SHCS	Zinc Plated	12.9	912	4	2
	M4	Int. Tooth Washer	Zinc Plated		6797	4	
Pallet - front cover	M5-0.8x8	BHSCS	Zinc Plated	10.9	7380	4	5.8
Pallet - shoulder screw	SS 8MMX10MM	Shoulder Screw - 8MM DIA, 10MM LONG, M6X1.0 Thread	Black oxide	12.9	7379	2	10
Pallet - 2-magnet	M6-1.0x20	SHCS	Zinc Plated	12.9	912	2	16
Pallet - 3-magnet	M4-0.7x20	SHCS	Zinc Plated	12.9	912	4	4.5
Pallet - anti-tip blocks	M4-0.7x10	SHCS	Zinc Plated	12.9	912	4	4.5
Pallet - encoder strip	M5-0.8x12	LSHCS	Zinc Plated	8.8	7984	2	5.4
Pallet - anti-static brush	M3-0.5x6	BHSCS	Zinc Plated	10.9	7380	4	1.3
Pallet - lubricator	M3-0.5x14	SHCS	Zinc Plated	12.9	912	2	2
Wear strip locator	M3-0.5x8	SHCS	Zinc Plated	12.9	912	1	2

This page is intentionally blank.

# Appendix B: Spare Parts











Be aware that the graphics in this section are not to scale.

---

This section provides the recommended spare parts information for the SuperTrak conveyance platform.

## Cables and Wires

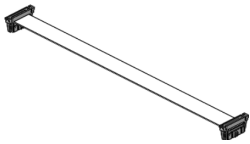
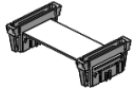

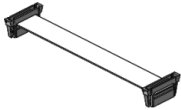
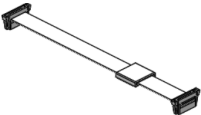
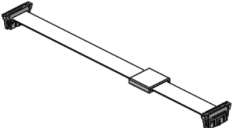
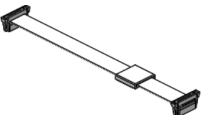

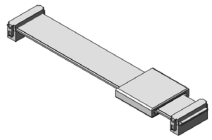
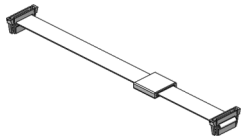

Description	Graphic	Part Number	Where Used	Rec. Qty <sup>a</sup>	Replacement Frequency <sup>b</sup>	Critical <sup>c</sup>
Encoder cable		SP-1061547	•All Sections	1	Very Low	Yes
Encoder cable - 548mm		SP-1061547	<ul style="list-style-type: none"> <li>•Straight Section FME</li> <li>•180 Degree Section 500mm</li> <li>•180 Degree Section 800mm</li> <li>•90 Degree Section</li> </ul>	1	Very Low	Yes
Encoder cable - 700mm		SP-125420384	•Straight Section RME	1	Very Low	Yes
Thermistor - 300mm		SP-1061479	<ul style="list-style-type: none"> <li>•Straight Section FME</li> <li>•180 Degree Section 500mm</li> <li>•180 Degree Section 800mm</li> <li>•90 Degree Section</li> </ul>	1	Very Low	Yes
Thermistor - 1000mm		SP-125420413	•Straight Section RME	1	Very Low	Yes
Ethernet network cable		SP-3708400	•All Sections	2	Very Low	Yes





Description	Graphic	Part Number	Where Used	Rec. Qty <sup>a</sup>	Replacement Frequency <sup>b</sup>	Critical <sup>c</sup>
Ribbon cable - 298mm		SP-1060325	•Straight Section FME	1	Very Low	Yes
Ribbon cable - 57mm		SP-1060322	•Straight Section FME	1	Very Low	Yes
Ribbon cable - 32mm		SP-1060323	•Straight Section FME	1	Very Low	Yes
Ribbon cable - 152mm		SP-1060484	•180 Degree Section 500mm	1	Very Low	Yes
Ribbon cable - 241mm		SP-1060483	•180 Degree Section 500mm •180 Degree Section 800mm •90 Degree Section	1	Very Low	Yes
Ribbon cable - 273mm		SP-1060324	•Straight Section FME •180 Degree Section 500mm •180 Degree Section 800mm •90 Degree Section	1	Very Low	Yes
Ribbon cable - 110mm		SP-125312033	•180 Degree Section 800mm •90 Degree Section	1 (when applicable)	Very Low	Yes

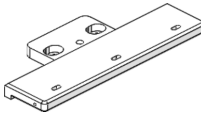

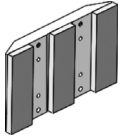

Description	Graphic	Part Number	Where Used	Rec. Qty <sup>a</sup>	Replacement Frequency <sup>b</sup>	Critical <sup>c</sup>
Ribbon cable - 130mm	 A 130mm ribbon cable with a connector at one end and a flat end at the other.	SP-125449498	•Straight Section RME	1	Very Low	Yes
Ribbon cable - 180mm	 An 180mm ribbon cable with a connector at one end and a flat end at the other.	SP-125422700	Straight Section RME	1	Very Low	Yes

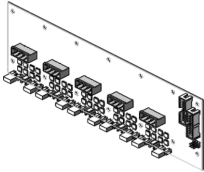
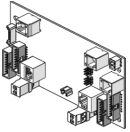



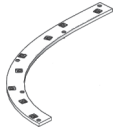

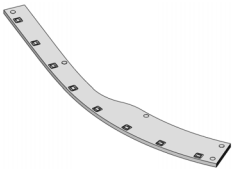
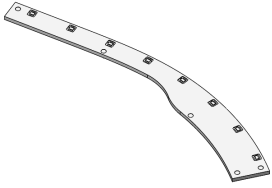

## Other Spare Parts

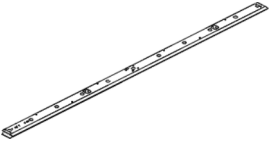
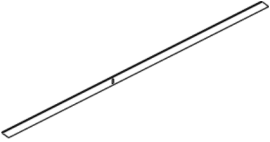
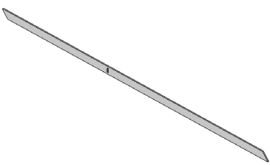
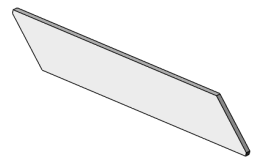
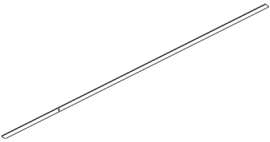

Component	Description	Graphic	Part Number	Rec. Qty <sup>a</sup>	Replacement Frequency <sup>b</sup>	Critical <sup>c</sup>
Pallet	Anti-static brush (pack of 10)		SP-25210148-PK	1+ (10-pk)	Medium	Yes
	Anti-tip block		SP-1060536	10	Low	No
	Flat wheel and bearing sub-assembly		SP-1060558	10 (individual wheels, not sets)	Medium	No
	V-wheel & bearing sub-assembly		SP-1060527	10 (individual wheels, not sets)	Medium	No
	Lubrication felt		SP-1060816	5	Medium	No
	Pallet encoder strip assembly		SP-1060543	5	Low	No
	Pallet IR tag assembly		SP-1061122	1 (if used)	Low	No
	Pallet magnet assembly - 2 magnets		SP-1060746	5 (if used)	Low	No

Component	Description	Graphic	Part Number	Rec. Qty <sup>a</sup>	Replacement Frequency <sup>b</sup>	Critical <sup>c</sup>
Pallet (continued)	Pallet magnet assembly - 3 magnets		SP-1060516	5 (if used)	Low	No
	Magnetic encoder strip viewing film (pack of 5)		SP-1837179	1	Very Low	No
	Pallet removal tool		SP-25172729	0	Very Low	No
Circuit boards	Coil driver board		SP-25211311	2+	Low	Yes
	Gateway board		SP-25211309	1+	Low	Yes
Encoder	Straight magnetic encoder assembly		SP-1060304	3	Low	Yes
	180 deg. (500mm) section RH encoder assembly		SP-1060408	1	Low	Yes

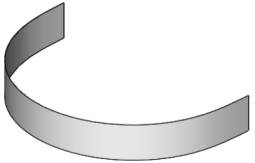
Component	Description	Graphic	Part Number	Rec. Qty <sup>a</sup>	Replacement Frequency <sup>b</sup>	Critical <sup>c</sup>
Encoder (continued)	180 deg. (500mm) section LH encoder assembly		SP-1060415	1	Low	Yes
	180 deg. (800mm) section LH encoder assembly		SP-25233511	1	Low	Yes
	180 deg. (800mm) section center encoder assembly		SP-25233529	1	Low	Yes
	180 deg. (800mm) section RH encoder assembly		SP-25234158	1	Low	Yes
	90 deg. section LH encoder assembly		SP-125526388	1	Low	Yes
	90 deg. section RH encoder assembly		SP-125526394	1	Low	Yes

Component	Description	Graphic	Part Number	Rec. Qty <sup>a</sup>	Replacement Frequency <sup>b</sup>	Critical <sup>c</sup>
Rail	Straight upper v-rail - 999.5mm		SP-1060390	0	Very Low	Yes
	Wear strip - 180 deg. (500mm) section transition		SP-1060640	1	Low	Yes
	Wear strip - 180 deg. (800mm) section transition		SP-25284328	1	Low	Yes
	Wear strip - 90 deg. section to 90 deg. section transition		SP-125595093	1	Low	Yes
	Wear strip (full length)		SP-1060669	1	Low	Yes
	Wear strip locator		SP-1060389	2	Low	Yes

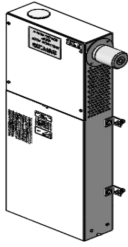
Component	Description	Graphic	Part Number	Rec. Qty <sup>a</sup>	Replacement Frequency <sup>b</sup>	Critical <sup>c</sup>
Misc.	Coil driver fuse (pack of 10)		SP-4234040-PK	1 (10-pk)	Very low	Yes
	Straight motor cover		SP-25194869	2	Low	No
	180 deg. (500mm) section motor cover		SP-25194872	1	Low	No
	180 deg. (800mm) section motor cover		SP-25237933	1	Low	No
	90 deg. section motor cover		SP-125564940	1	Low	No
	IR reader assembly (no mount)		SP-25202314	1	Very Low	Yes

Component	Description	Graphic	Part Number	Rec. Qty <sup>a</sup>	Replacement Frequency <sup>b</sup>	Critical <sup>c</sup>
Misc. (continued)	Motor power supply (no mount plate)		25270337	1+	Low	Yes
	Plastic hole plugs; size 15 (pack of 10)	N/A	SP-3708389-PK	0	Very Low	No
	Power supply 50a fuse (pack of 5)		SP-3708611-PK	1+ (5-pk)	Very Low	Yes
	Power supply exhaust filter (pack of 10)	N/A	SP-0405-0144- 101-PK	1+ (10-pk)	High	Yes
	High performance SuperTrak conveyance platform controller	N/A	SP-4598804 (Obsolete--use SP-7325131)	1 (if used)	Low	Yes
	High performance SuperTrak conveyance platform controller	N/A	SP-7325131	1 (if used)	Low	Yes

a. This is the recommended on-hand quantity for a base assembly. Increase quantities, as required, for larger SuperTrak conveyance platforms.

b. Replacement frequency definitions:

High - Replace at regular intervals.

Medium - Replace occasionally.

Low - Replace rarely.

Very Low - Replacement is not generally required.

c. Critical to the SuperTrak conveyance platform function definitions:

Yes - The SuperTrak conveyance platform will not run without this component.

No - The SuperTrak conveyance platform will run without this component.

# Appendix C: Component Data Sheets

This section provides information about SuperTrak components. Information in this section is for general reference and may be updated without notice. Be sure you are using the most current version of this user manual.

The following table summarizes the SuperTrak GEN3 components. Use the cross-references to located the data sheets for each component.

Component	Size	Option 1	Option 2	Data Sheet
Straight section <sup>a</sup>	1000 mm (39.37 in.) length <sup>a</sup>	No stands	Front-mounted electronics (FME) <sup>a</sup>	See <a href="#">Straight Section with FME Data Sheet</a> on page 314.
		Standard-height stands <sup>a</sup> 345 mm (13.58 in.)		
		Low-profile stands 158 mm (6.23 in.)	Rear-mounted electronics (RME)	See <a href="#">Straight Section with RME Data Sheet</a> on page 317.
90 deg. section	600 mm radius	Standard-height stands <sup>a</sup> 345 mm (13.58 in.)		See <a href="#">90 Deg. Section</a> on page 329.

Component	Size	Option 1	Option 2	Data Sheet
180 deg. section <sup>a</sup>	500 mm diameter <sup>a</sup> (narrow)	Standard-height stands <sup>a</sup> 345 mm (13.58 in.)		See <a href="#">180 Deg. Section (500 mm) with Standard-Height Stands Data Sheet</a> on page 320.
		Low-profile stands 158 mm (6.23 in.)		See <a href="#">180 Deg. Section (500 mm) with Low-Profile Stands Data Sheet</a> on page 323.
	800 mm diameter (wide)	Standard-height stands <sup>a</sup> 345 mm (13.58 in.)		See <a href="#">180 Deg. Section (800 mm)</a> on page 326.
Pallet	152 mm (5.98 in.) width	2 magnets <sup>a</sup>		See <a href="#">Pallet Data Sheet</a> on page 302.
		3 magnets <sup>b</sup>		
Pallet setup tools				See <a href="#">Pallet Setup Tools (Optional) Data Sheet</a> on page 341.
Pallet removal tool				See <a href="#">Pallet Removal Tool (Optional) Data Sheet</a> on page 343.
Control panel				See <a href="#">180 Deg. Section (500 mm) with Low-Profile Stands Data Sheet</a> on page 323.
Power supply				See <a href="#">Power Supply Data Sheet</a> on page 335.
IR reader				See <a href="#">IR Reader Components (Optional) Data Sheet</a> on page 339.



Component	Size	Option 1	Option 2	Data Sheet
SuperTrak GEN3 frame				See <i>SuperTrak GEN3 Frames</i> on page 344.

a. Denotes the standard deliverable.

b. The pallet pitch must be >200 mm. See the product specifications for additional information.

## Pallet Data Sheet

The pallet provides low friction transport with precise product positioning.

### Features

- Variable load is centered by the v-wheels.
- Available in four (4) options:
  - 2-magnet pallet with an IR tag.
  - 2-magnet pallet without an IR tag.
  - 3-magnet pallet with an IR tag.
  - 3-magnet pallet without an IR tag.

See [Pallet Magnet Recommendations](#) on page 309 for magnet selection guidance.

- Includes:
  - A keeper plate assembly that, when installed, shields the magnetic field of the magnets when the pallet is not installed on the SuperTrak conveyance platform.
  - Holes and recesses for mounting a custom pallet shelf.
- Requires minimal maintenance (felt lubrication, monthly inspection, and cleaning).

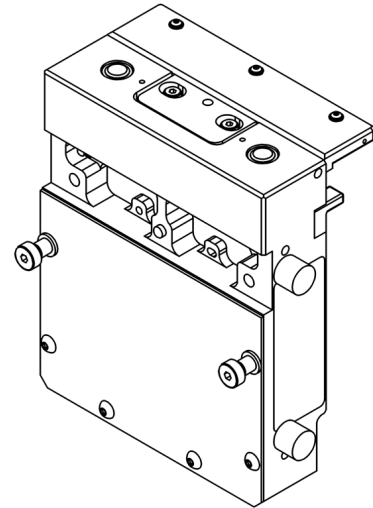

### Part Numbers

Part	Part Number
2-Magnet pallet with IR tag	25193340
2-Magnet pallet without IR tag	25193342
3-Magnet pallet with IR tag	25193341
3-Magnet pallet without IR tag	25193343
IR tag (accessory)	SP-1061122

**Dimensions**

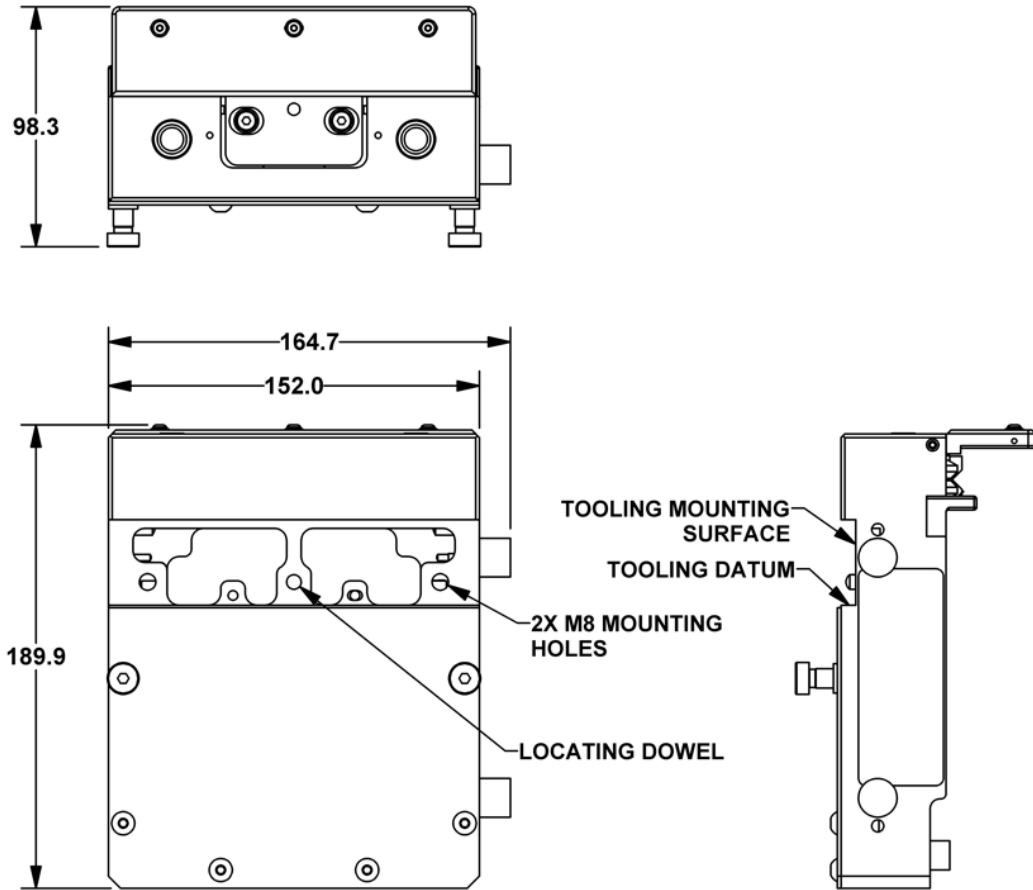

***Dimensions for reference only. See SuperTrak Design Package for detailed drawings.***

### Typical Pallet Wheel Lifespan

Pallet Wheel	Distance <sup>a</sup>	Velocity	Rating
Upper v-wheels with rail lubrication	50,000 km (31,068 mi)	Up to 4 m/sec (13.1 ft/sec)	<0.050 mm (<0.0019 in.) wear from radius See <i>Flat Wheel Nominal Dimensions</i> on page 304, and <i>V-Wheel Nominal Dimensions</i> on page 304 for additional information.
Lower flat wheels	25,000 km (15,534 mi)		

a. Assumes correct alignment. Lifespan improves when the system is correctly aligned and installed in a clean environment.

### Flat Wheel Nominal Dimensions

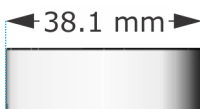

### V-Wheel Nominal Dimensions

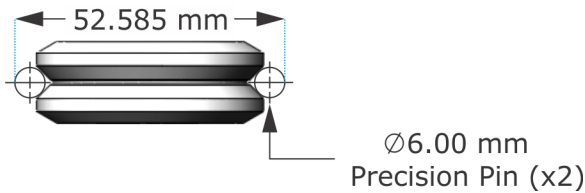

### Technical Specifications

Specification	Applicable For	Value	
		2-Magnet Assembly	3-Magnet Assembly
Accelerating force of motor (max.) <sup>a</sup>	Straight section	120 N (26.97 lbf)	160 N (35.96 lbf)
	180 deg. section 500 mm (19.68 in.)	60 N (13.48 lbf)	80 N (17.98 lbf)
	180 deg. section 800 mm (31.49 in.)	60N (13.48 lbf)	80 N (17.98 lbf)
	90 deg. section (31.49 in.)	60N (13.48 lbf)	80 N (17.98 lbf)

Specification	Applicable For	Value	
		2-Magnet Assembly	3-Magnet Assembly
Acceleration (max.) <sup>a</sup>	1 kg (2.20lb) payload	40 m/s <sup>2</sup> (131.2 ft./s <sup>2</sup> ) See <a href="#">Pallet Linear Acceleration Vs. Payload</a> on page 308.	
	10 kg (22.05 lb) payload	10 m/s <sup>2</sup> (32.8 ft./s <sup>2</sup> ) See <a href="#">Pallet Linear Acceleration Vs. Payload</a> on page 308.	
Input power (for planning purposes) <sup>b</sup>	Pallets	275W	
Magnetic field strength	Pallets	2.5 to 268.0 Gs See <a href="#">2-Magnet Pallet Magnetic Measurement Values</a> on page 311, and <a href="#">Pallet Magnet Recommendations</a> on page 309	3.0 to 1400.0 Gs See <a href="#">3-Magnet Pallet Magnetic Measurement Values</a> on page 312, and <a href="#">Pallet Magnet Recommendations</a> on page 309.
Magnetic force	Straight section	860 N (193.34 lbf)	1290 N (290.00 lbf)
	180 deg. section 500 mm (19.68 in.)	430 N (96.67 lbf)	645 N (145.00 lbf)
	180 deg. section 800 mm (31.49 in.)	590 N (132.64 lbf)	775 N (174.23.00 lbf)
Material	Pallets	<ul style="list-style-type: none"> <li>• Cover - thermoplastic film Lubricating</li> <li>• Lubrication felt - SAE F1</li> <li>• Magnets - neodymium</li> <li>• Guide roller - polyoxymethylene (POM)</li> <li>• Bumper - chloroprene rubber (CR)</li> <li>• Keeper plate - polycarbonate (PC) and steel</li> <li>• Base plate - aluminum; anodized</li> </ul>	
Maximum unsupported process torque perpendicular to pallet motion <sup>c</sup>	Pallets	30 N-m (22.13 ft.-lbf)	50 N-m (36.88 ft.-lbf)
Maximum application force applied to a single pallet wheel in any direction	Pallets	150 N (33.7 lbf)	

Specification	Applicable For	Value	
		2-Magnet Assembly	3-Magnet Assembly
Minimum pitch from center-to-center of two (2) pallets (as measured along the flat rail)	Straight section (with bumpers)	167 mm (6.57 in.)	200 mm (7.87 in.)
	Straight section (without bumpers)	154 mm (6.06 in.)	200 mm (7.87 in.)
	180 deg (500 mm) section	175 mm (6.89 in.)	200 mm (7.87 in.)
	180 deg (800 mm) section	163 mm (6.42 in.)	200 mm (7.87 in.)
	90 deg. section	163 mm (6.42 in.)	200 mm (7.87 in.)
Payload	Pallets	See <a href="#">Pallet Linear Acceleration Vs. Payload</a> on page 308, <a href="#">Pallet Linear Acceleration Vs. Payload</a> on page 308, and <a href="#">Pallet Magnet Recommendations</a> on page 309.	
Repeatability <sup>a</sup>	Straight section (X-axis)	±0.01 mm (±0.00039 in.)	
	Straight section (Y-axis)	±0.015 mm (±0.00059 in.)	
	Straight section (Z-axis)	±0.025 mm (±0.00098 in.)	
	Curved sections (X, Y, and Z-axis)	±0.025 mm (±0.00098 in.)	
Speed (max.) <sup>a</sup>	Straight section	4 m/s (13.1 ft./s)	
	Curved section	4 m/s (13.1 ft./s)	
Maximum tilting angle <sup>d</sup>	Pallets	0.377°	

Specification	Applicable For	Value	
		2-Magnet Assembly	3-Magnet Assembly
Weight (without keeper plate)	Pallets	2.02 kg (4.45 lbs)	2.4 kg (5.29 lbs)
Weight (with keeper plate)	Pallets	2.2 kg (1.85 lbs)	2.7 kg (5.95 lbs)

a. Values depend on the application. Repeatability axes for straight sections are defined in the graphic below.

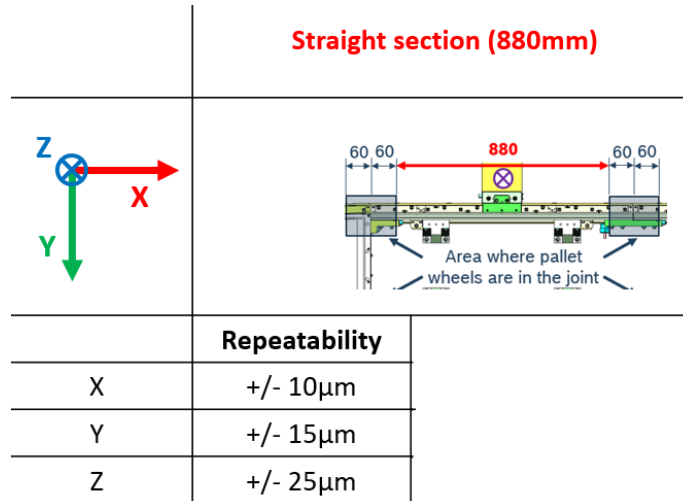

- b. Validation of power consumption to be done with a TrakMaster simulation.
- c. Includes process force, product fixture mass, and product mass. The rotation point for the moment load is calculated from the flat wheels for downward forces (left image), and from the v-wheels for upward forces (right image).

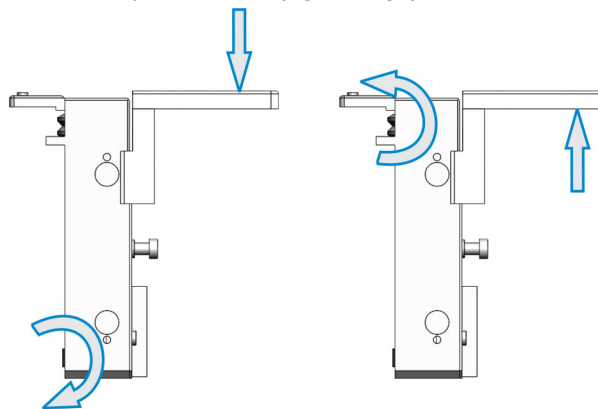

d. The system is designed to be operated with the v-wheels in full contact with the upper v-rail at all times. The anti-tip blocks provide additional support in the event of an unexpected application applied.

### Pallet Linear Acceleration Vs. Payload

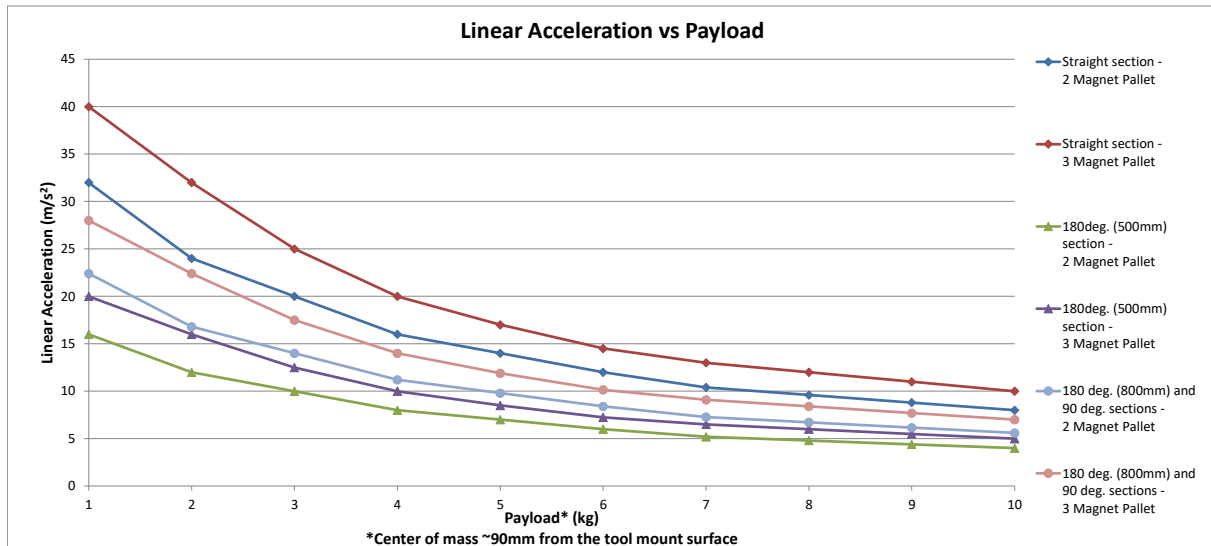

### Pallet Maximum Velocity Vs. Payload on a 180 deg. Section



On a 180 deg. section (500 mm) in a vertically mounted system (over/under configuration), the maximum velocity for a 3-magnet pallet with a 4 kg payload with CoM ~90 mm is ~2.2m/s.



Contact Automation Tooling Systems for data related to your system specifications.

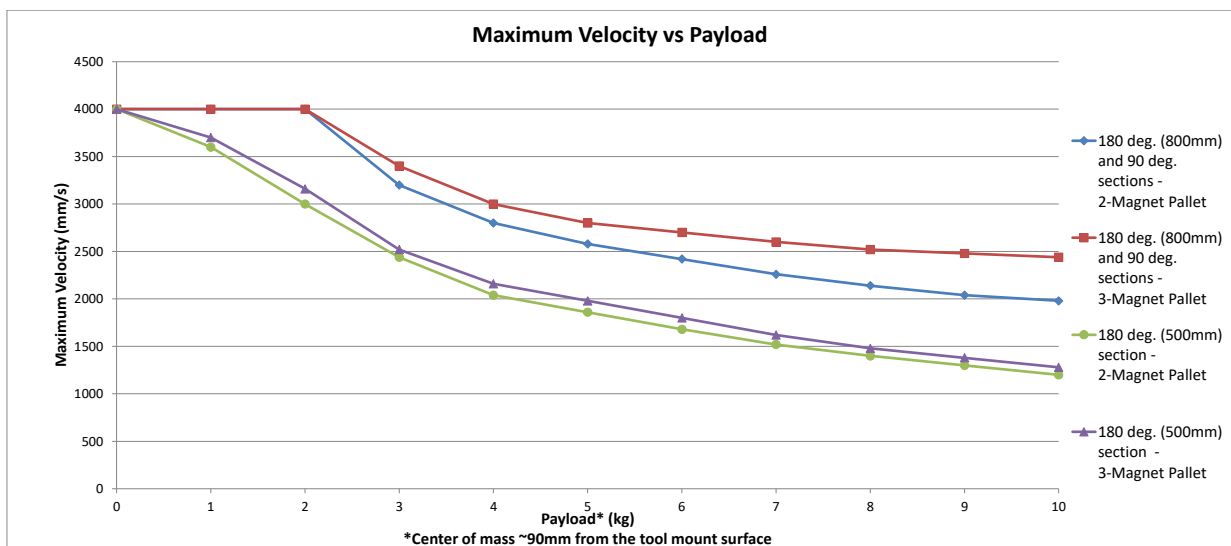



## Pallet Magnet Recommendations

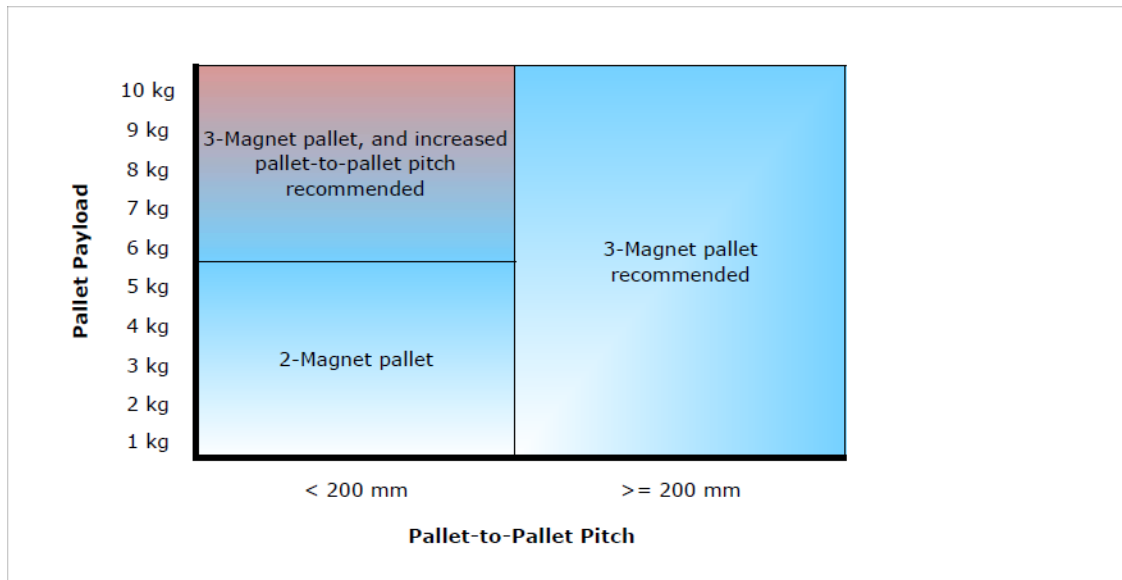

## Pallet Motion at a Constant Velocity



A 3\* standard deviation for following error is provided to show the +/- positioning tolerance of the pallet 99.7% of the time.

Component <sup>a</sup>	Constant Velocity (mm/s)	Laser Interferometer <sup>b</sup> (+/- microns)	SuperTrak Encoders <sup>b</sup> (+/- microns)
Pallet 2-magnet	20	31	23
	50	38	28
	100	48	32
	200	40	28
	500	69	25
	1000	63	35
Pallet 3-magnet	20	31	24
	50	35	27
	100	51	35
	200	49	35
	500	75	28
	1000	58	32

- a. Calculations for pallet motion predictability are based on the following test:
- A pallet is programmed to travel between the two (2) targets at various constant velocities (shown as Constant Velocity in the table).
  - The pallet motion is measured two (2) different ways: the SuperTrak encoders using the TrakMaster built-in Scope feature, and an external laser interferometer.
  - A target is placed at the 0 mm (0 in.) and 1000 mm (39.37 in.) position on a straight section.
- b. The laser interferometer and SuperTrak encoder results vary from section-to-section due to manufacturing tolerances.
- The following settings and hardware versions were used during this test:
- Control gains: P=8, I=0.4, D=4, FF=5, Moving Filter=0.5, Stationary Filter=0.5
  - Coil driver version: ACB3000-C02
  - Controller firmware version: 3.0.10.0 using the updated March 2019 force table.

**Pallet Magnetic Field Strength Measurement Locations**

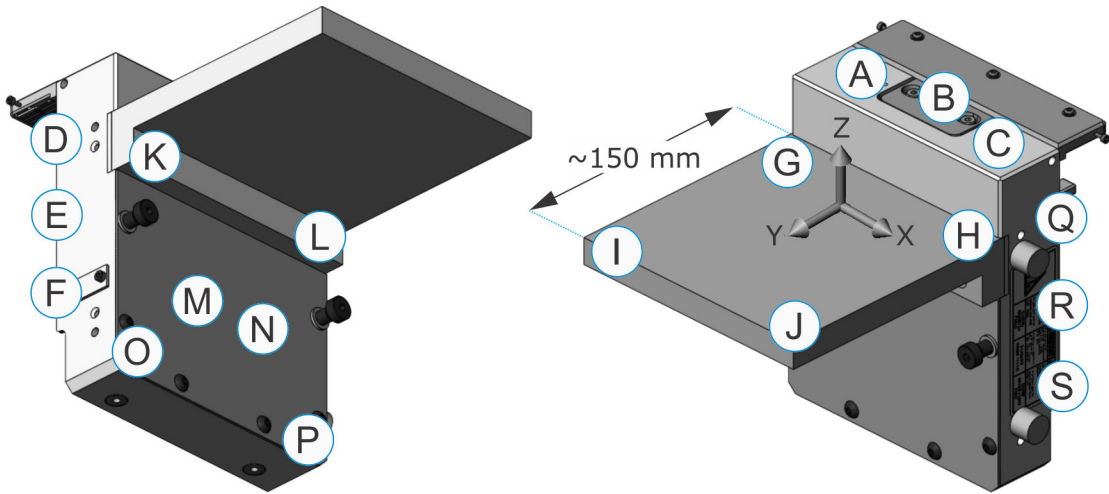

**2-Magnet Pallet Magnetic Measurement Values**

All measurements in the following table are in Gauss units.

See [Pallet Magnetic Field Strength Measurement Locations](#) on page 311 for the magnetic field strength measurement locations, and [Frame of Reference](#) on page 3 for a description of X, Y, and Z.

Location	2-Magnet Pallet Enabled at a Standstill			2-Magnet Pallet at Peak Force <sup>a</sup>		
	X	Y	Z	X	Y	Z
A	14	10	10	117	157	149
B	3	3.5	2.5	15	17	36
C	14	10	10	117	157	149
D	8	8	23	180	249	221
E	17	3	21	140	268	171
F	13	15	32	180	200	155
G	13	11	6	55	60	30
H	13	11	6	55	60	30
I	2.8	2.7	2.5	2.8	2.7	7
J	2.8	2.7	2.5	2.8	2.7	7
K	10	10	10	45	40	51
L	10	10	10	45	40	51

Location	2-Magnet Pallet Enabled at a Standstill			2-Magnet Pallet at Peak Force <sup>a</sup>		
	X	Y	Z	X	Y	Z
M	19	12	45	45	69	115
N	19	12	45	45	69	115
O	9	13	10	25	43	23
P	9	13	10	25	43	23
Q	8	8	23	180	249	221
R	17	3	21	140	268	171
S	13	15	32	180	200	155

a. Peak force measurements are captured when the coils are at maximum current. This electromagnetic field is a momentary field that could exist during acceleration at the maximum rate for a given payload.

### 3-Magnet Pallet Magnetic Measurement Values

All measurements in the following table are in Gauss units.

See [Pallet Magnetic Field Strength Measurement Locations](#) on page 311 for the magnetic field strength measurement locations, and [Frame of Reference](#) on page 3 for a description of X, Y, and Z.

Position	3-Magnet Pallet Enabled at Standstill			3-Magnet Pallet at Peak Force <sup>a</sup>		
	X	Y	Z	X	Y	Z
A	75	94	62	110	101	85
B	18	19	29	23	19	31
C	75	94	62	110	101	85
D	116	70	180	1210	270	606
E	250	38	280	1400	450	1135
F	64	65	90	260	96	100
G	40	50	19	43	53	24
H	40	50	19	43	53	24
I	5	4.5	5	5	4.5	6
J	5	4.5	5	5	4.5	6

Position	3-Magnet Pallet Enabled at Standstill			3-Magnet Pallet at Peak Force <sup>a</sup>		
	X	Y	Z	X	Y	Z
<b>K</b>	90	90	128	90	112	157
<b>L</b>	90	90	128	90	112	157
<b>M</b>	124	31	120	134	31	140
<b>N</b>	124	31	120	134	31	140
<b>O</b>	22	38	3	22	39	4
<b>P</b>	22	38	3	22	39	4
<b>Q</b>	116	70	180	1210	270	606
<b>R</b>	250	38	280	1400	450	1135
<b>S</b>	64	65	90	260	96	100

a. Peak force measurements are captured when the coils are at maximum current. This electromagnetic field is a momentary field that could exist during acceleration at the maximum rate for a given payload.

## Straight Section with FME Data Sheet

The straight section with front mounted electronics (FME) generates and regulates the electromagnetic field for the pallets.

### Features

- Bevels on the upper v-rail overlap at SuperTrak conveyance platform section transitions to provide a smooth, low-vibration transport surface for pallets.
- Includes:
  - Encoders for contact-free position tracking of pallets.
  - Three (3) 8 mm T-slots for mounting brackets, cable ducts, and other tooling.
  - Two (2) stands for stable mounting on a frame and smooth height adjustment.
  - Accessible electronics with door.
- Requires minimal maintenance (weekly cleaning of the flat wear strip).

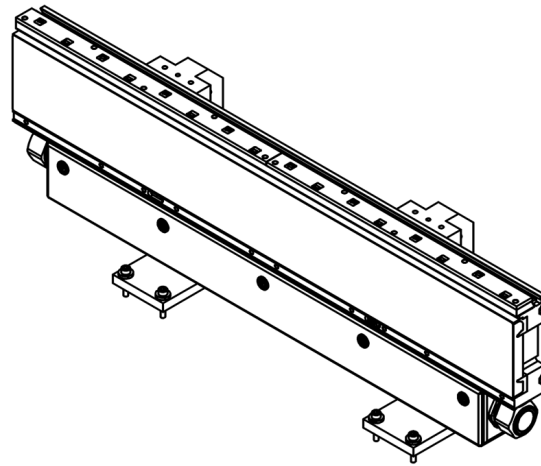

### Part Numbers

Part	Part Number
Straight section with front-mounted electronics (with stands)	1060391
Straight section with front-mounted electronics (without stands)	1060387-S

**Dimensions**

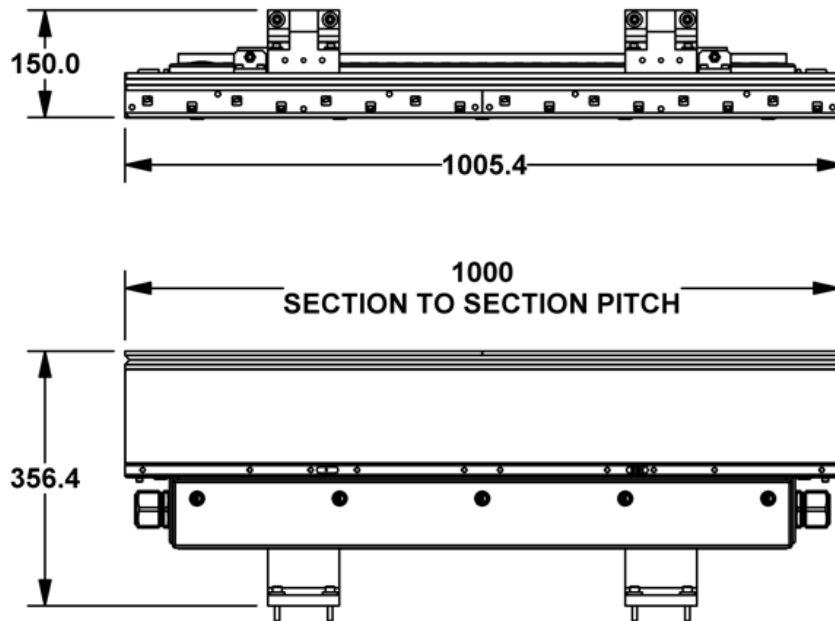

*Dimensions for reference only. See SuperTrak Design Package for detailed drawings.*

**Technical Specifications**

Specification	Value
24V digital bus FLA	250mA
Accelerating force (max.)	<ul style="list-style-type: none"> <li>• 120 N (with 2-magnet pallets)</li> <li>• 160 N (with 3-magnet pallets)</li> </ul>
Material	Aluminum anodized, stainless steel, polyamide (PA), polycarbonate (PC), epoxy resin.
Peak FLA (Amps) on 28VDC motor bus	100A
Voltage	<ul style="list-style-type: none"> <li>• 28 VDC (motor)</li> <li>• 24 VDC (digital)</li> </ul>
Weight	<ul style="list-style-type: none"> <li>• 40.8 kg (90 lbs) without stands</li> <li>• 50.8 kg (112 lbs) with stands</li> </ul>

## Straight Section with FME Certifications

Region	Certifications
North America	Certified to UL 61800-5-1:2017 PowerDrive Systems, UL508:2013 & CAN/CSA C22.2 No 14:2013 Industrial Control.
European Economic Area (CE markings)	EU- Declaration of Conformity per LVD 2014/35/EU: EN 61800-5-1:2017 Power Drive Systems & EN 619:2010 Continuous Handling Equipment 2014/30/EU – Electromagnetic Compatibility: EN 61000-6-2:2005 Immunity, EN 61000-6-4:2011 Emissions

*For detailed information on SuperTrak component certifications, visit <https://supertrakconveyance.com/certifications/>*



## Straight Section with RME Data Sheet

The straight section with rear mounted electronics (RME) generates and regulates the electromagnetic field for the pallets.

### Features

- Bevels on the upper v-rail overlap at SuperTrak conveyance platform section transitions to provide a smooth, low-vibration transport surface for pallets.
- Access to the electronics from the front is not required, since the electronics are mounted in the rear.
- Low-profile stands allow for a low profile installation.
- Includes:
  - Encoders for contact-free position tracking of pallets.
  - Eight (8) slots for mounting brackets, cable ducts, and other tooling.
  - Two (2) stands for stable mounting on a frame and smooth height adjustment.
  - Rear mounted electronics, to allow for a horizontal or vertical (also known as over/under) installation.
- Options include:
  - Standard-height stands
  - Low-profile stands
- Requires minimal maintenance (weekly cleaning of the flat wear strip).

Straight section RME with standard-height stands

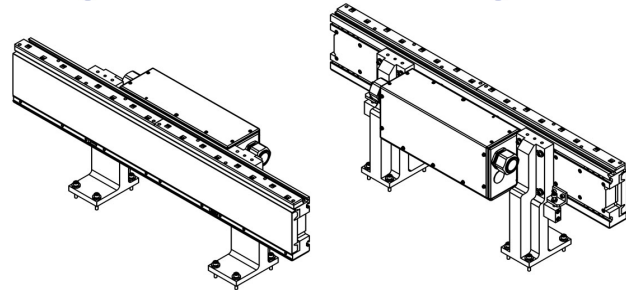

Straight section RME with low-profile stands

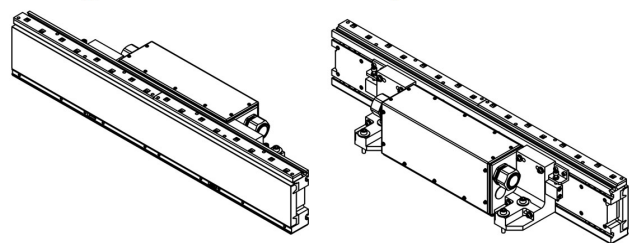

### Part Numbers

Part	Part Number
Straight section with rear-mounted electronics and low-profile stand	125414648
Straight section with rear-mounted electronics and standard-height stand	125780473

**Dimensions**

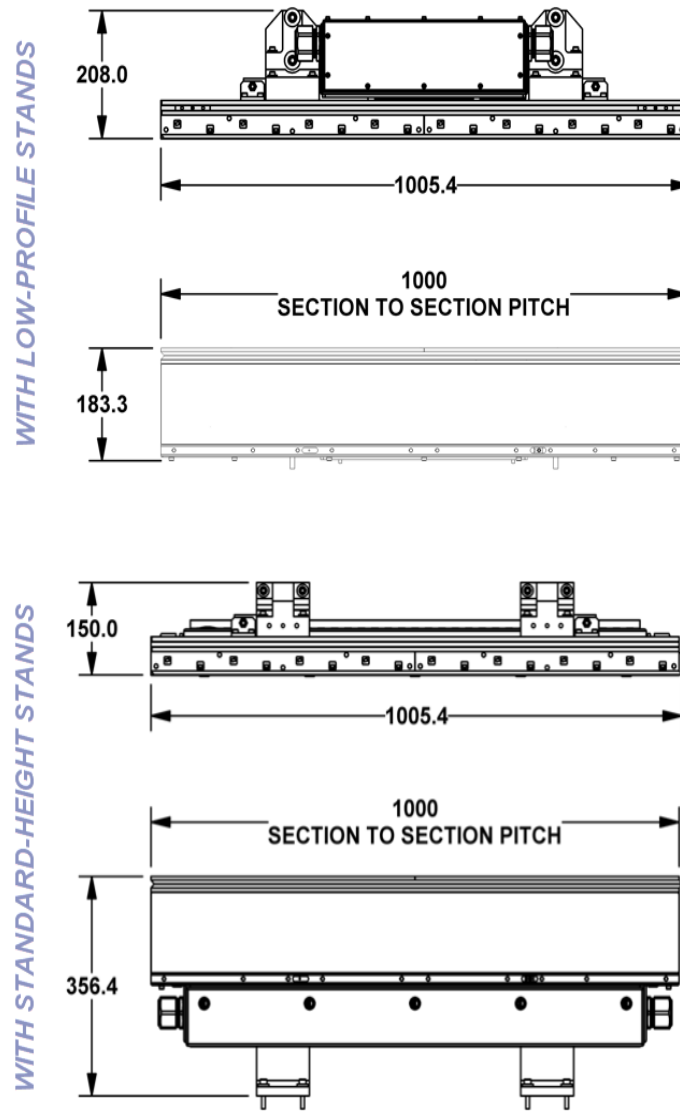

*Dimensions for reference only. See SuperTrak Design Package for detailed drawings.*

## Technical Specifications

Specification	Value
24V digital bus FLA	250mA
Accelerating force (max.)	<ul style="list-style-type: none"> <li>• 120 N (with 2-magnet pallets)</li> <li>• 160 N (with 3-magnet pallets)</li> </ul>
Material	Aluminum anodized, stainless steel, polyamide (PA), polycarbonate (PC), epoxy resin.
Peak FLA (Amps) on 28VDC motor bus	100A
Voltage	<ul style="list-style-type: none"> <li>• 28 VDC (motor)</li> <li>• 24 VDC (digital)</li> </ul>
Weight	<ul style="list-style-type: none"> <li>• 41 kg (90.4 lbs) without stands</li> <li>• 52 kg (114.6 lbs) with low-profile stands</li> <li>• 57 kg (125.7 lbs) with standard-height stands</li> </ul>

## Straight Section with RME Certifications

Region	Certifications
North America	Certified to UL 61800-5-1:2017 PowerDrive Systems, UL508:2013 & CAN/CSA C22.2 No 14:2013 Industrial Control.
European Economic Area (CE markings)	EU- Declaration of Conformity per LVD 2014/35/EU: EN 61800-5-1:2017 Power Drive Systems & EN 619:2010 Continuous Handling Equipment 2014/30/EU – Electromagnetic Compatibility: EN 61000-6-2:2005 Immunity, EN 61000-6-4:2011 Emissions

*For detailed information on SuperTrak component certifications, visit <https://supertrakconveyance.com/certifications/>*

## 180 Deg. Section (500 mm) with Standard-Height Stands Data Sheet

The 180 deg. section with standard-height stands generates and regulates the electromagnetic field for the pallets.

### Features

- Bevelling on the upper v-rail overlap at SuperTrak conveyance platform section transitions to provide a smooth, low-vibration transport surface for pallets.
- Mountable in an upright orientation.
- Includes:
  - Encoders for contact-free position tracking of pallets.
  - Access hole for power supply cable.
  - Three (3) stands for stable mounting on a frame, and smooth height adjustment.
  - Accessible electronic box by removing a cover.
- Requires minimal maintenance (weekly cleaning of the flat wear strip).

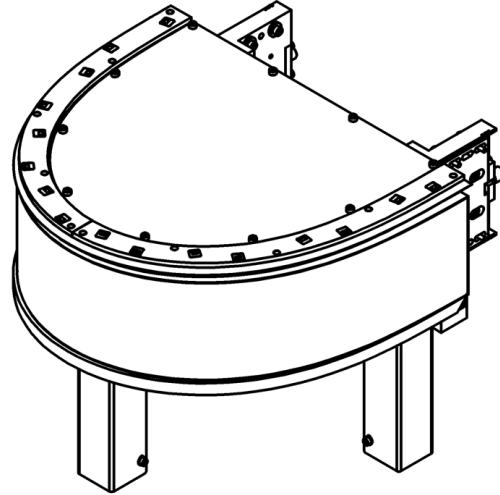

### Part Number

Part	Part Number
180 deg. section with standard-height stands	1060638

## Dimensions

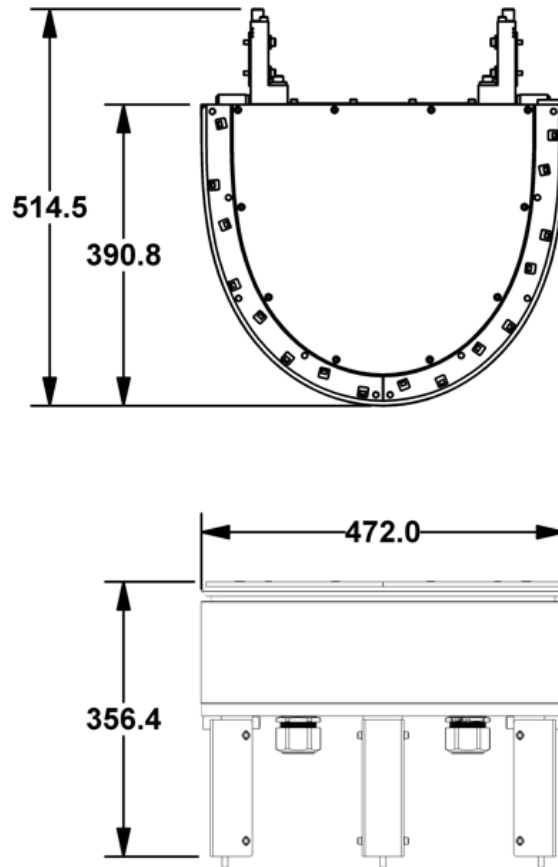

**Dimensions for reference only. See SuperTrak Design Package for detailed drawings.**

## Technical Specifications

Specification	Value
24V digital bus FLA	500mA
Acceleration	See <a href="#">Pallet Linear Acceleration Vs. Payload</a> on page 308.
Material	Aluminum anodized, stainless steel, polyamide (PA), polycarbonate (PC), epoxy resin.
Voltage	<ul style="list-style-type: none"> <li>• 28VDC (motor)</li> <li>• 24VDC (digital)</li> </ul>
Peak FLA (Amps) on 28VDC motor bus	150A
Weight	65 kg (143.3 lbs)

### 180 Deg. (500 mm) Section Certifications

Region	Certifications
North America	Certified to UL 61800-5-1:2017 PowerDrive Systems, UL508:2013 & CAN/CSA C22.2 No 14:2013 Industrial Control.
European Economic Area (CE markings)	EU- Declaration of Conformity per LVD 2014/35/EU: EN 61800-5-1:2017 Power Drive Systems & EN 619:2010 Continuous Handling Equipment 2014/30/EU – Electromagnetic Compatibility: EN 61000-6-2:2005 Immunity, EN 61000-6-4:2011 Emissions

*For detailed information on SuperTrak component certifications, visit <https://supertrakconveyance.com/certifications/>*

## 180 Deg. Section (500 mm) with Low-Profile Stands Data Sheet

The 180 deg. section with low-profile stands generates and regulates the electromagnetic field for the pallets.

### Features

- Bevelling on the upper v-rail overlap at SuperTrak conveyance platform section transitions to provide a smooth, low-vibration transport surface for pallets.
- Mountable in an upright, or vertical over/under orientation.
- Includes:
  - Encoders for contact-free position tracking of pallets.
  - Access hole for power supply cable access.
  - Accessible electronic box by removing a cover.
- Requires minimal maintenance (weekly cleaning of the flat wear strip).

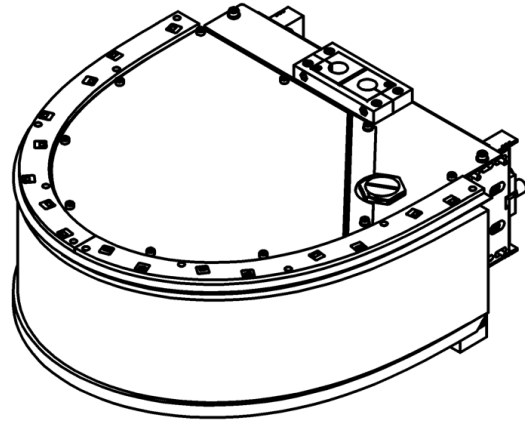

### Part Number

Part	Part Number
180 deg. section with low-profile stands	125420930

### Dimensions

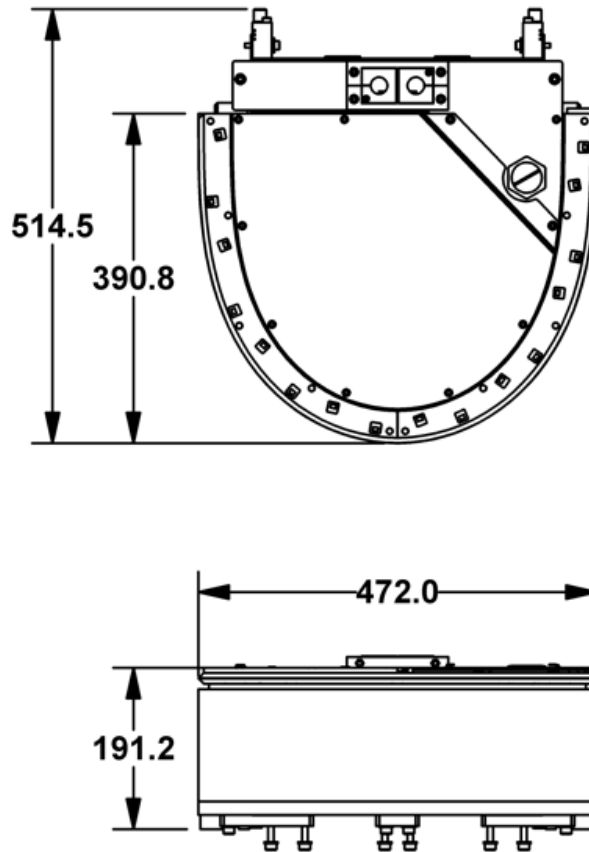

*Dimensions for reference only. See SuperTrak Design Package for detailed drawings.*

### Technical Specifications

Specification	Value
24V digital bus FLA	500mA
Acceleration	See <a href="#">Pallet Linear Acceleration Vs. Payload</a> on page 308.
Material	Aluminum anodized, stainless steel, polyamide (PA), polycarbonate (PC), epoxy resin.
Peak FLA (Amps) on 28VDC motor bus	150A
Voltage	<ul style="list-style-type: none"> <li>• 28VDC (motor)</li> <li>• 24VDC (digital)</li> </ul>
Weight	64 kg (141.1 lbs)



### 180 Deg. (500 mm) Section Certifications

Region	Certifications
North America	Certified to UL 61800-5-1:2017 PowerDrive Systems, UL508:2013 & CAN/CSA C22.2 No 14:2013 Industrial Control.
European Economic Area (CE markings)	EU- Declaration of Conformity per LVD 2014/35/EU: EN 61800-5-1:2017 Power Drive Systems & EN 619:2010 Continuous Handling Equipment 2014/30/EU – Electromagnetic Compatibility: EN 61000-6-2:2005 Immunity, EN 61000-6-4:2011 Emissions

*For detailed information on SuperTrak component certifications, visit <https://supertrakconveyance.com/certifications/>*

## 180 Deg. Section (800 mm)

The 180 deg. section (800 mm) generates and regulates the electromagnetic field for the pallets.

### Features

- Bevels on the upper v-rail overlap at SuperTrak conveyance platform section transitions to provide a smooth, low-vibration transport surface for pallets.
- Includes:
  - Encoders for contact-free position tracking of pallets.
  - Access hole for power supply cable access.
  - Three (3) stands for stable mounting on a frame, and smooth height adjustment.
  - Accessible electronic box by removing a cover.
- Requires minimal maintenance (weekly cleaning of the flat wear strip).

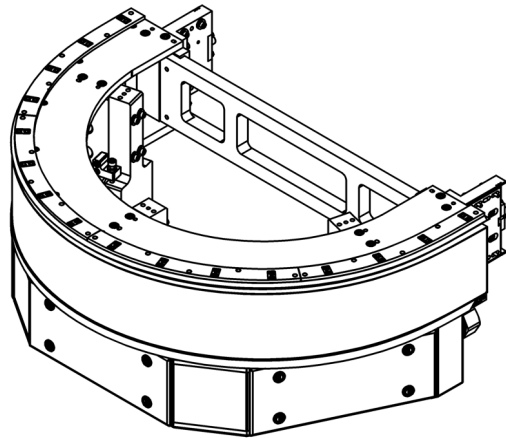

### Part Number

Part	Part Number
180 deg. section	25232698

**Dimensions**

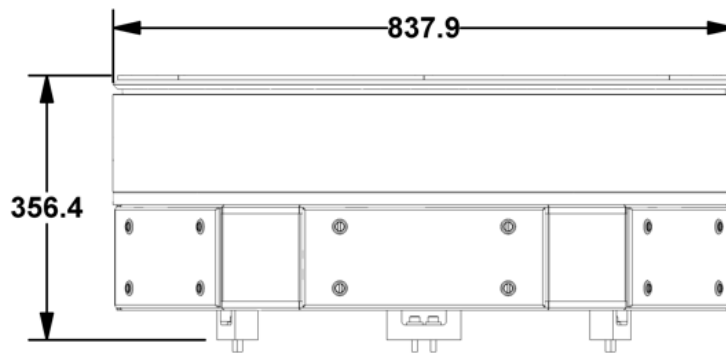
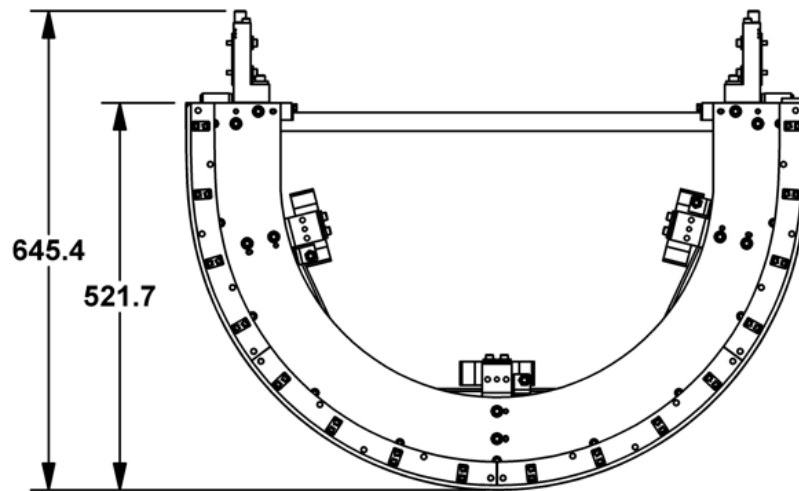

***Dimensions for reference only. See SuperTrak Design Package for detailed drawings.***

NOTE: If desired, the shipping brace (indicated in graphic at right) can be removed from the section after final installation.

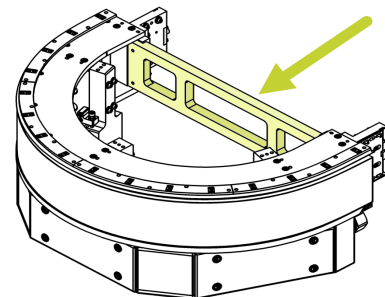

## Technical Specifications

Specification	Value
24V digital bus FLA	500mA
Acceleration	See <i>Pallet Linear Acceleration Vs. Payload</i> on page 308.
Material	Aluminum anodized, stainless steel, polyamide (PA), polycarbonate (PC), epoxy resin.
Peak FLA (Amps) on 28VDC motor bus	150A
Voltage	<ul style="list-style-type: none"> <li>• 28VDC (motor)</li> <li>• 24VDC (digital)</li> </ul>
Weight	109.8 kg (242 lbs)

## 180 Deg. (800 mm) Section Certifications

Region	Certifications
North America	Certified to UL 61800-5-1:2017 PowerDrive Systems, UL508:2013 & CAN/CSA C22.2 No 14:2013 Industrial Control.
European Economic Area (CE markings)	EU- Declaration of Conformity per LVD 2014/35/EU: EN 61800-5-1:2017 Power Drive Systems & EN 619:2010 Continuous Handling Equipment 2014/30/EU – Electromagnetic Compatibility: EN 61000-6-2:2005 Immunity, EN 61000-6-4:2011 Emissions

For detailed information on SuperTrak component certifications, visit <https://supertrakconveyance.com/certifications/>

## 90 Deg. Section

The 90 deg. section generates and regulates the electromagnetic field for the pallets.

### Features

- Bevelling on the upper v-rail overlap at SuperTrak conveyance platform section transitions to provide a smooth, low-vibration transport surface for pallets.
- Includes:
  - Encoders for contact-free position tracking of pallets.
  - Access hole for power supply cable access.
  - Three (3) stands for stable mounting on a frame, and smooth height adjustment.
  - Accessible electronic box by removing covers.
- Requires minimal maintenance (weekly cleaning of the flat wear strip).

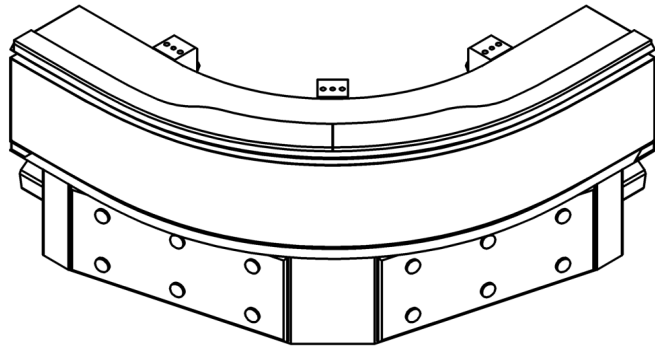

### Part Number

Part	Part Number
90 deg. section	125426817

### Dimensions

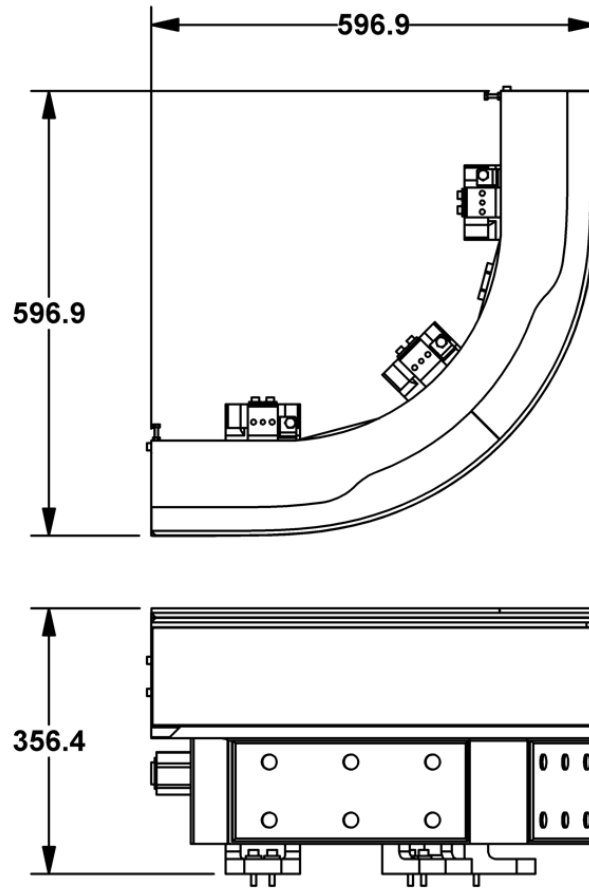

**Dimensions for reference only. See SuperTrak Design Package for detailed drawings.**

### Technical Specifications

Specification	Value
24V digital bus FLA	250mA
Acceleration	See <a href="#">Pallet Linear Acceleration Vs. Payload</a> on page 308.
Material	Aluminum anodized, stainless steel, polyamide (PA), polycarbonate (PC), epoxy resin.
Peak FLA (Amps) on 28VDC motor bus	100A
Voltage	<ul style="list-style-type: none"> <li>• 28VDC (motor)</li> <li>• 24VDC (digital)</li> </ul>
Weight	82 kg (182 lbs)

## 90 Deg. Section Certifications

Region	Certifications
North America	Certified to UL 61800-5-1:2017 PowerDrive Systems, UL508:2013 & CAN/CSA C22.2 No 14:2013 Industrial Control.
European Economic Area (CE markings)	EU- Declaration of Conformity per LVD 2014/35/EU: EN 61800-5-1:2017 Power Drive Systems & EN 619:2010 Continuous Handling Equipment 2014/30/EU – Electromagnetic Compatibility: EN 61000-6-2:2005 Immunity, EN 61000-6-4:2011 Emissions

*For detailed information on SuperTrak component certifications, visit <https://supertrakconveyance.com/certifications/>*

## Control Panel Data Sheet

The control panel provides controls for monitoring individual modules and pallets.

### Features

- Integration with the automation system safety circuit utilizes dual channel input with a feedback loop via provided terminals.
- Available in two (2) options:
  - 400Y230 VAC
  - 208Y120 VAC
- Includes:
  - An uninterruptible power supply (UPS).
  - Two (2) air filters.
  - An open interface to programmable logic controller (PLC): PROFINET, EtherNet/IP, EtherCAT, or PowerLink.

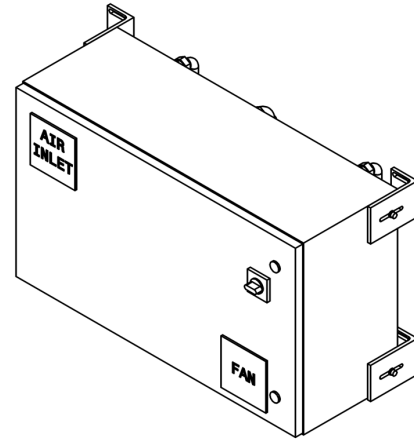

### Part Number

The control panel part number is configurable; it consists of five parts:

[A-Base Panel]-[B-Breaker Kit]-[C-Communication]-[D-PC]-[P5-Expansion]

The following table provides the values for each of the five parts:

Part Number	Part	Description	Code
A - Base Panel		Base panel code	25202161
B - Breaker Kit		208Y120VAC	NA
		400Y230VAC	EU
C - Communication		PROFINET	PR
		EtherNet/IP	EI
		EtherCAT	EC
		PowerLink	N
D - PC		Standard celeron-based controller	C
		Upgraded i5-based controller	I5
		Standard i3 controller	I3
P5 - Expansion		Expansion	E6

For example, 25202161-EU-PR-C-E6, and 25202161-NA-EI-I5-E6



**Dimensions**

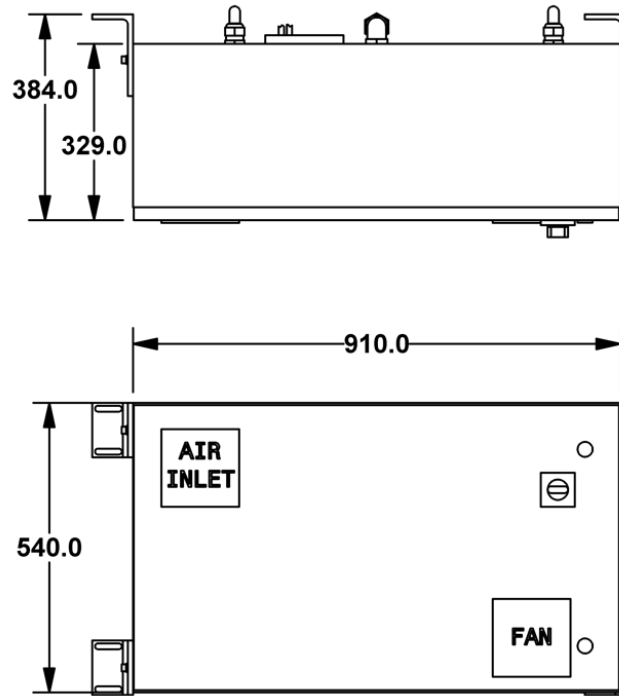

*Dimensions for reference only. See SuperTrak Design Package for detailed drawings.*

## Technical Specifications

Specification	Value	
	EU	NA
Control voltage	<ul style="list-style-type: none"> <li>• 24VDC (digital power supplied from the control panel)</li> <li>• 28VDC (motor power supplied from the power supplies)</li> </ul>	
Frequency	50/60 Hz	
Full load amps	36A	
Largest load	20A	
Line voltage	400Y230VAC+PE	208Y120VAC+PE
Materials	Steel sheet, lacquered, RAL7024, polyamide (PA)	
Phases	3 ph, 5-wire	
Short circuit current rating	5kA	
UPS current rating	15A	
UPS frequency	50/60 Hz	
UPS line voltage	24VDC	
Weight	70 kg (154.3 lbs)	

## Control Panel Certifications

Region	Certifications*
North America	Certified to UL 508A:2014 Industrial Control Panels.
European Economic Area (CE markings)	EU- Declaration of Conformity per LVD 2014/35/EU: EN 60204-1 Electrical Equipment of Machines 2014/30/EU – Electromagnetic Compatibility: EN 61000-6-2:2005 Immunity, EN 61000-6-4:2011 Emissions

\* Certifications for the control panel apply to part number 25202161 only. For detailed information on SuperTrak component certifications, visit <https://supertrakconveyance.com/certifications/>

## Power Supply Data Sheet

The power supply supplies power to straight and curved sections.

### Features

- Provides a modular power system; adjust the number of SuperTrak conveyance platform power supplies based on the size and requirements of the system.
- Includes:
  - A 28VDC power output cable.
  - An AC power input plug.
  - One (1) air filter.
  - Connection cable for PLC monitoring (24V).
  - One (1) mounting plate and screws.
  - Four (4) mounting brackets.

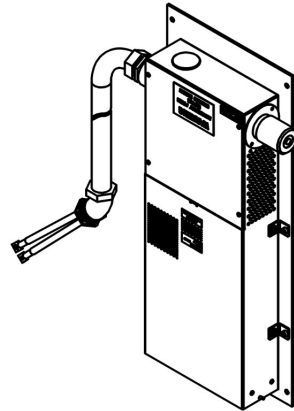

With back plate

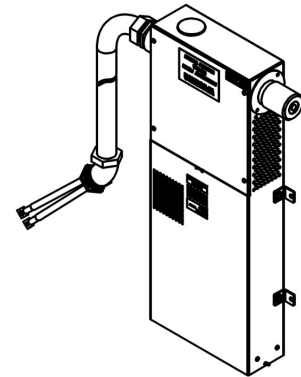

Without back plate

### Part Numbers

Part	Part Number
Power supply (with a mounting plate)	25195828
Power supply (without a mounting plate)	25270337

Dimensions (with back plate)

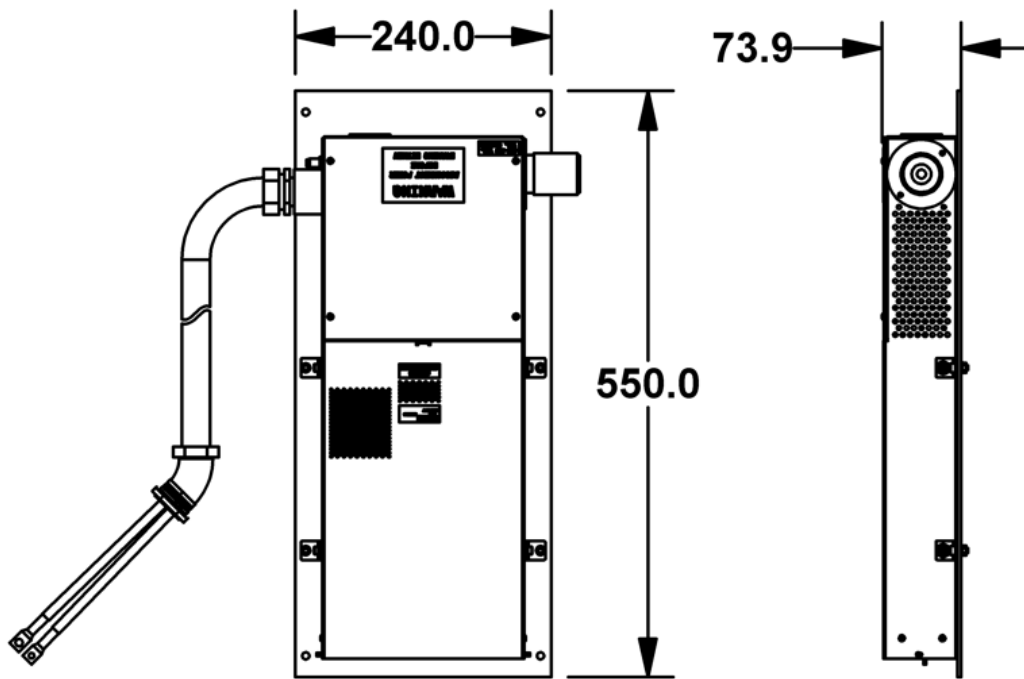

*Dimensions for reference only. See SuperTrak Design Package for detailed drawings.*

**Dimensions (without back plate)**

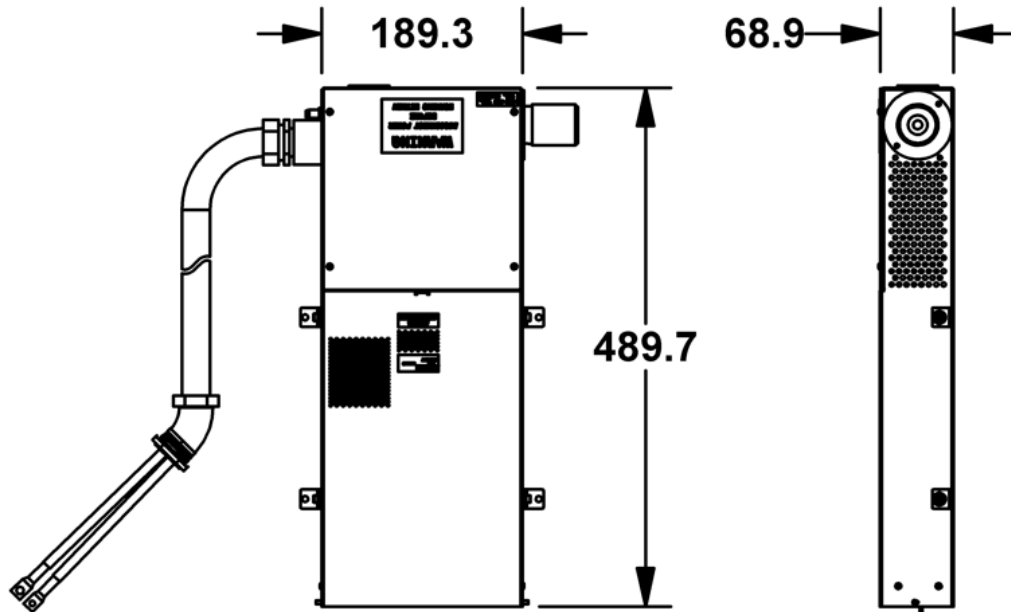

***Dimensions for reference only. See SuperTrak Design Package for detailed drawings.***

**Technical Specifications**

Specification	Value
Cable length	1500 mm (59.05 in.)
Class	IP20
Frequency	50/60Hz
Main voltage (input)	200-240VAC
Efficiency (%)	85% (typical)
Material	Aluminum, brass, nickel-plated, polyamide (PA), PUR
Max. number of power supplies	Application-dependent
Output wattage (continuous)	1500W
Output voltage	28VDC
Power supply with mounting plate	9 kg (20 lbs)
SCCR	5kA

## Power Supply Certifications

Region	Certifications*
North America	Certified to UL 61010-1:2018, CAN/CSAC22.2 No. 61010-1:2018 & UL 508:2013 Industrial Control.
European Economic Area (CE markings)	EU- Declaration of Conformity per LVD 2014/35/EU: EN 61010:2010 Safety Electrical Equipment for Measurement, Control. 2014/30/EU – Electromagnetic Compatibility: EN 61000-6-2:2005 Immunity, EN 61000-6-4:2011 Emissions

\* Certifications for the power supply apply to part number 25270337 (and 25270337-XX where XX represents alternate DC cable length) only. For detailed information on SuperTrak component certifications, visit <https://supertrakconveyance.com/certifications/>

## IR Reader Components (Optional) Data Sheet

The infrared (IR) components are optional. The IR reader mount assembly allows for easy installation of the IR reader on a SuperTrak conveyance platform. The IR tags assign a unique pallet ID to each pallet, and the IR reader reads the IR tag on the pallet.

### Features

- Simplifies SuperTrak conveyance platform recovery after a complete cold start.
- Provides data integrity when pallets are manually removed.
- Provides tracking of individual pallets.
- Allows pallet IDs to be read “on-the-fly”: pallets do not stop at the IR reader assembly.
- Batteries are not required. The assembly induces the necessary power into the tags for reading purposes.
- External PLC programming is not required. Integration of the IR reader assembly with the SuperTrak conveyance platform is plug-and-play.
- Options include:
  - IR tag (read-only)
  - IR reader
  - IR reader mount assembly

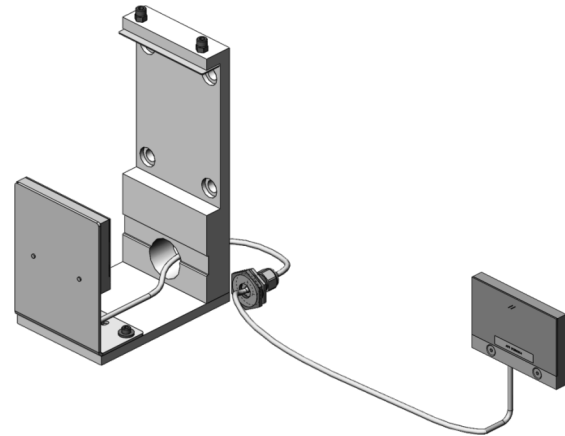

### Part Numbers

Part	Part Number
IR reader (no mount)	SP-25202314
IR reader mount assembly (with IR reader)	25202309
IR reader mount assembly (without IR reader)	SP-4727653
IR tag (read-only)	SP-1061122

### Dimensions

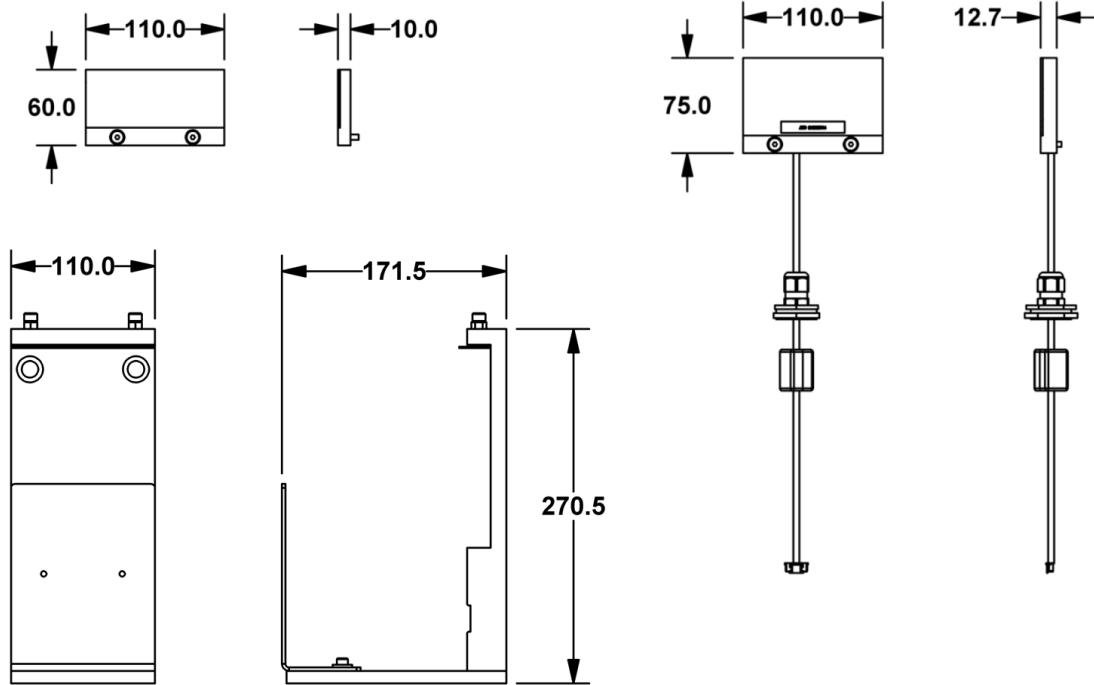

*Dimensions for reference only. See SuperTrak Design Package for detailed drawings.*

### Technical Specifications

Specification	Value		
	IR Tag	IR Reader Head	Assembly Mount
Laser		Class 1	
Mass	0.1 kg (0.2 lbs)	0.3 kg (0.7 lbs)	2.4 kg (5.3 lbs)
Material	Polyoxymethylene (POM)	polyoxymethylene (POM), brass, nickel-plated, PVC	Aluminum, anodized, steel



## Pallet Setup Tools (Optional) Data Sheet

The pallet setup tools are optional SuperTrak conveyance platform tools that allow you to align and calibrate pallet encoder strips.

### Features

- Provides easy alignment and calibration of pallet encoder strips.
- Includes the following tools:
  - Pallet setup stationary mount, which provides a fixed mounting surface for the pallet setup tools.
  - Pallet setup adjustable chip finder, which accurately positions a pallet setup stationary mount in relation to a defined encoder.
  - Pallet setup removable locate, which allows for adjustment of the pallet encoder strip assembly.

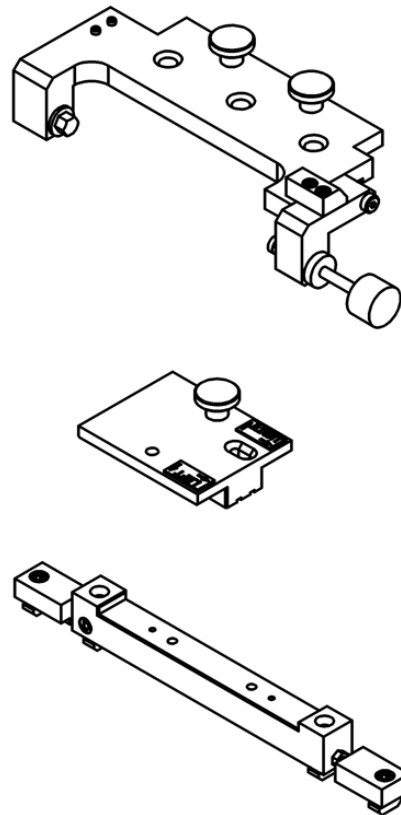

### Part Numbers

Part	Part Number
Pallet setup tools	4736082

### Dimensions

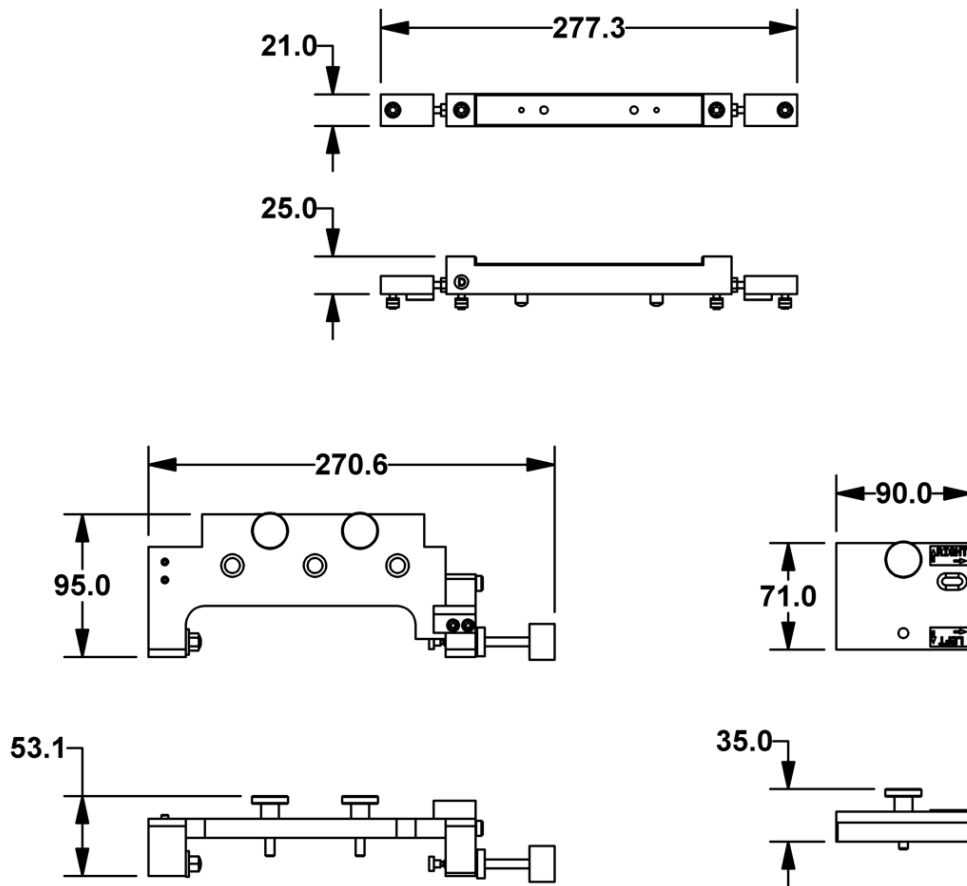

*Dimensions for reference only. See SuperTrak Design Package for detailed drawings.*

### Technical Specifications

Specification	Value
Mass	2.2 kg (4.9 lbs)
Material	Aluminum, steel

## Pallet Removal Tool (Optional) Data Sheet

The pallet removal tool allows for quick and easy removal of pallets from straight sections or 180 deg. sections.

### Features

- Provides leverage to easily overcome the magnetic forces of the pallets.
- Includes two locking latches to safely secure the pallet.

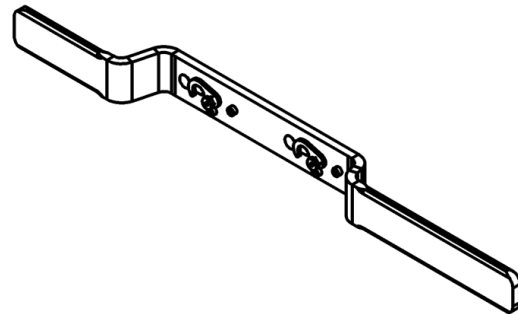

### Part Numbers

Part	Part Number
Pallet removal tool	25172729

### Dimensions

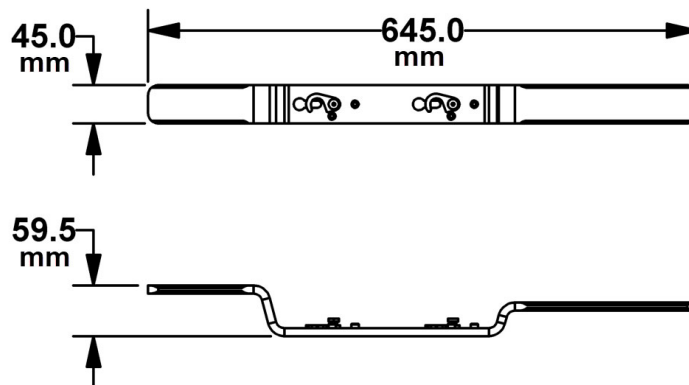

*Dimensions for reference only. See SuperTrak Design Package for detailed drawings.*

### Technical Specifications

Specification	Value
Material	Aluminum
Weight	0.8 kg (1.76 lbs)

## SuperTrak GEN3 Frames

The SuperTrak GEN3 frames provide a stable adjustable mounting foundation for straight sections and curved sections.

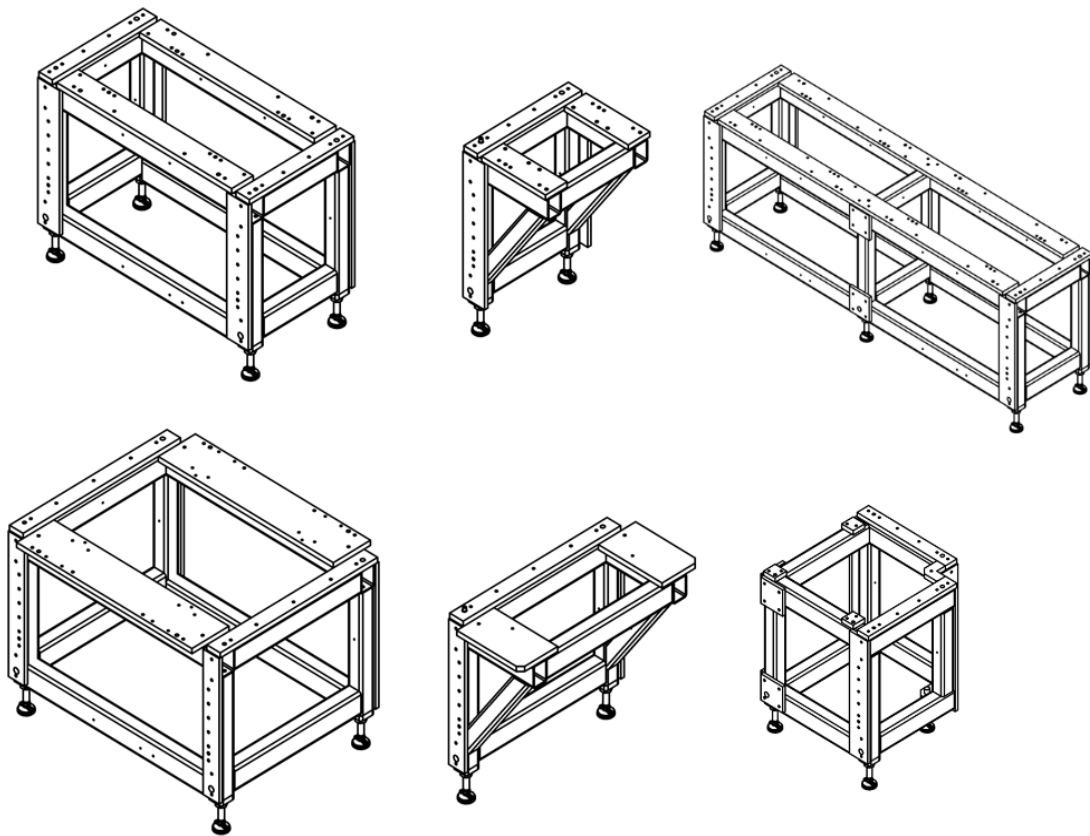

### Features

- Robust welded frame.
- Available in six formats to accommodate the different types and widths of track sections.
- Modular design
- Includes:
  - Adjustable leveling feet.
  - Threaded holes for attaching plates, cross-braces, side connection plates, and control panels.
  - Connection plate kits and section mounting kits

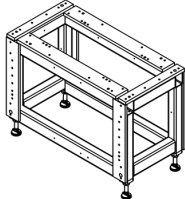
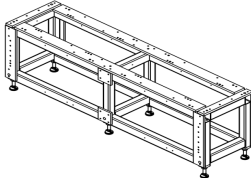
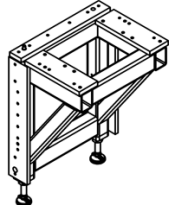
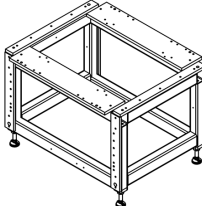
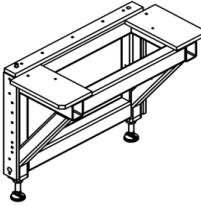
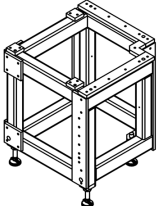

**Part Numbers**

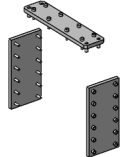
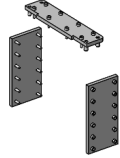
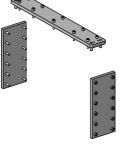
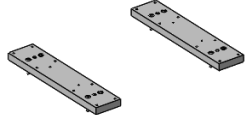
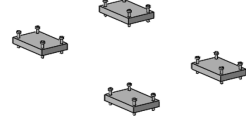
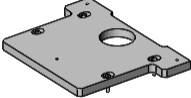
Part		Part Number
SuperTrak GEN3 Frame 500 x 1 m		125354246
SuperTrak GEN3 Frame 500 x 2 m		125767467
SuperTrak GEN3 Frame 500 Compact		125354247
SuperTrak GEN3 Frame 800 x 1 m		125721554
SuperTrak GEN3 Frame 800 Compact		700066211
SuperTrak GEN3 Frame 90 Deg.		125777464

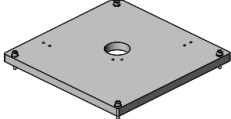
Part		Part Number
Middle Connection Kit (500)		125354248
End Connection Kit (500)		125354250
Middle Connection Kit (800)		125659677
Straight Section Mounting Kit (500)		125354251
Straight Section Mounting Kit (800)		25249251
Mounting Kit - 180 Deg. Section (500)		125354252
Mounting Kit - 180 Deg. Section (800)		125721562
Mounting Kit - 90 Deg. Section		700052303

All mounting kits include mounting hardware.

**Dimensions**

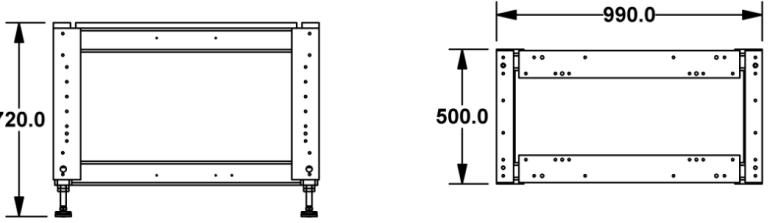
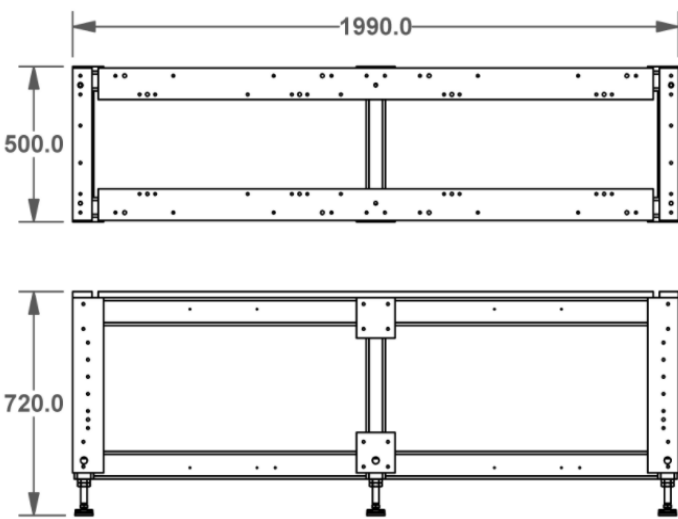
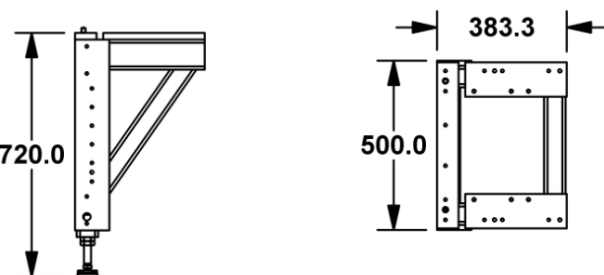
Frame Segment	Dimensions
<p>SuperTrak GEN3 Frame 500 x 1 m</p>	
<p>SuperTrak GEN3 Frame 500 x 2 m</p>	
<p>SuperTrak GEN3 Frame 500 Compact</p>	

Frame Segment	Dimensions	
SuperTrak GEN3 Frame 800 x 1 m		
SuperTrak GEN3 Frame 800 Compact		
SuperTrak GEN3 Frame 90 Deg.		

*Dimensions for reference only. See SuperTrak Design Package for detailed drawings.*

### Technical Specifications

	Value	
Specification	SuperTrak GEN3 frame - 1 m	SuperTrak GEN3 frame - 180 Deg. Mount
Mass	135 kg (297.6 lbs)	62 kg (136.7 lbs)
Material	Steel lacquered RAL7024, zinc die casting, steel, galvanized	



## Interconnect Kit (Straight Section to Straight Section)

The interconnect kit provides all the necessary hardware to physically connect two (2) adjacent straight sections with FME mechanically, electrically, and functionally.

### Features

The following items are included:

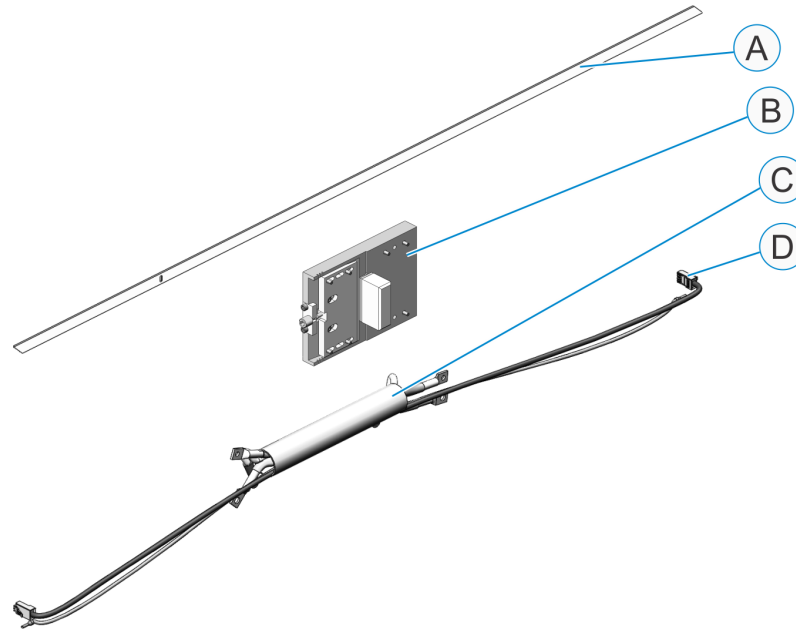

<b>A</b>	Flat rail	<b>C</b>	Straight-to-straight electrical interconnect
<b>B</b>	Wedge adjust	<b>D</b>	Ethernet network cable <sup>a</sup>

### Part Numbers

Part	Part Number
Ethernet network cable <sup>a</sup>	SP-3708400
Interconnect kit	4217881
Straight-to-straight electrical interconnect	SP-1060659
Wear strip	SP-1060669
Wedge adjust	SP-1060643

a. The Ethernet network cable is included with the straight-to-straight electrical interconnect, but is also offered separately because it may be damaged during assembly or maintenance.

## Interconnect (SuperTrak Control Panel to Curved Section)

The control panel to curved section interconnect provides the wires that are required between the curved section and the control panel.

See *Gateway Network Connections* on page 122.

### Features

The following items are included:

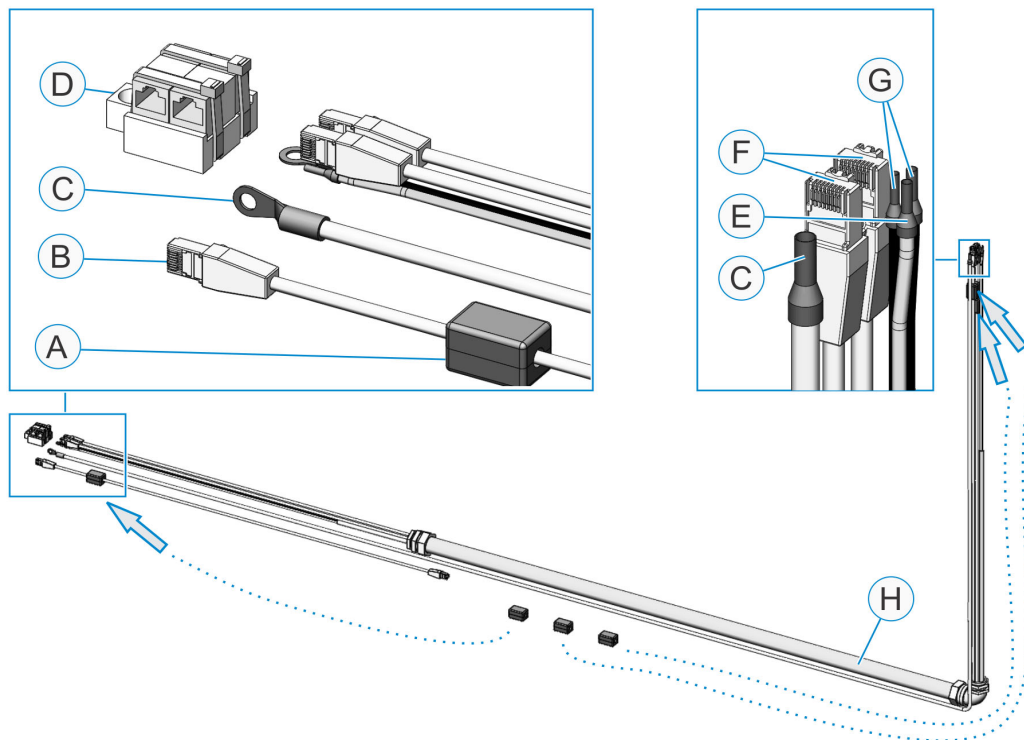

<b>A</b>	Ferrite (1 of 3)	<b>E</b>	Common connection
<b>B</b>	Left network patch cable	<b>F</b>	Two (2) 3 m <sup>a</sup> Ethernet cables - left and right network cables
<b>C</b>	3 m <sup>a</sup> ground cable <sup>b</sup>	<b>G</b>	24VDC digital power
<b>D</b>	F-F coupler (1 of 2)	<b>H</b>	1.2 m <sup>c</sup> Conduit

a. Optional length of 7.6 m.

b. The ground wire is 16mm<sup>2</sup>.

c. Optional lengths of 2 m, and 6.5 m.

## Part Numbers

Part	Part Number
1.2 m control panel to curved section interconnect	25240470
2 m control panel to curved section interconnect	125362696
6.5 m control panel to curved section interconnect	25221246

This page is intentionally blank.

# Appendix D: Unit Conversions

To Convert	Into	Multiply By
psi	kPa	6.8948
psi	bar	0.068947
psi	inHg	2.03602
kPa	psi	0.145038
kPa	bar	0.01
kPa	inHg	0.295301
bar	psi	14.503773773
bar	KPa	100.0
bar	inHg	29.5301
inHg	psi	0.491154
inHg	kPa	3.38638816
inHg	bar	0.03386388158
Gs	mT	0.1
cm	in.	0.3937
in.	cm	2.54
m	ft	3.2808
ft	m	0.3048

This page is intentionally blank.